

**DIGITAL**  
**CINEMA**

**AVAILABLE AT**  
**DIGITAL CINEMA**

**ARCAM | HDA**

---

**POWER AMPLIFIER**  
**AMPLIFICATEUR**  
**LEISTUNGSVERSTÄRKER**  
**EINDVERSTERKER**  
**AMPLIFICADOR DE POTENCIA**  
**УСИЛИТЕЛЬ МОЩНОСТИ**  
**AMPLIFICATORE DI POTENZA**  
**功率放大器**  
**파워 앰프**

---

**PA720 / PA240 / PA410**

**HANDBOOK**  
**MANUEL**  
**HANDBUCH**  
**HANDLEIDING**  
**MANUAL**  
**РУКОВОДСТВО**  
**MANUALE**  
**手冊**  
**핸드북**



# HANDBOOK

**ARCAM | HDA**

---

**POWER AMPLIFIER**

---

**PA720 / PA240 / PA410**

# Safety Guidelines

## Important Safety Instructions

1. Read these instructions.
2. Keep these instructions.
3. Heed all warnings.
4. Follow all instructions.
5. Do not use this apparatus near water.
6. Clean only with dry cloth.
7. Do not block any ventilation openings. Install in accordance with the manufacturer's instructions.
8. Do not install near any heat sources such as radiators, heat registers, stoves, or other apparatus (including amplifiers) that produce heat.
9. Do not defeat the safety purpose of the polarized or grounding-type plug.  
A polarized plug has two blades with one wider than the other. A grounding type plug has two blades and a third grounding prong. The wide blade or the third prong are provided for your safety. If the provided plug does not fit into your outlet, consult an electrician for replacement of the obsolete outlet.
10. Protect the power cord from being walked on or pinched particularly at plugs, convenience receptacles, and the point where they exit from the apparatus.
11. Only use attachments/accessories specified by the manufacturer.
12. Use only with the cart, stand, tripod, bracket, or table specified by the manufacturer, or sold with the apparatus.  
When a cart is used, use caution when moving the cart/apparatus combination to avoid injury from tip-over. 
13. Unplug this apparatus during lightning storms or when unused for long periods of time.

14. Refer all servicing to qualified service personnel.  
Servicing is required when the apparatus has been damaged in any way, such as power-supply cord or plug is damaged, liquid has been spilled or objects have fallen into the apparatus, the apparatus has been exposed to rain or moisture, does not operate normally, or has been dropped.
15. Object or liquid entry  
WARNING – Take care that objects do not fall and liquids are not spilled into the enclosure through any openings. The equipment shall not be exposed to dripping or splashing. Liquid-filled objects such as vases should not be placed on the equipment.
16. Climate  
The equipment has been designed for use in moderate climates and in domestic situations.
17. Cleaning  
Unplug the unit from the mains supply before cleaning.  
The case should normally only require a wipe with a soft, lint-free cloth. Do not use chemical solvents for cleaning.  
We do not advise the use of furniture cleaning sprays or polishes as they can cause permanent white marks.
18. Power sources  
Only connect the equipment to a power supply of the type described in the operating instructions or as marked on the equipment.  
The primary method of isolating the equipment from the mains supply is to remove the mains plug. The equipment must be installed in a manner that makes disconnection possible.
19. Abnormal smell  
If an abnormal smell or smoke is detected from the equipment, turn the power off immediately and unplug the equipment from the wall outlet. Contact your dealer and do not reconnect the equipment.
20. Damage requiring service  
The equipment should be serviced by qualified service personnel when:

- A. The power-supply cord or the plug has been damaged, or
- B. Objects have fallen, or liquid has spilled into the equipment, or
- C. The equipment has been exposed to rain, or
- D. The equipment does not appear to operate normally or exhibits a marked change in performance, or
- E. The equipment has been dropped or the enclosure damaged.

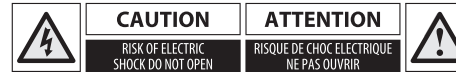

**CAUTION:** To reduce the risk of electric shock, do not remove cover (or back). No user serviceable parts inside. Refer servicing to qualified service personnel.

**WARNING:** To reduce the risk of fire or electric shock, do not expose this apparatus to rain or moisture.



The lightning flash with an arrowhead symbol within an equilateral triangle, is intended to alert the user to the presence of uninsulated 'dangerous voltage' within the product's enclosure that may be of sufficient magnitude to constitute a risk of electric shock to persons.



The exclamation point within an equilateral triangle is intended to alert the user to the presence of important operating and maintenance (servicing) instructions in the literature accompanying the product.

**CAUTION:** In Canada and the USA, to prevent electric shock, match the wide blade of the plug to the wide slot in the socket and insert the plug fully into the socket.

## Class II product

This equipment is a Class II or double insulated electrical appliance. It has been designed in such a way that it does not require a safety connection to electrical earth ("ground" in the U.S.)

## Warning

Mains plug/appliance coupler is used to disconnect device and it shall remain readily operable.

## Safety Compliance

This equipment has been designed to meet the IEC/EN 62368-1 international electrical safety standard.

This device complies with Part 15 of the FCC Rules. Operation is subject to the following two conditions:

1. This device may not cause harmful interference, and
2. This device must accept any interference received, including interference that may cause undesired operation.

The building installation shall be regarded as providing protection in accordance with the rating of the wall socket outlet.

## Caution on installation

For proper heat dispersal, do not install this unit in a confined space, such as a bookcase or similar enclosure.

- More than 0.3m (12in) is recommended.
- Do not place any other equipment on this unit.

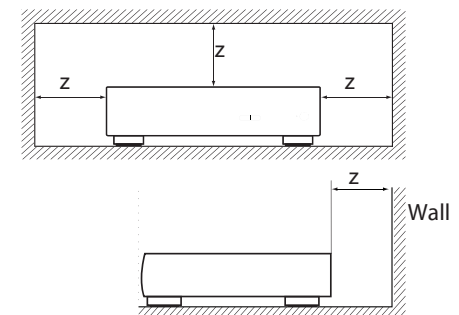

## FCC Information(for US customers)

### PRODUCT

This product complies with Part 15 of the FCC Rules. Operation is subject to the following two conditions:

1. This device may not cause harmful interference, and
2. This device must accept any interference received, including interference that may cause undesired operation.

### IMPORTANT NOTICE: DO NOT MODIFY THIS PRODUCT

This product, when installed as indicated in the instructions contained in this manual, meets FCC requirements. Modification not expressly approved by ARCAM may void your authority, granted by the FCC, to use the product.

### NOTE

This product has been tested and found to comply with the limits for a Class B digital device, pursuant to Part 15 of the FCC Rules. These limits are designed to provide reasonable protection against harmful interference in a residential installation.

This product generates, uses and can radiate radio frequency energy and, if not installed and used in accordance with the instructions, may cause harmful interference to radio communications. However, there is no guarantee that interference will not occur in a particular installation. If this product does cause harmful interference to radio or television reception, which can be determined by turning the product OFF and ON, the user is encouraged to try to correct the interference by one or more of the following measures:

- Reorient or relocate the receiving antenna.
- Increase the separation between the equipment and receiver.
- Connect the product into an outlet on a circuit different from that to which the receiver is connected.
- Consult the local retailer authorized to distribute this type of product or an experienced radio/TV technician for help

## Safety Information (for European customers)

- Avoid high temperatures. Allow for sufficient heat dispersion when installed in a rack.
- Handle the power cord carefully. Hold the plug when unplugging the cord.
- Keep the unit free from moisture, water, and dust.
- Unplug the power cord when not using the unit for long periods of time.
- Do not obstruct the ventilation holes.
- Do not let foreign objects into the unit.
- Do not let insecticides, benzene, and thinner come in contact with the unit.
- Never disassemble or modify the unit in any way.
- Ventilation should not be impeded by covering the ventilation openings with items, such as newspapers, tablecloths or curtains.
- Naked flame sources such as lighted candles should not be placed on the unit.
- Observe and follow local regulations regarding battery disposal.
- Do not expose the unit to dripping or splashing fluids.
- Do not place objects filled with liquids, such as vases, on the unit.
- Do not handle the mains cord with wet hands.
- When the switch is in the OFF position, the equipment is not completely switched off from MAINS.
- The equipment shall be installed near the power supply so that the power supply is easily accessible.

## A note about recycling

This product's packaging materials are recyclable and can be reused. Please dispose of any materials in accordance with the local recycling regulations.

When discarding the unit, comply with local rules or regulations.

Batteries should never be thrown away or incinerated but disposed of in accordance with the local regulations concerning battery disposal.

This product and the supplied accessories, excluding the batteries, constitute the applicable product according to the WEEE directive.

## Correct disposal of this product

These markings indicate that this product should not be disposed with other household waste throughout the EU.



To prevent possible harm to the environment or human health from uncontrolled waste disposal and to conserve material resources, this product should be recycled responsibly.

To dispose of your product, please use your local return and collection systems or contact the retailer where the product was purchased.

## Welcome

### **Thank you and congratulations...**

...for purchasing your Arcam PA720, PA240 or PA410 power amplifier.

Arcam has been producing specialist audio products of remarkable quality for over four decades and the new PA720, PA240 and PA410 power amplifiers are the latest in a long line of award-winning Hi-Fi. The design of the HDA range draws upon all of Arcam's experience as one of the UK's most respected audio companies, to produce Arcam's best performing range of multi channel power amplifiers yet – designed and built to give you years of listening enjoyment.

This handbook is a guide to installing and using the PA720, PA240 and PA410 and includes information on the more advanced features. Use the contents list on the next page to guide you to the section of interest.

We hope that your product will give you years of trouble-free operation. In the unlikely event of any fault, or if you simply require further information about Arcam products, our network of dealers will be happy to help you. Further information can also be found on the Arcam website at [www.arcam.co.uk](http://www.arcam.co.uk).

### **Your PA720, PA240 and PA410 development team**

## Contents

### Safety Guidelines

### Welcome

### Overview

Placing The Unit

Interconnect Cables

Power

### Rear Panel Connections and Controls PA720

### Rear Panel Connections and Controls PA240

### Rear Panel Connections and Controls PA410

### Control System Connections

Network and RS232

USB

Trigger IN/OUT

EN-2

EN-4

EN-6

EN-6

EN-6

EN-6

EN-7

EN-8

EN-9

EN-10

EN-10

EN-10

EN-10

### Front Panel Connections and Controls

### Operation

Switching On

Automatic Standby

Network and RS322 in Standby

Muting the Output

Mode switches

### Connecting Sources and Loudspeakers

Bridged Mono Mode - PA240 only

Dual Mono / Bi Amp Mode - PA240 only

### Troubleshooting

### Specifications

PA720

PA240

PA410

### Worldwide Guarantee

EN-11

EN-12

EN-12

EN-12

EN-12

EN-12

EN-12

EN-13

EN-16

EN-17

EN-18

EN-19

EN-19

EN-20

EN-21

EN-22

## Overview

### Arcam's PA720, PA240 and PA410 amplifiers

Arcam's PA720, PA240 and PA410 power amplifiers provide class leading sound quality for the best reproduction of your music.

Drawing on the many years of amplifier design experience at Arcam, these products use the best quality components and engineering practice to produce amplifiers that will give many years of musical pleasure and reliable service.

With a toroidal based power supply, acoustically damped chassis, class G technology (PA240 & PA720), parallel transistor output stages (PA240) and exceptionally low levels of distortion and noise, the PA720, PA240 and PA410 amplifiers are all capable of reproducing music with all its original authority and detail. Rest assured you will be hearing the music just as the artist intended.

The PA720, PA240 and PA410 amplifiers are designed to produce a level of performance that will truly bring music to life.

### Placing The Unit

- Place the amplifier on a level, firm surface, avoiding direct sunlight and sources of heat or damp.
- Do not place the PA720, PA240 or PA410 on top of a power amplifier or other source of heat.
- Do not place the amplifier in an enclosed space such as a bookcase or closed cabinet unless there is good provision for ventilation. The PA720, PA240 and PA410 are designed to run warm during normal operation.
- Do not place any other component or item on top of the amplifier as this may obstruct airflow around the heat-sink, causing the amplifier to run hot. (The unit placed on top of the amplifier would become hot, too).



- Do not place your record deck on top of this unit. Record decks are very sensitive to the noise generated by mains power supplies which will be heard as a background 'hum' if the record deck is too close.
- The normal function of the unit may be disturbed by strong electromagnetic interference. If this occurs, simply reset the unit with the power button, or move the unit to another location.

### Interconnect Cables

We recommend the use of high-quality screened cables that are designed for the particular application. Other cables will have different impedance characteristics that will degrade the performance of your system (for example, do not use cabling intended for video use to carry audio signals). All cables should be kept as short as is practically possible.

It is good practice when connecting your equipment to make sure that the mains power-supply cabling is kept as far away as possible from your audio cables. Failure to do so may result in unwanted noise in the audio signals.

### Power

The amplifier is supplied with a moulded mains plug already fitted to the lead. Check that the plug supplied fits your supply – should you require a new mains lead, please contact your Arcam dealer.

If your mains supply voltage or mains plug is different, please contact your Arcam dealer immediately.

Push the IEC plug end of the power cable into the power socket on the back of the amplifier, making sure that it is pushed in firmly. Plug the other end of the cable into your mains socket and switch the socket on.



# Rear Panel Connections and Controls PA720

### BALANCED XLR AUDIO INPUTS

Connect the XLR outputs of your pre-amplifier.  
See "Connecting Sources and Loudspeakers" on page EN-13.

### INPUT SWITCHES

Allow the PA720 to be configured to different input types  
See "Connecting Sources and Loudspeakers" on page EN-13.

### USB

For software upgrades only.  
See "USB" on page EN-10.

### TRIGGER IN / OUT

Trigger IN allows the PA720 to be turned on or off by an external source.  
Trigger OUT allows the PA720 to control the power state of other connected equipment  
See "Trigger IN/OUT" on page EN-10.

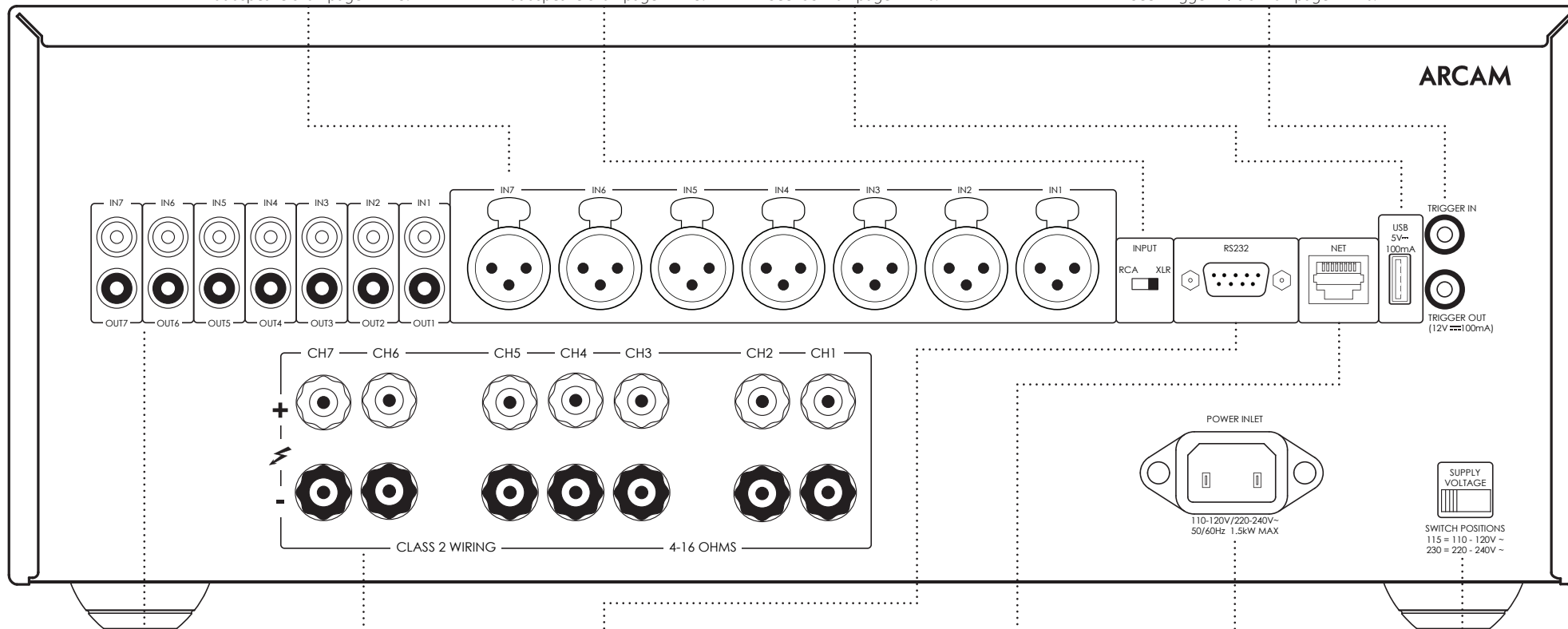

### PRE-AMPLIFIER INPUTS

Connect the phono outputs of your pre-amplifier.  
See "Connecting Sources and Loudspeakers" on page EN-13.

### SPEAKER TERMINALS

See "Connecting Sources and Loudspeakers" on page EN-13.

### RS232

This connection allows for remote control from a third-party home automation system or computer.  
See "Network and RS232" on page EN-10.

### NETWORK

This connection allows for remote control from a third-party home automation system or computer.  
See "Network and RS232" on page EN-10.

### POWER INLET

Connect the correct mains cable here.

### VOLTAGE SELECT

Ensure that the voltage selected matches the local power supply.

### PRE-AMPLIFIER OUTPUT

OUT1-OUT7 provide a copy of the signal applied to the IN1-IN7 phono sockets only, not the XLR.

**Note:** This is a passive output, no additional filtering or amplification is applied.



**Please read the sections "Placing The Unit", "Power" and "Interconnect Cables" on page EN-6 before connecting your PA720 amplifier!**

# Rear Panel Connections and Controls PA240

## BALANCED XLR AUDIO INPUTS

Connect the XLR outputs of your pre-amplifier.

See "Connecting Sources and Loudspeakers" on page EN-13.

## INPUT SWITCHES

Allow the PA240 to be configured in different operational modes.

See "Connecting Sources and Loudspeakers" on page EN-13.

## USB

For software upgrades only. See "USB" on page EN-10.

## TRIGGER IN / OUT

Trigger IN allows the PA240 to be turned on or off by an external source. Trigger OUT allows the PA240 to control the power state of other connected equipment.

See "Trigger IN/OUT" on page EN-10.

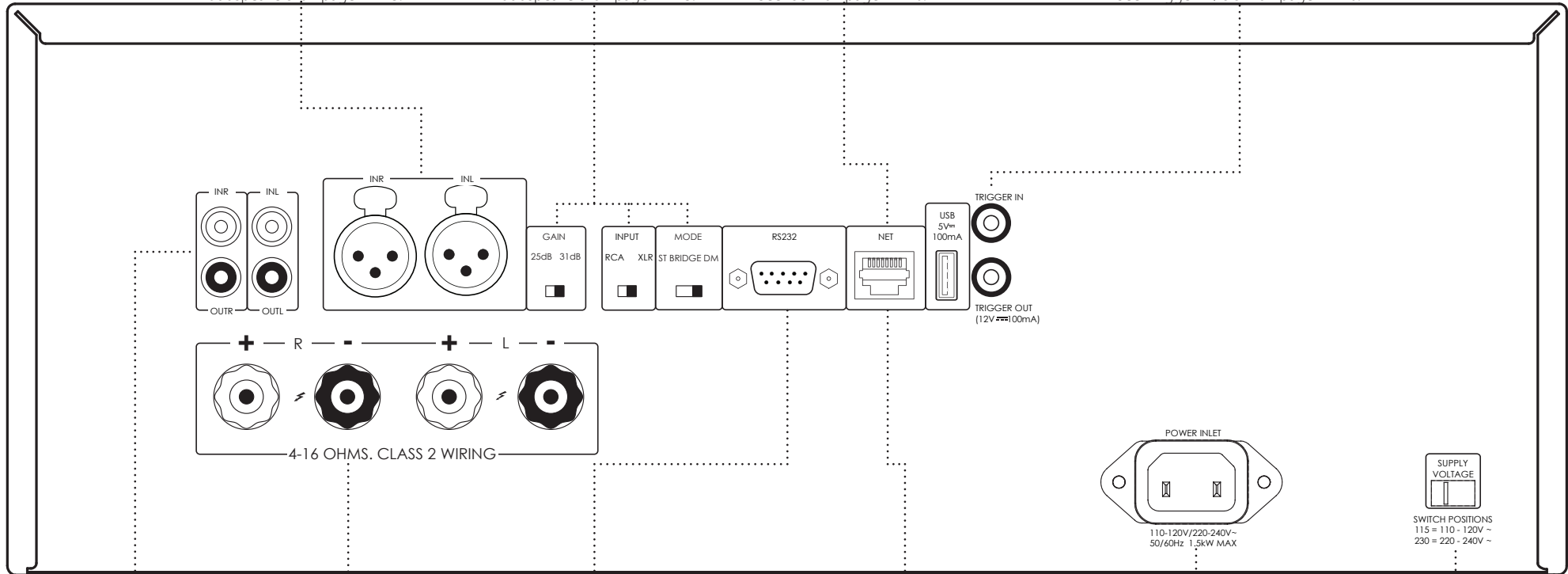

## PRE-AMPLIFIER INPUTS

Connect the phono outputs of your pre-amplifier.

See "Connecting Sources and Loudspeakers" on page EN-13.

## SPEAKER TERMINALS

See "Connecting Sources and Loudspeakers" on page EN-13.

## RS232

This connection allows for remote control from a third-party home automation system or computer.

See "Network and RS232" on page EN-10.

## NETWORK

This connection allows for remote control from a third-party home automation system or computer.

See "Network and RS232" on page EN-10.

## POWER INLET

Connect the correct mains cable here.

## VOLTAGE SELECT

Ensure that the voltage selected matches the local power supply.

## PRE-AMPLIFIER OUTPUT

OUTL and OULR provide a copy of the signal applied to the IN L and IN R phono sockets only, not the XLR.

**Note:** This is a passive output, no additional filtering or amplification is applied.



**Please read the sections "Placing The Unit", "Power" and "Interconnect Cables" on page EN-6 before connecting your PA240 amplifier!**

# Rear Panel Connections and Controls PA410

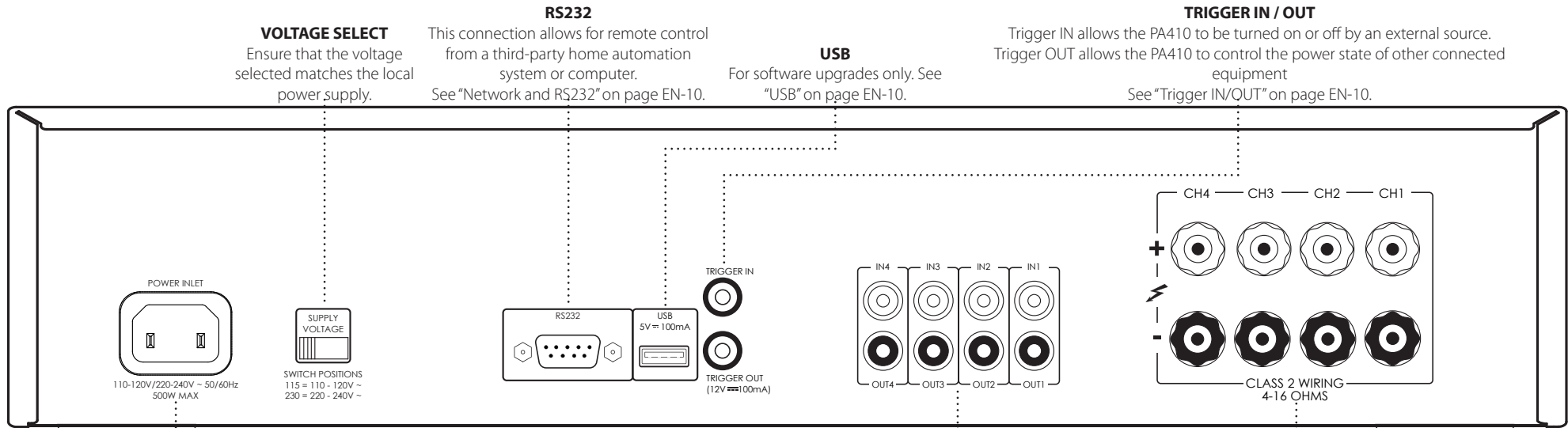

**POWER INLET**  
Connect the correct mains cable here.

**PRE-AMPLIFIER INPUTS**  
Connect the phono outputs of your pre-amplifier. See "Connecting Sources and Loudspeakers" on page EN-13.

**PRE-AMPLIFIER OUTPUT**  
OUT1 to OUT4 provide a copy of the signal applied to the IN1 to IN4 phono sockets.

**Note:** This is a passive output, no additional filtering or amplification is applied.

**SPEAKER TERMINALS**  
See "Connecting Sources and Loudspeakers" on page EN-13.

 The PA410 is designed to run warm in normal use, however extended use at high volume levels can result in the amplifier casework becoming hot to the touch.

 Please read the sections "Placing The Unit", "Power" and "Interconnect Cables" on page EN-6 before connecting your PA410 amplifier!

# Control System Connections

## Network and RS232

The PA720, PA240 and PA410 feature a network and RS232 port that can be used to connect to a local network, computer or home automation system so that the amplifier can be controlled and monitored remotely.

Various third party systems are available providing sophisticated control over all of your entertainment devices. Contact your dealer or installer for details.

For technical details of control protocols please refer to the PA720 / PA240 / PA410 RS232/IP control document, available for download at [www.arcam.co.uk](http://www.arcam.co.uk), for further information.

**Note:** By default, network and RS232 control is disabled in standby to minimise standby power consumption. To enable network control see "Network and RS232 in Standby" on page EN-12.

## USB

The USB port is used for software updates only. For the latest software as well as further information, please visit [www.arcam.co.uk](http://www.arcam.co.uk).

## Trigger IN/OUT

The power state of the PA720, PA240 and PA410 can be controlled by compatible audio/video sources (such as an Arcam AVR). In this case, connect the TRIGGER OUT of the source to the TRIGGER IN of the PA720, PA240 or PA410 using a mono 3.5mm jack lead.

Similarly, the PA720, PA240 and PA410 can control the power state of compatible product (such as another PA720, PA240 or PA410). In this case, connect the TRIGGER IN of the source to the TRIGGER OUT of the PA720, PA240 or PA410 using a mono 3.5mm jack.

**Note:** These leads are not supplied.

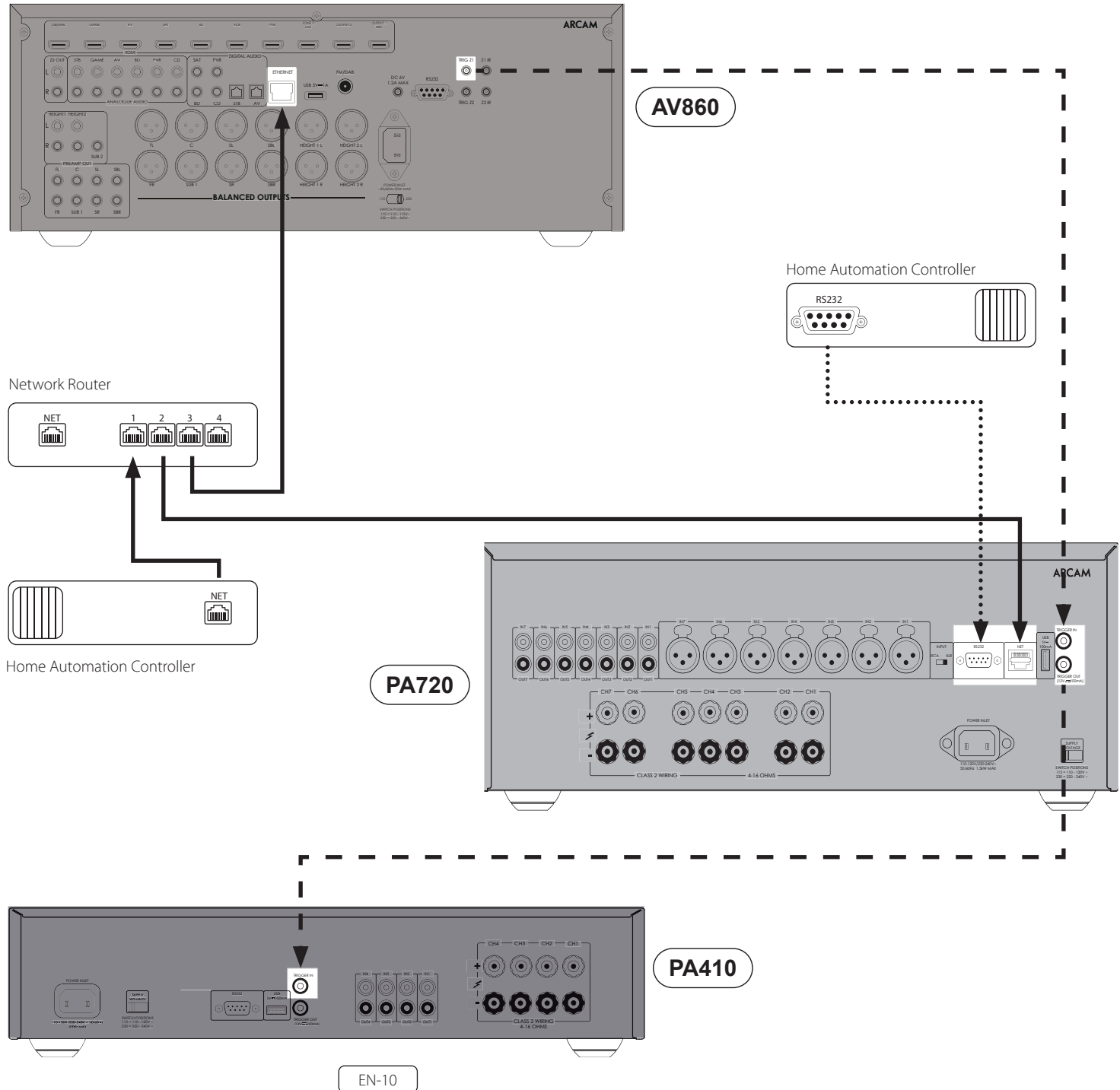

# Front Panel Connections and Controls

**POWER INDICATOR AND POWER SWITCH**  
See "Switching On" on page EN-12.

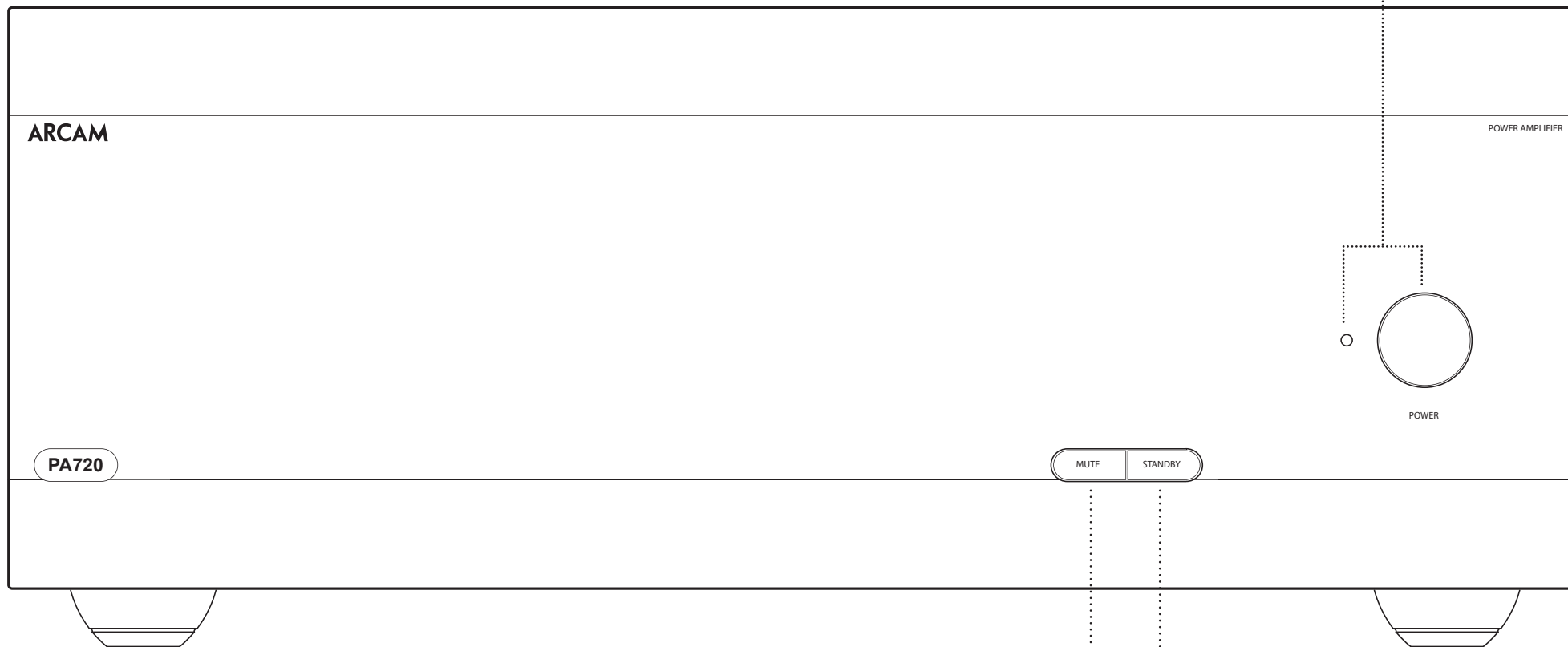

**MUTE**  
Mute / unmute the PA720, PA240 or PA410 speaker outputs.  
See "Muting the Output" on page EN-12.

**UNIT STANDBY**  
See "Switching On" on page EN-12.

# Operation

## Switching On

The **POWER** button switches the unit on and off. The status indicator LED indicates the state of the amplifier: it changes from red to orange then white if mains power is connected and the unit is switched on.

Pressing the **STBY** button while the unit is powered on, will place the PA720, PA240 or PA410 into standby mode. Press the **STBY** button again to bring the unit out of standby.

## Automatic Standby

In order to comply with international regulations for consumer products, this unit is designed to enter standby mode if no user interaction and no audio input signal are detected for an extended period of time (default is 20 minutes). The unit can be brought out of standby by pressing the **STBY** button on the front panel, the trigger input or RS232 or ethernet command (if enabled, see "Network and RS322 in Standby" for more information)

The standby time out can be adjusted using either RS232 or IP control commands. Please refer to the PA720 / PA240 / PA410 RS232/IP control document, available for download from [www.arcam.co.uk](http://www.arcam.co.uk).

Alternatively pressing and holding the **MUTE** button will toggle the standby time out between OFF and 20 minutes.

The LED will flash to indicate the setting change, red for OFF, green for 20 minutes.

**Note:** if the standby time-out is set to OFF, the automatic standby feature will be disabled.

## Network and RS322 in Standby

In low power standby mode the network and RS322 functionality is disabled.

To enable network and RS232 in standby, send a control or status request command to the unit whilst it is powered on.

This will enable whichever control method was used when the unit is in standby.

**Note:** To indicate the unit is not in lowest power standby mode the LED will flash briefly when entering standby mode.

**Note:** Enabling network or RS232 control will increase standby power consumption. To restore the unit to the default low power standby consumption press and hold the **STBY** button for more than 3 seconds or restore the unit to factory defaults.

## Muting the Output

The speaker outputs of the PA720, PA240 or PA410 can be silenced by pressing the **MUTE** button on either the front panel or by sending the relevant command via either the RS232 or network connection.

If the unit is muted, front panel power indicator will change to orange.

To cancel the mute, press the **MUTE** button again or send the relevant command via either the RS232 or network connection.

## Mode switches

The various mode switches located on the rear of the PA720 and PA240 amplifiers allow you to configure your power amplifier to your specific equipment setup. See "Connecting Sources and Loudspeakers" on page EN-13 for more information.

### INPUT (PA720 and PA240 only)

This switch selects between the XLR and RCA phono inputs of the amplifier. Select whichever connection method you are using to connect your preamp.

### GAIN(PA240 only)

This switch allows the gain to be changed from standard Arcam gain of 31dB (which matches all Arcam amplifiers and receivers) to 26dB. This allows flexibility to connect multiple PA240 amplifiers in different modes to multiple speakers.

In normal set-ups this switch should be left at 31dB.

### MODE (PA240 only)

This switch selects between the different amplification modes of the PA240.

#### STEREO (ST)

This is the standard stereo amplification mode using two separate preamp inputs driving two separate speaker outputs.

#### DUAL MONO (DM)

This mode allows two separate speakers to be driven from a single preamp input.

Alternatively the two drivers of a single speaker can be bi-amped from a single PA240.

#### BRIDGED MONO (BRIDGE)

This mode uses both channels of the PA240 to drive a single speaker. This is the ultimate in high power, high fidelity amplification.

# Connecting Sources and Loudspeakers

## PA720

Connect the **RED** positive speaker terminal labelled **CH1 to CH7+** to the positive terminal of your speaker. Similarly, connect the **BLACK** negative speaker terminal of the same channel to the negative terminal of your speaker.

Repeat this process for the other speakers, using the same respective input and speaker terminals for each channel.

**NOTE:** All the channels are identical so there is no requirement to connect specific AVR output channels to specific amplifier channels.

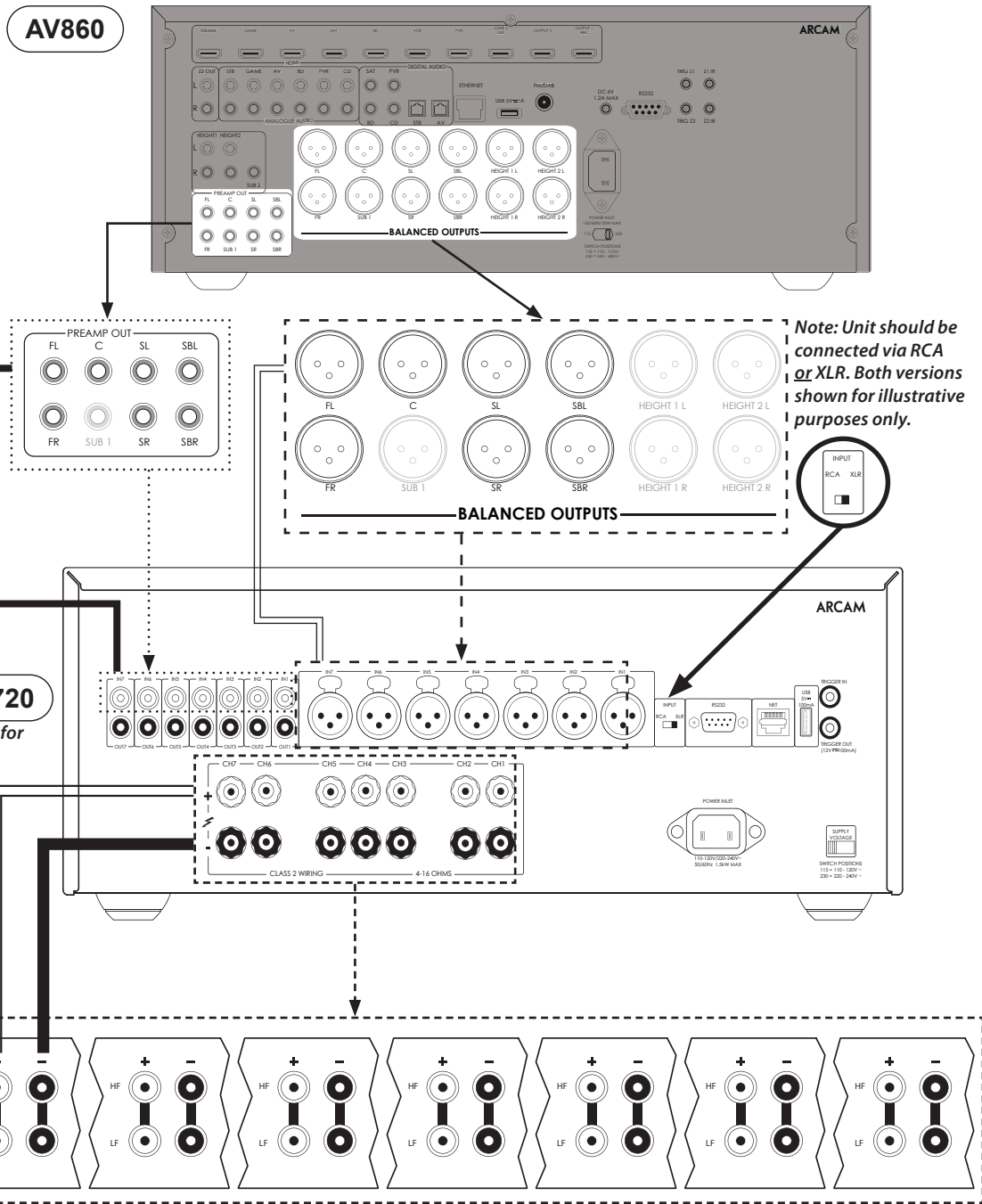

*Note: Single channel shown for clarity*

## Notes On Making Speaker Connections

- Do not make any connections to any amplifier while it is switched on. We recommend that your amplifier is completely disconnected from the mains supply before starting.
- Before switching your amplifier on for the first time after connecting to speakers, please check all connections thoroughly. Ensure that bare wires or cables are not touching each other or the amplifier's chassis (which could cause short circuits), and that you have connected positive (+) to positive and negative (-) to negative. Be sure to check the wiring for both the amplifier and the speaker.
- After making connections: switch the amplifier on then gradually increase the volume to the required listening level.
- If you are unsure as to how your system should be connected, please contact your Arcam dealer who will be happy to help you.

## PA240

Connect the **RED** positive speaker terminal labelled **L+** to the positive terminal of your speaker. Similarly, connect the **BLACK** negative speaker terminal labelled **L-** to the negative terminal of your speaker.

Repeat this process for the right speaker.

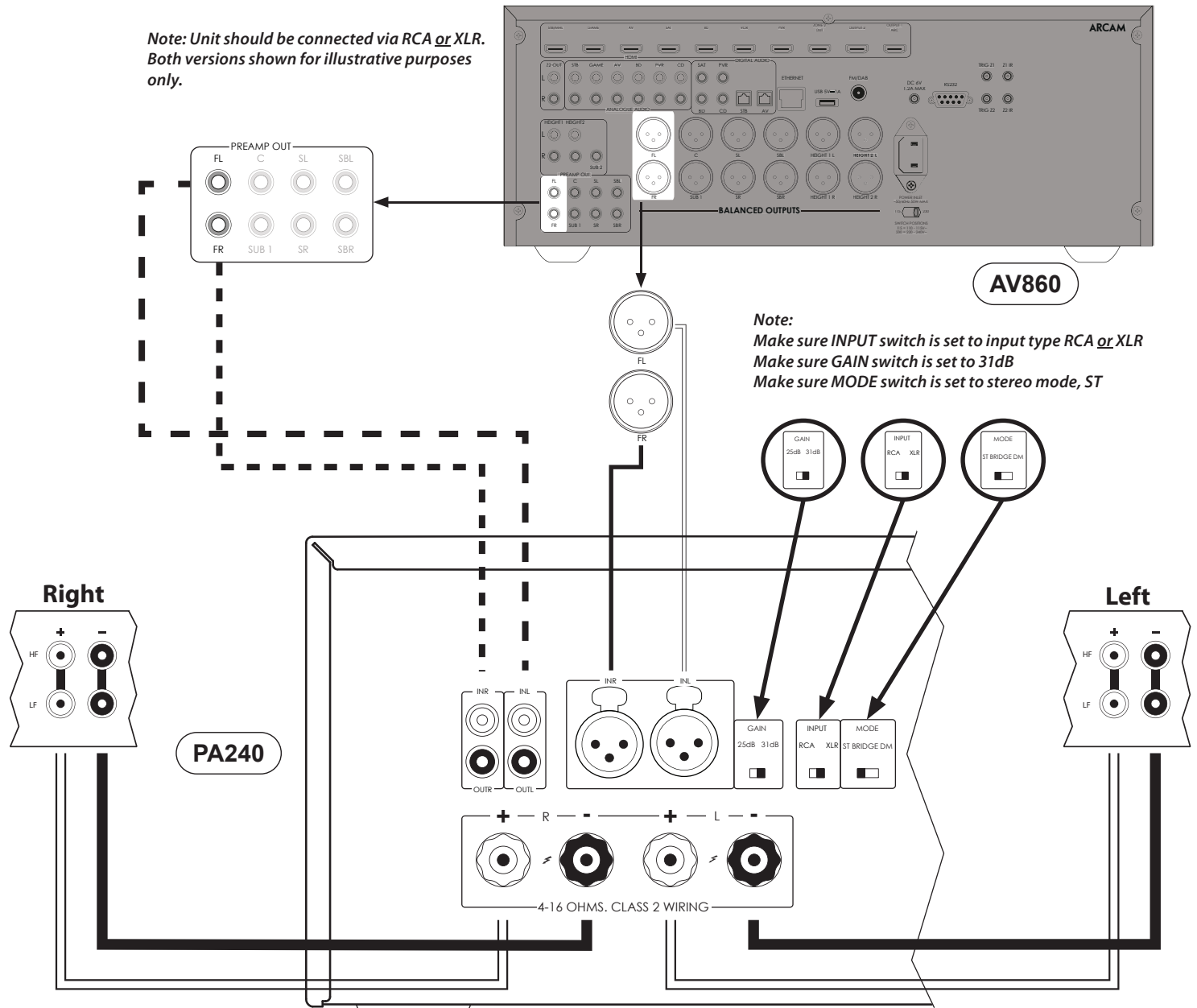



### PA410

Connect the **RED** positive speaker terminal labelled **CH1 to CH4+** to the positive terminal of your speaker. Similarly, connect the **BLACK** negative speaker terminal of the same channel- to the negative terminal of your speaker.

Repeat this process for the other speakers, using the same respective input and speaker terminals for each channel.

**NOTE:** All the channels are identical so there is no requirement to connect specific AVR output channels to specific amplifier channels.

### AV860

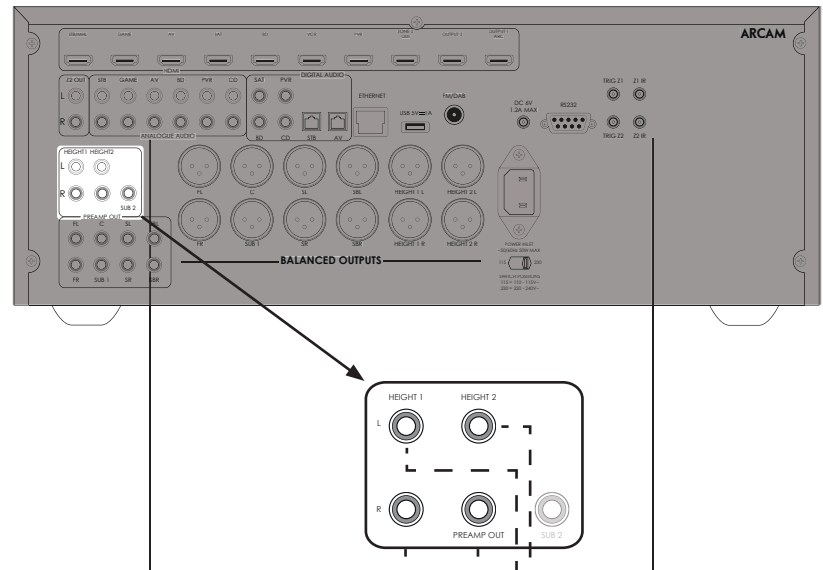

### PA410

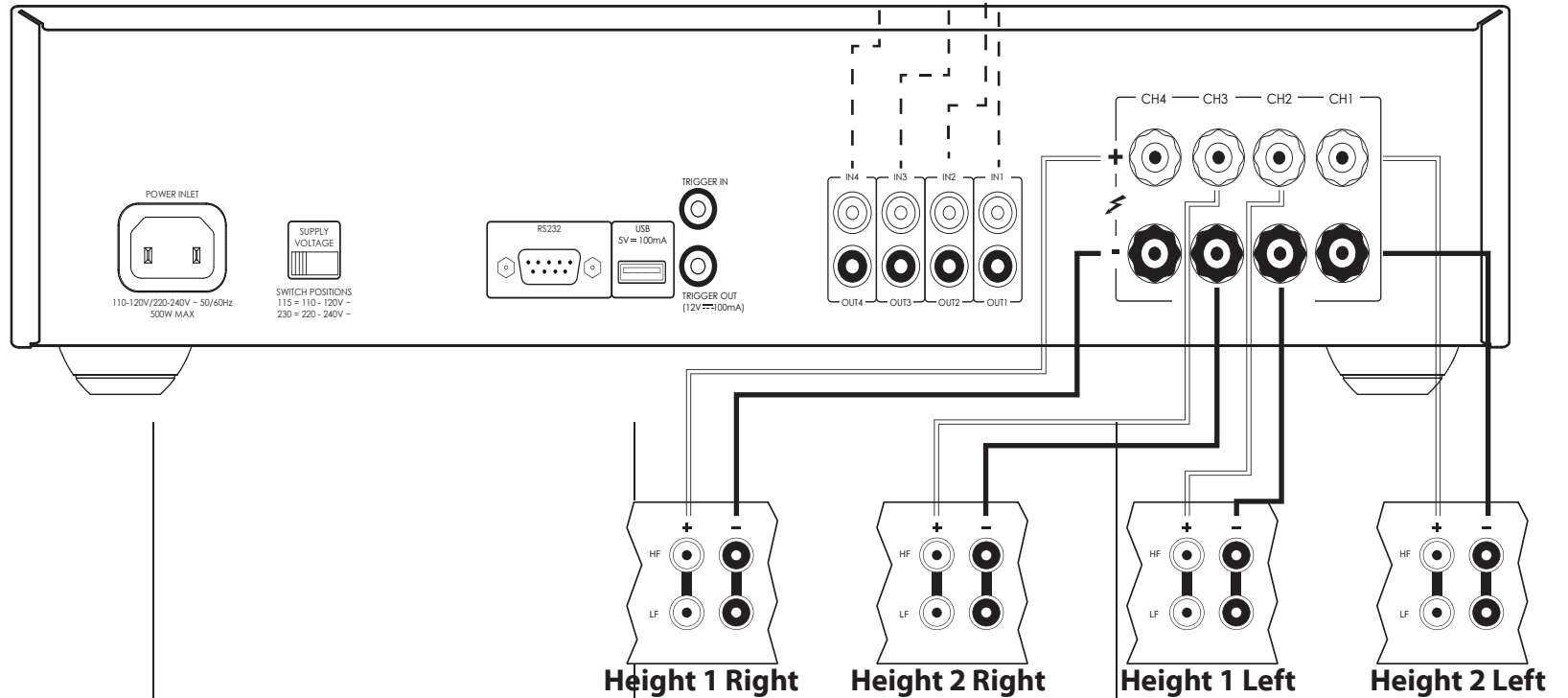

## Bridged Mono Mode - PA240 only

Bridged mono mode requires the use of a PA240 for each channel.

**Note:** In bridged mode only the **L+** and **R+** speaker outputs are required.

**WARNING:** Do not make any connections to the **L-** or **R-** speaker terminals, doing so will severely damage your amplifier.

On one of the PA240's, connect the **RED** positive speaker terminal labelled **L+** to the positive terminal of your left speaker.

Connect the **RED** positive speaker terminal labelled **R+** to the negative terminal of your left speaker.

Repeat this process for the right speaker, using the **SAME** terminals on the other PA240.

**Note:** **L+** must be connected to the positive speaker terminal and **R+** to the negative speaker terminal on **BOTH** speakers otherwise the speakers will be out of phase.

**WARNING:** Make **ABSOLUTELY** sure you have used the **L+** and **R+** terminals of the PA240. **L-** and **R-** terminals are **NOT** required in this arrangement.

In this setup only one interconnect is required to each power amplifier and it should be connected to the **IN L** input. The interconnects can be either XLR (recommended for longer cable runs) or phono (RCA). Set the INPUT switch on both of the PA240's to the appropriate setting for the cables used.

**Note:** The **IN R** input has no function in this arrangement.

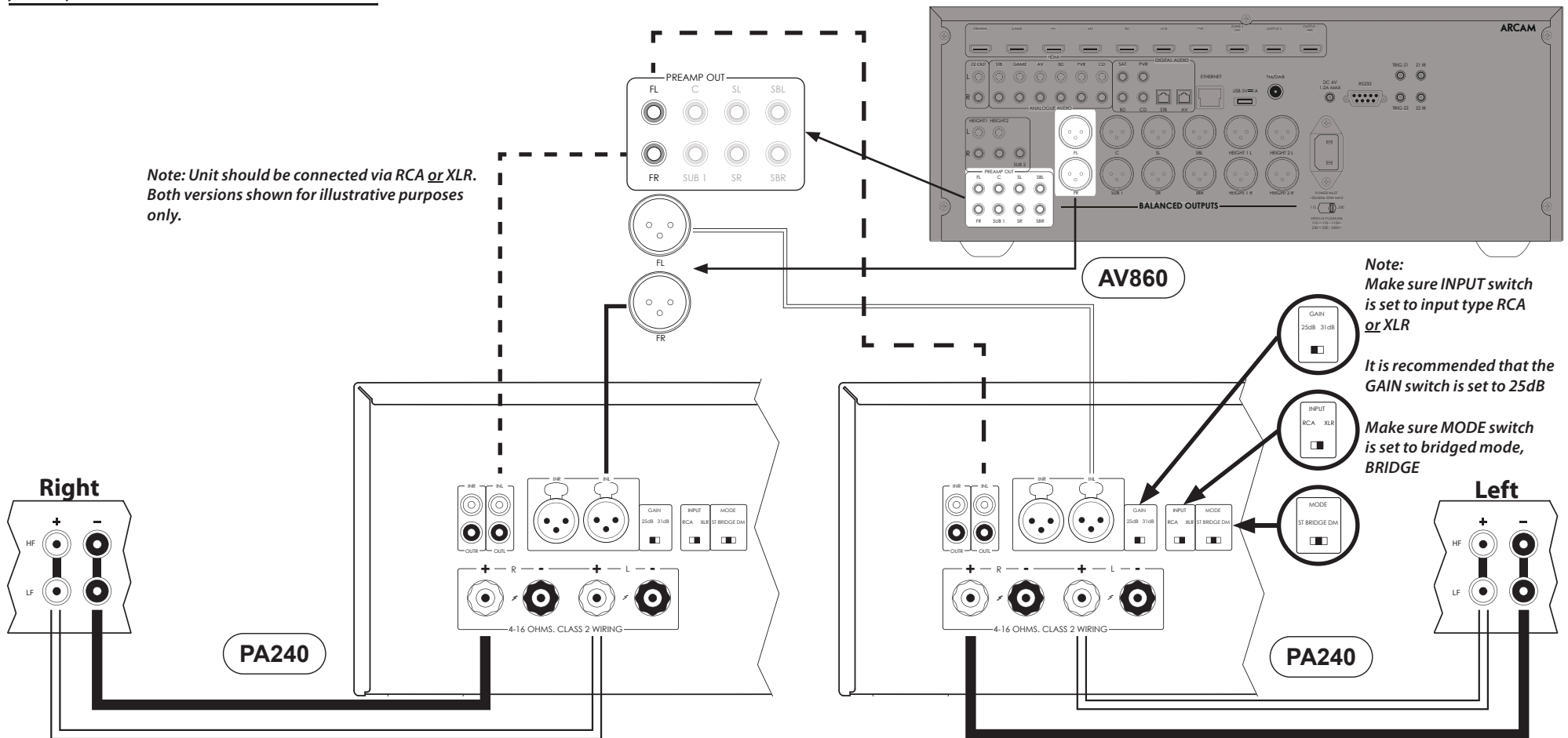

## Dual Mono / Bi Amp Mode - PA240 only

Dual mono requires the use of a PA240 for each channel. On one of the PA240's, connect the **RED** positive speaker terminal labelled **L+** to the positive LF terminal of your left speaker. Similarly, connect the **BLACK** negative speaker terminal labelled **L-** to the negative LF terminal of your left speaker.

**WARNING:** Speakers that support biamping have a metal strip that connects the low frequency (LF) and high frequency (HF) terminals. This **MUST** be removed in a bi-amped system

Using a second speaker cable connect the **RED** positive speaker terminal labelled **R+** to the positive HF terminal of your left speaker. Similarly, connect the **BLACK** negative speaker terminal labelled **R-** to the negative HF terminal of your speaker.

Repeat this process for the right speaker, using the same terminals on the other PA240.

In this setup only one interconnect is required to each power amplifier and it should be connected to the **IN L** input. The interconnects can be either XLR (recommended for longer cable runs) or phono (RCA). Set the INPUT switch on both of the PA240's to the appropriate setting for the cables used.

**Note:** The **IN R** input has no function in this arrangement.

Note: Unit should be connected via **RCA or XLR**. Both versions shown for illustrative purposes only.

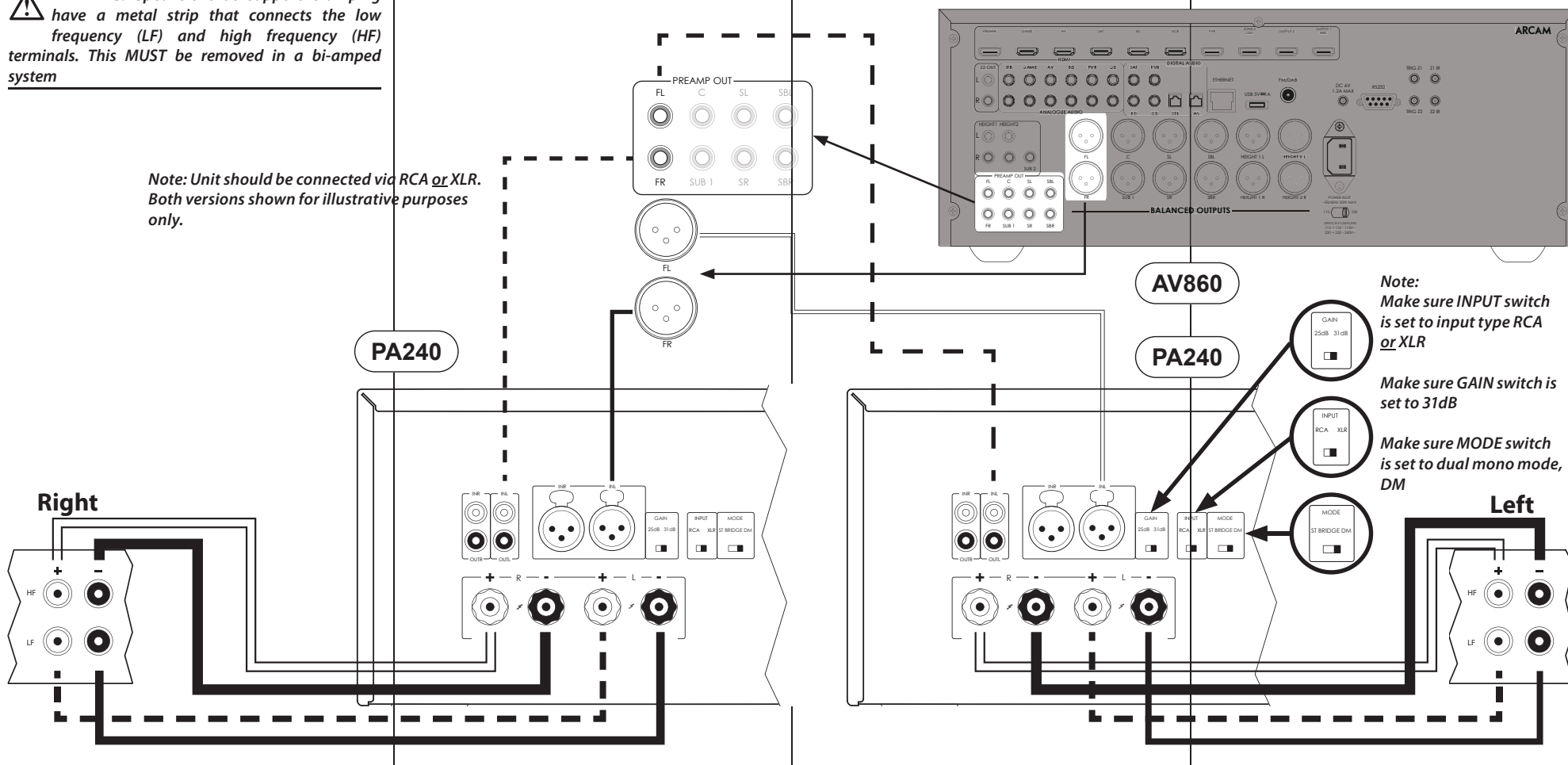

Note: Make sure **INPUT** switch is set to input type **RCA or XLR**  
 Make sure **GAIN** switch is set to **31dB**  
 Make sure **MODE** switch is set to **dual mono mode, DM**

## Troubleshooting

Problem	Check the following
No sound	<ul style="list-style-type: none"><li><input type="checkbox"/> The PA720 / PA240 / PA410 power amplifier is correctly plugged in and switched on.</li><li><input type="checkbox"/> Your audio/video source (e.g. pre amplifier) is correctly connected.</li><li><input type="checkbox"/> The PA720 / PA240 / PA410 is not in protection mode, as described in the next section.</li><li><input type="checkbox"/> The PA720, PA240 and PA410 is not muted.</li></ul>
Sound cuts-out unexpectedly	<p>The PA720 / PA240 / PA410 may enter a protection mode, depending on the fault being detected. The front panel LED will indicate the fault type, according to the list below.</p> <ul style="list-style-type: none"><li><input type="checkbox"/> FLASHING WHITE: The internal temperature of the unit reached an unsafe level. Allow the PA720 / PA240 / PA410 to cool off.</li><li><input type="checkbox"/> FLASHING RED: The PA720 / PA240 / PA410 amplifier detected a speaker short circuit. Should this happen, please inspect all the speaker cables to make sure none of them are shorted together. This fault is very common when bare wires are being used to make speaker connections.</li><li><input type="checkbox"/> FLASHING ORANGE: PA720 and PA240 only. The amplifier detected a DC offset.</li></ul> <p>Following any of the faults described above, the amplifier will turn itself off and power to the speakers will be removed. To continue using the PA720 / PA240 / PA410, the fault must be removed and the unit must be turned OFF then back ON.</p>

# Specifications

## PA720

Continuous power output at 0.2% THD per channel		
Seven channels driven, 4Ω / 8Ω, 1kHz	140W / 100W	
Five channels driven, 4Ω / 8Ω, 1kHz	175W / 110W	
Two channels driven, 4Ω / 8Ω, 1kHz	225W / 140W	
Harmonic distortion, 80% power, 8Ω at 1kHz	0.002%	
Inputs		
	RCA Type	XLR Type
Input sensitivity 100W / 8Ω	800mV RMS	1.6V RMS
Signal/Noise ratio (A-wtd) 100W / 8Ω	112dB	
Input impedance	10kΩ	
Frequency response	20 - 20kHz +/-0.05dB	
General		
Mains voltage	110–120V or 220–240V, 50–60Hz	
Maximum power consumption	1.5kW	
Low power standby consumption	0.5W	
Network standby consumption	2W	
Dimensions W x H x D (including feet, control knob and speaker terminals)	433 x 425 x 177mm	
Weight (net)	18kg	
Weight (gross)	19.7kg	

*All specification values are typical unless otherwise stated. Arcam has a policy of continuous improvement for its products. This means that designs and specifications are subject to change without notice. E&OE.*

## PA240

Continuous power output at 0.2% THD per channel				
Two channels driven, 4Ω / 8Ω, 1kHz	380W / 225W			
One channel driven, 8Ω bridged mode, 1kHz	790W			
Harmonic distortion, 80% power, 8Ω at 1kHz	0.001%			
Inputs				
	RCA Type		XLR Type	
	31dB	25dB	31dB	25dB
Input sensitivity 200W / 8Ω	1.15V RMS	2.3V RMS	2.3V RMS	4.6V RMS
Signal/Noise ratio (A-wtd) 10W / 8Ω	110dB	114dB	110dB	114dB
Input impedance	10kΩ			
Frequency response	20 - 20kHz +/-0.05dB			
General				
Mains voltage	110–120V or 220–240V, 50–60Hz			
Maximum power consumption	1.5kW			
Low power standby consumption	0.5W			
Network standby consumption	2W			
Dimensions W x H x D (including feet, control knob and speaker terminals)	433 x 425 x 177mm			
Weight (net)	18kg			
Weight (gross)	19.7kg			

*All specification values are typical unless otherwise stated. Arcam has a policy of continuous improvement for its products. This means that designs and specifications are subject to change without notice. E&OE.*

## PA410

Continuous power output at 0.2% THD, per channel	
Four channels driven, 4Ω / 8Ω, 1kHz	70W / 50W
Two channels driven, 4Ω / 8Ω, 1kHz	90W / 60W
Harmonic distortion, 80% power, 8Ω at 1kHz	0.003%
Inputs	
Input sensitivity 50W / 8Ω	560mV RMS
Signal/Noise ratio (A-wtd) 50W / 8Ω	106dB
Input impedance	10kΩ
Frequency response	20 - 20kHz +/-0.2dB
General	
Mains voltage	110–120V or 220–240V, 50–60Hz
Maximum power consumption	700W
Low power standby consumption	0.5W
Dimensions W x H x D (including feet, control knob and speaker terminals)	433x325x105mm
Weight (net)	10kg
Weight (gross)	11.5kg

*All specification values are typical unless otherwise stated. Arcam has a policy of continuous improvement for its products. This means that designs and specifications are subject to change without notice. E&OE.*

## Worldwide Guarantee

This entitles you to have the unit repaired free of charge, during the first five years after purchase, provided that it was originally purchased from an authorised Arcam dealer. The Arcam dealer is responsible for all after-sales service. The manufacturer can take no responsibility for defects arising from accident, misuse, abuse, wear and tear, neglect or through unauthorised adjustment and/or repair, neither can they accept responsibility for damage or loss occurring during transit to or from the person claiming under the guarantee.

### The warranty covers:

Parts (excluding disc drives) and labour costs for five years from the purchase date (see below for additional terms and conditions). After five years you must pay for both parts and labour costs.

*Disc drives (of any type) are covered under this warranty for two years from the purchase date.*

*The warranty does not cover battery replacement at any time.*

*The warranty does not cover transportation costs at any time.*

## Claims under guarantee

This equipment should be packed in the original packing and returned to the dealer from whom it was purchased. It should be sent carriage prepaid by a reputable carrier – **not by post**. No responsibility can be accepted for the unit whilst in transit to the dealer or distributor and customers are therefore advised to insure the unit against loss or damage whilst in transit.

For further details contact Arcam at [arcam.support@harman.co.uk](mailto:arcam.support@harman.co.uk).

## Problems?

If your Arcam dealer is unable to answer any query regarding this or any other Arcam product please contact Arcam Customer Support at the above address and we will do our best to help you.

## On-line registration

You can register your product on-line at [www.arcam.co.uk](http://www.arcam.co.uk).





**ARCAM**

[WWW.ARCAM.CO.UK](http://WWW.ARCAM.CO.UK)

THE WEST WING, STIRLING HOUSE

WATERBEACH, CAMBRIDGESHIRE, CB25 9PB

+44 (0) 1223 203200