

# IWCB Series

IWCB-52, IWCB-525 & IWCB-626  
In Wall Closed Box Speakers

IWCB-52



IWCB-525



IWCB-626



**AVAILABLE AT  
DIGITAL CINEMA**

**Atlantic**  
TECHNOLOGY

Instruction Manual

## Table of Contents

- 2 Model IWCB-52, -525, -626**
- 3 Important Considerations Before Installation**
  - 3 Recommended Wire Sizes
  - 3 Location Considerations
  - 3 Room Acoustics
- 3 Speaker Placement**
  - 3 Stereo Music Listening
  - 4 Home Theater Systems
- 5 Mounting the IWCB Speakers**
- 5 Installation of the IWCB in New Construction**
- 5 Installation of the IWCB in Existing Construction**
  - 5 Removing and Installing the Grille
  - 5 Cutting the Opening
  - 6 Installing the Mounting Frame
  - 6 Painting the Speaker Assembly
  - 6 Speaker Connection and Assembly
  - 6 Installing the Speaker Enclosure Into the Frame
- 7 Front Panel Controls**
  - 7 HF (High Frequency) Level Control
  - 7 Boundary Compensation Control
  - 7 Directional Vector Control™
  - 7 IR Knockout
- 7 Specifications**

# Model IWCB-52, -525, -626

## In Wall Closed Box Speakers

Thank you for purchasing Atlantic Technology products. Our speaker systems have been designed to deliver exceptional sound and value. We hope you like what you hear from them, and are happy with your decision to buy them.

Please take a few moments to read these instructions. They're intended not only to tell you how to mount the speakers, but how to get the best performance from them.

## For Future Reference

Record your serial numbers and date of purchase here:

Model Number \_\_\_\_\_

Serial Number \_\_\_\_\_

Date of Purchase \_\_\_\_\_

The serial number is found on the back panel.

Copyright © 2006 Atlantic Technology International.

Specifications are those in effect at the time of printing. Atlantic Technology reserves the right to change specifications or designs at any time without notice.

## Important Considerations Before Installation

### Recommended Wire Sizes

The longer the wire run, the heavier the wire should be. Use the following recommendations as a guide for your installation. And if you're in doubt, remember that it never hurts to get the next heavier grade of wire. Also note that lower gauge numbers equal heavier wire sizes.

#### Wire Run Wire Gauge:

<15 ft. 16 ga.  
15 to 30 ft. 14 ga.  
>30 to 50 ft. 12 ga.

### Location Considerations

A major determinant of any speaker's sound quality is its location in the room. With in-wall speakers there are fewer placement options than with free-standing speakers, so giving some thought to location can really pay off. Our In-Wall Closed Box systems have been designed to minimize the detrimental effects wall mounting can have on sound, so they sound better than conventional open-back in-wall speakers.

### Room Acoustics

Hard surfaces create lots of sound reflections in the room while soft surfaces tend to absorb sound. Note the speakers' location in terms of proximity to glass and other highly sound reflective or absorptive surfaces. A simple set of curtains or an area rug can make a major difference in sound quality and intelligibility by reducing excessive reflections.

## Speaker Placement

For all the following situations, it's recommended that you first place small box speakers in the proposed locations, just to get a good idea of how that location will sound. In-wall speakers are tough to move once they're installed!

**IMPORTANT:** Using Atlantic's Exclusive Directional Vector Control™ (see Page 7 for more details)

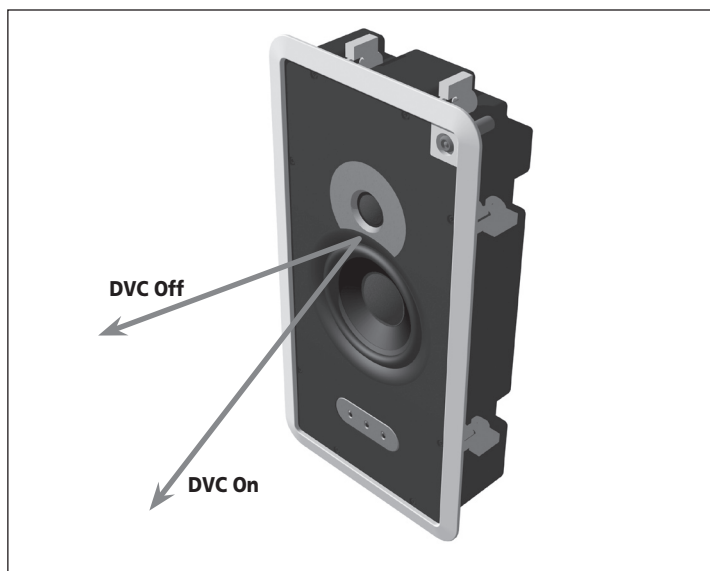

For all the following placement instructions, it's important to bear in mind that for aesthetic considerations, many people prefer to mount their in-wall speakers well above seated ear level, as doing so minimizes the speakers' visual intrusion on the room.

In those cases, simply engage the DVC "on" and the midrange output of the speakers—which determines both intelligibility and localizability—is directed down towards the listener's ears, even though the speakers are mounted high up on the walls.

For those situations where localizability is not desired, such as background music (sometimes called "whole-house audio") or surround channel use, leave the DVC "off."

### Stereo Music Listening

For stereo music reproduction, place the speakers at approximately ear level when seated, with both speakers on the same wall facing the prime listening location. A separation of approximately 6 to 8 feet between the left and right speakers is usually good. Ideally, the distance between the two speakers will be close to the same as the distance from the speakers to the listening position.

## Home Theater Systems

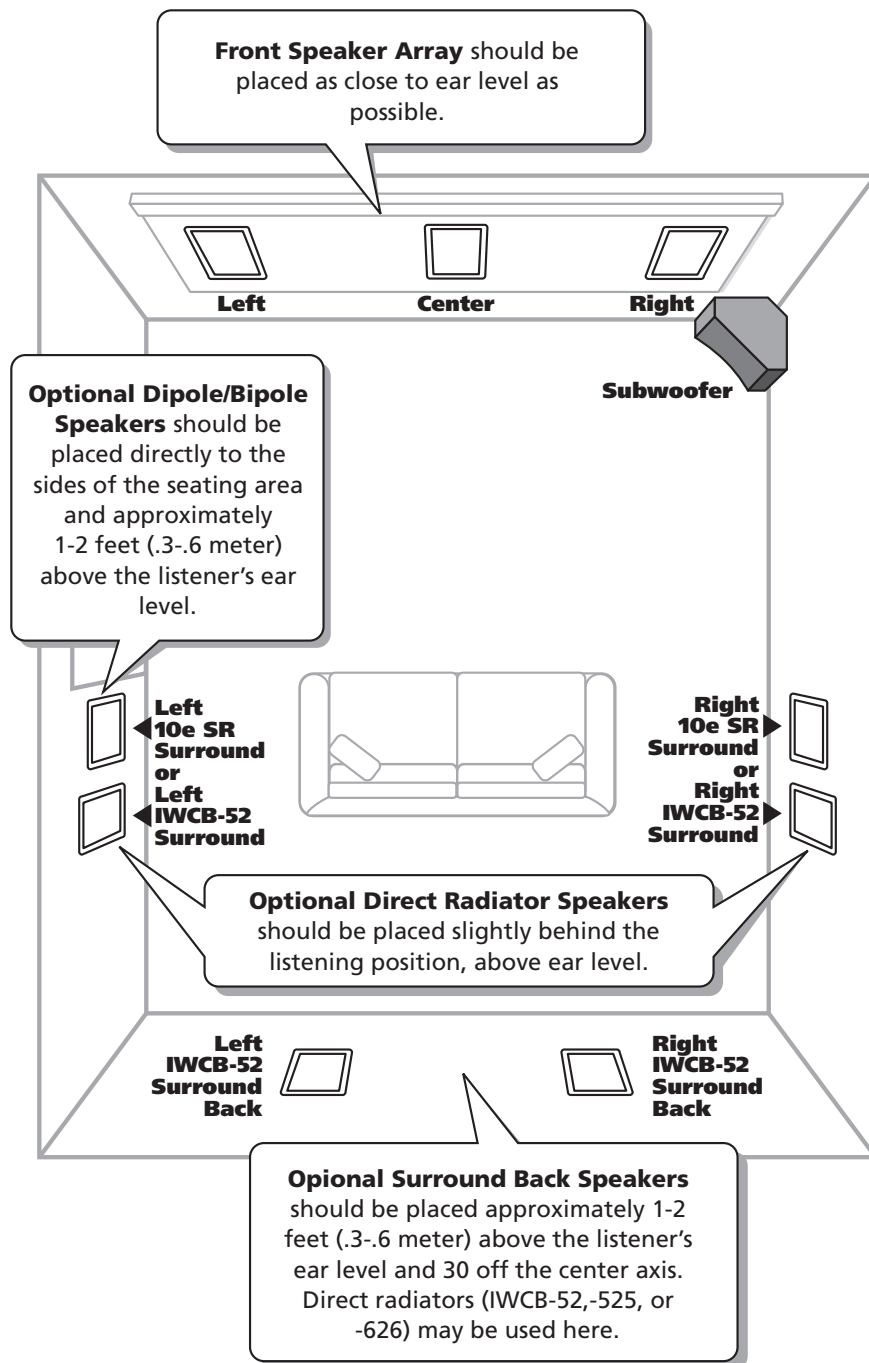

Today's home theater systems require you to place six or more speakers in your room. For the most convincing theater effects, speaker placement must be very carefully thought out. This is especially true with in-wall speakers, since their installation is permanent!

**Left/Center/Right Locations** The front three speakers should be at or just above ear height when seated, just as with stereo speakers. Try to keep the vertical position of the three front speakers within 18 inches of each other, as this will maintain smooth, believable left-center-right pans.

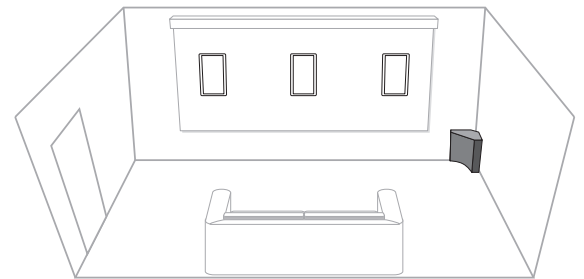

The spacing of the left-right speakers can be a little wider than with 2-channel stereo speakers, since in a theater system, the center channel speaker reproduces the on-screen effects and anchors the center image. Left-right spacing of about 8 to 10 feet usually works well.

**Surround Speakers** In order to achieve optimum performance we strongly recommend Atlantic Technology Dipole or TriVector™ surround speakers. If you are using our dedicated surround speakers please follow the placement recommendations included in their installation instructions.

**Non-Dipole Surrounds** The most realistic surround effects occur when the listener can't localize the actual location of the surround speaker. If you decide to use the In-Wall Close Box speakers as surround speakers, mount them above the listeners' ears, slightly behind the listening area either on the side or rear walls. Make sure the DVC is in the "off" position.

## Mounting the IWCB Speakers

**NOTE:** We always recommend a professional be involved in the installation of IWCB speakers.

The IWCB speaker can be easily mounted in most any standard wall material, from ½ to 1½ inches thick. Its rotating wall clamps firmly fix it to the wall surface after the proper cutout has been made. Here are some important precautions to take before mounting:

Keep the sides of the actual mounting hole at least ½ inch away from beams or studs to ensure that the clamps have adequate room to rotate. A stud or other obstruction that's too close will stop them from properly doing their job.

## Installation of the IWCB in New Construction

Atlantic Technology offers an optional Rough-in Frame Kit to ease installation in new construction. Instructions for its use are included with that kit.

## Installation of the IWCB in Existing Construction

### Removing and Installing the Grille

Remove the grille from the speaker using an awl or the point of a drywall screw in a grille opening near one of the grille corners. Slowly pry the grille out, being careful not to damage the speaker's frame or its finish.

To re-install the grille later, press it carefully into the appropriate opening in the frame assembly. Since it's designed to fit snugly, please take your time and use care when installing the grille.

### Cutting the Opening

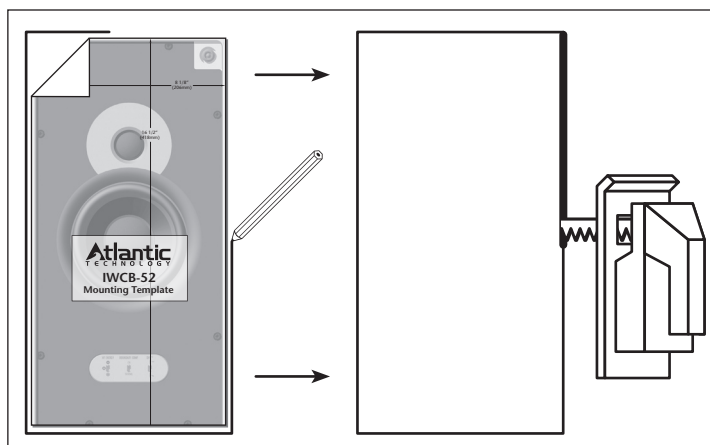

After determining the best location for the speaker as outlined above, use the enclosed template to cut the proper size hole.

<b>IWCB-52</b>	<b>8 1/8" x 16 1/2"</b>
<b>IWCB-525</b>	<b>9 5/8" x 17 7/8"</b>
<b>IWCB-626</b>	<b>11 1/8" x 20 3/8"</b>

**WARNING:** Exercise extreme care before making any wall cuts to ensure that you will not cut through any wires, pipes, or other items that may be in the wall. You may sometimes, but not always, be able to determine the approximate location of wires and pipes by looking at the locations of nearby outlets and plumbing. But their location or absence is never an assurance that there is not something within the wall cavity.

## Installing the Mounting Frame



The clamping mechanism allows the wall material to range from ½ to 1½ inches (13 to 38 mm) in thickness. There must be a minimum depth behind the wall face of 3 ⅝" (92 mm). As noted above, be sure to keep the edges of the cutout at least ½ inch (13 mm) away from any stud or obstruction, as the rotating clamps will not operate properly if you don't. The speaker enclosure (the black box with the drivers mounted in it) is designed to mount into the white frame, after the frame is mounted into the wall.

Insert the frame into the cutout and using a level or square carefully align it so it is level. Tighten the mounting screws, which will cause the attached clamps to rotate and position themselves properly behind the wall.

Continue to tighten until the frame is snug in the wall. You want the bezel to conform to the wallboard, and the frame not to rattle from the speaker's vibration, *but be very careful not to overtighten the screws.*

## Painting the Speaker Assembly

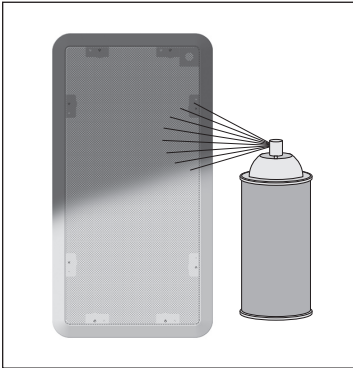

The white plastic frame and the metal grille may be left as is, or painted to match your décor. You can paint the frame before or after it is installed in the wall. Spray painting (using slightly thinned paint) is the best method to use for painting the grille. After painting the grille, use air pressure to "blow out" any grille holes that are filled in with paint.

## Speaker Connection and Assembly

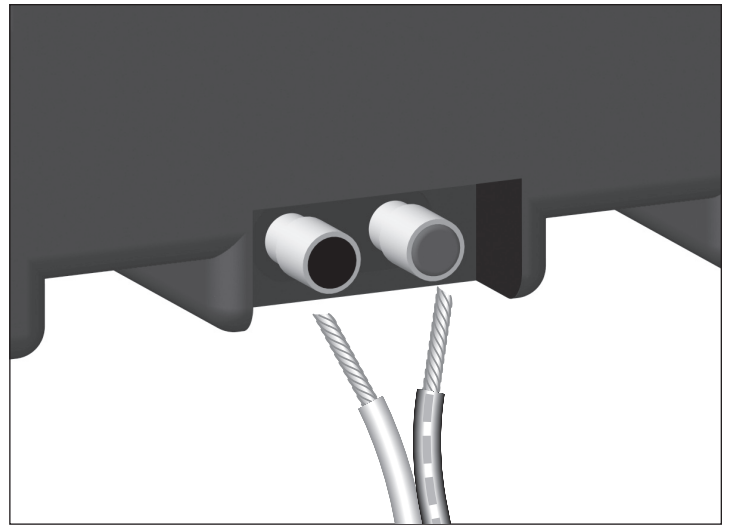

Strip about ½" (13 mm) of insulation from the connecting wires. Connect them to the appropriate push terminal, being careful to observe polarity (positive to the red terminal, negative to the black terminal).

## Installing the Speaker Enclosure into the Frame

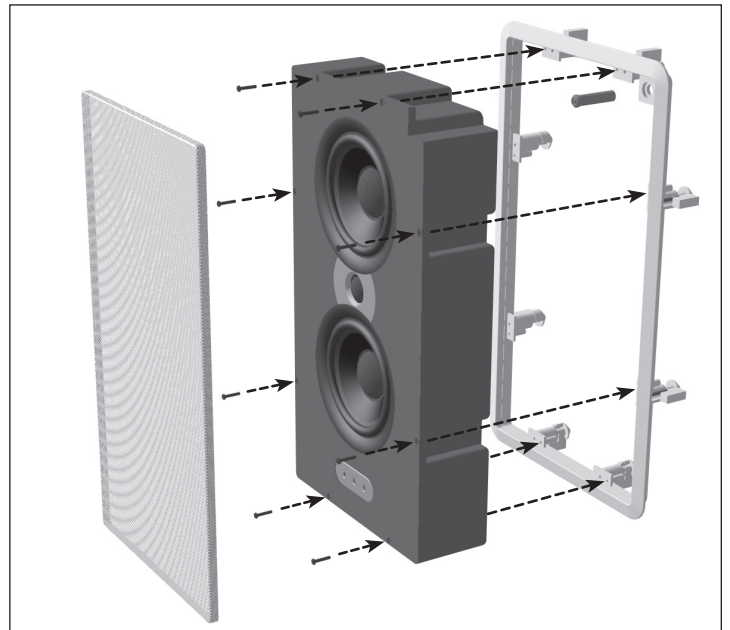

Once the frame is mounted in the wall, the speaker enclosure simply fits into the frame. Note that there is a foam anti-vibration pad affixed to the rear panel of the enclosure. This pad will eliminate any slight vibrations that occur if the back of the speaker enclosure contacts the wallboard in the wall cavity. Due to the usual slight dimensional variances in home construction, the IWCB either may or may not contact the wall surface behind it.

Use the included screws to attach the enclosure to the mounting frame, *but be very careful not to overtighten the screws.*

## Front Panel Controls

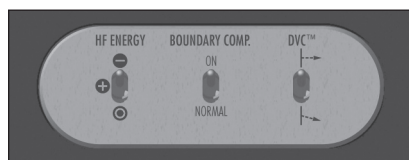

The IWCB speakers have three controls that help optimize the speaker's performance regardless of mounting location or room acoustics.

### HF (High Frequency) Level Control



This control adjusts the relative level of high frequency output to compensate for varying room acoustics or placement behind a screen.

“+” is for absorptive, acoustically “dead” rooms (or when the speaker is behind a movie screen). Use this position to increase the HF level and restore the proper sparkle and liveliness to the sound.

“0” is for rooms of average absorptive characteristics.

“-” should be used in rooms that are highly reflective, with hard floors and exposed windows.

The setting of the HF control is mostly a matter of personal taste, so try it in all three positions and see which one is preferred.

### Boundary Compensation Control



Large room boundaries, such as floors, walls, and ceilings, reinforce sound by acting essentially as acoustic “mirrors.” When the speaker is mounted too close to the corner or a wall/ceiling intersection, this sonic “reinforcement” often results in an unnatural heaviness or coloration of the sound.

## Specifications

	IWCB-52	IWCB-525	IWCB-626
<b>Type</b>	2-way	2-way M-T-P array	2-way M-T-P array
<b>Drivers</b>	Woofer 5 ¼" (135mm) GLH* Pressure Driver Tweeter 1" (25mm) soft dome	5 ¼" (135mm) GLH* 5 ¼" (135mm) GLH* 1" (25mm) soft dome	6 ½" (165mm) GLH* 6 ½" (165mm) GLH* 1" (25mm) soft dome
<b>Frequency Response</b>	75Hz – 20kHz ±3dB	64Hz – 20kHz ±3dB	54Hz – 20kHz ±3dB
<b>Nominal Impedance</b>	6 Ohms	6 Ohms	6 Ohms
<b>Crossover Frequency</b>	2.75kHz, 3rd order	2.5kHz, 3rd order	2.2kHz, 3rd order
<b>Sensitivity</b>	87dB	87dB	87dB
<b>Recommended Power</b>	10 – 120 Watts RMS	10 – 140 Watts RMS	10 – 140 Watts RMS
<b>Dimensions</b> (W x H x D)	9 ⅝" x 17 ⅞" x 3 ⅞" 236 x 449 x 100mm	10 ⅜" x 19 x 3 ⅞" 274 x 484 x 100mm	12 ⅝" x 21 ⅝" x 3 ⅞" 312 x 547 x 100mm
<b>Cutout Dimensions</b> (W x H x D)	8 ⅞" x 16 ½" 206 x 411mm	9 ⅝" x 17 ⅞" 244 x 454mm	11 ⅞" x 20 ⅜" 283 x 518mm
<b>Net Weight</b>	9lbs; 4.1kg each	10lbs; 4.6kg each	12lbs; 5.6kg each

\*Graphite Loaded Homopolymer

Specifications are those in effect at the time of printing. Atlantic Technology reserves the right to change specifications or appearance at any time without notice.

Dolby Digital, 5.1, Dolby Stereo and Dolby Pro Logic are trademarks of Dolby Laboratories Licensing Corporation. DTS is a registered trademark of DTS Technology.

If it's necessary to mount the speaker closer than 12 inches to the ceiling or corner, you may find that by switching the Boundary Compensation control “on,” the speaker sounds better. We recommend that you try the control in both positions and see if it helps in your particular installation.

### Directional Vector Control™

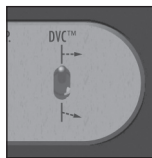

Oftentimes, it is visually advantageous to mount the speaker high up on the wall, as this puts the speaker above the field of vision and thus prevents any intrusion by the speaker into the room's décor.

However, acoustically, the best location for a speaker is at seated ear level, about 3-4 feet off the floor.

The DVC electronically directs the midrange sound at the listener's ears, even when the speaker is mounted high up on the wall.

The “on” position directs the sound down at the listeners when using the speakers as LCR theater speakers or primary stereo music speakers.

The “off” position fires the sound straight out from the speakers—above the listener's heads—which is perfect for non-localizable surround use, or for room-filling background music (“whole house audio”) use.

### IR Knockout



There's an IR “knockout” plug in the upper right corner of the front baffle. If you are using a multi-room control system, you can install a standard IR receiver in the knockout hole.

Should you have any questions or problems please feel free to contact us at 781-762-6300 or through our web site, [www.atlanticttechnology.com](http://www.atlanticttechnology.com).



343 Vanderbilt Avenue Norwood, MA 02062 (781) 762-6300 [www.atlantictechnology.com](http://www.atlantictechnology.com)