

# **Boston** *Bravo II*

High Performance Multi-Purpose Speaker

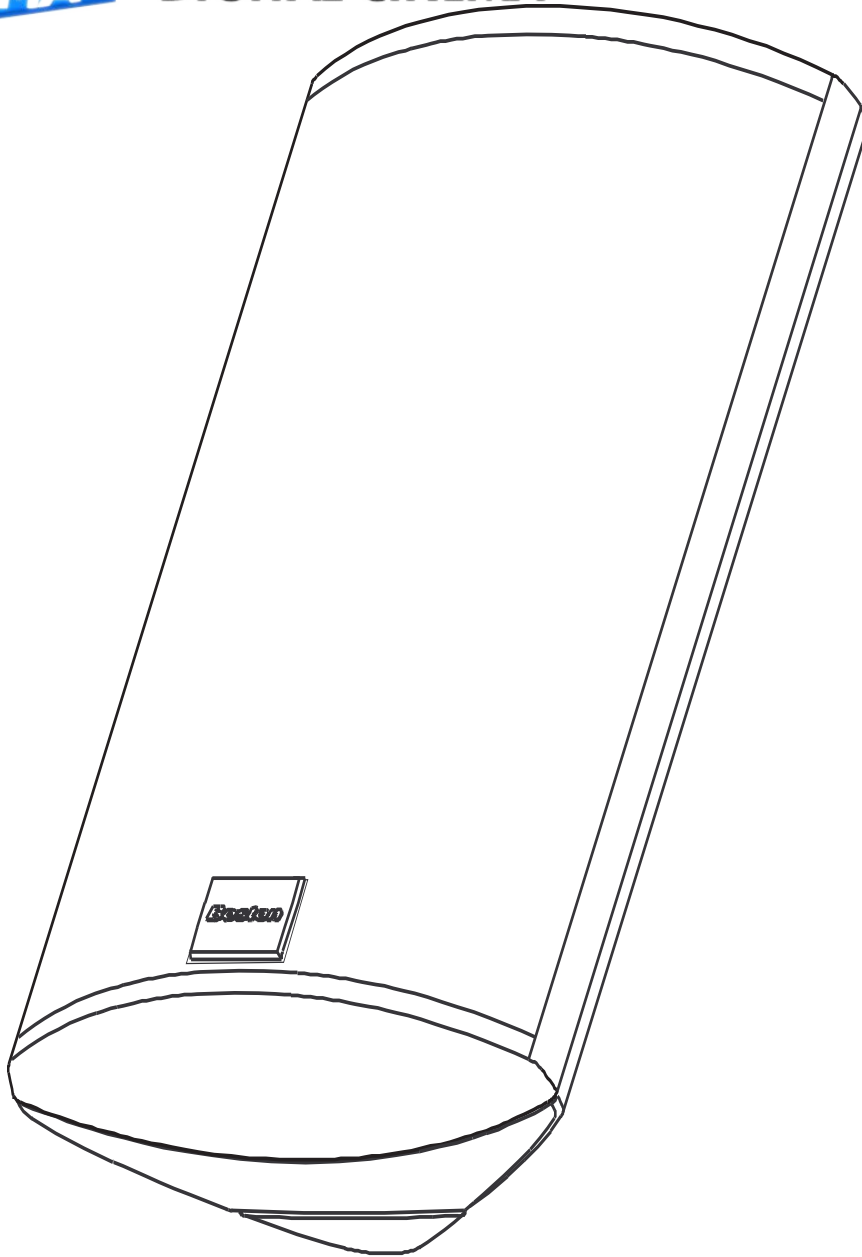

AVAILABLE AT  
DIGITAL CINEMA



**Boston**

*Boston Acoustics*

## Specifications

<b>Frequency Response (<math>\pm 3</math>dB)</b>	80Hz–20,000Hz
<b>Recommended Amplifier Power</b>	15–125 watts
<b>Nominal Impedance</b>	8 ohms
<b>Sensitivity [1 watt (2.83v) at 1m]</b>	89dB
<b>Bass Unit</b>	4½" (115mm) copolymer
<b>Tweeter</b>	1" (25mm) black anodized aluminum dome with AMD
<b>Crossover Frequency</b>	2500Hz
<b>Dimensions (HxWxD) with corner fillers</b>	14¼ x 6½ x 5¼" (362 x 166 x 134mm)
<b>Dimensions (HxWxD) without corner fillers</b>	14¼ x 6½ x 4¼" (362 x 166 x 108mm)
<b>Weight</b>	5 lbs (2.25kg)
<b>Finish</b>	White, black, or silver textured ABS with matching metal grille

## Description

The Boston Bravo™ II is a multi-purpose, high performance compact loudspeaker. The Bravo II, which uses Boston's patented one-inch aluminum dome VR® tweeter with AMD and a 4½-inch woofer, can be combined with its supplied mounting bracket or rear stand to be mounted or placed virtually anywhere in any room.

The Bravo II is essentially one-quarter of a cylinder, allowing it to be mounted vertically at any height in a corner, or horizontally at the top of a wall, where wall and ceiling meet. Attaching the Bravo II to any surface is as simple as mounting the bracket to the wall, removing the grille from the speaker, and then attaching the speaker to the bracket using the supplied screws. Once the grille is placed back on the speaker, the means of attachment becomes virtually invisible. Additionally, the Bravo II can be placed either horizontally or vertically on any flat surface, such as a table or a shelf. Horizontally, it can either angle upward by resting on its two corner fillers or sit untilted using the rear stand.

Because it is designed as a high-performance, general-purpose speaker, the Bravo II is suitable for any high-fidelity application where it is important that the speaker blends into its surroundings. The Bravo II is well suited for background and whole house music applications. The Bravo II's highly flexible mounting bracket allows it to be placed in a wide variety of locations, and to for the speaker to be angled for optimum sound quality and three-dimensional imaging. When a pair is placed vertically in the corners of a room, the Bravo II creates an unusually wide listening window, providing true stereo sound reproduction over a broad area.

For full-range applications, it is recommended that the Bravo II be used in conjunction with one of Boston's powered subwoofers. The Bravo II's low frequency limit is 80Hz, allowing for a great deal of placement flexibility for the subwoofer. The Bravo II's robust design allows it be used with full-range signals and amplifiers rated between 15 and 125 watts. Please note that the Bravo II is not magnetically shielded. Therefore, it should not be placed closer than 18 inches from a tube television. The Bravo II may be used safely near projection and plasma televisions.

Also available; The Boston Bravo II Center. The Bravo II Center is sonically matched to the Bravo II and features Magnaguard® magnetic shielding allowing for use on or near tube televisions without interference.

## How to Connect Your Speakers

Correctly wiring your speakers is important for achieving the best sound quality. Wiring should take just a few minutes, but it's important to do it carefully, since incorrect wiring (such as reversed connections) can result in a poor soundstage and poor bass.

We recommend 18-gauge wire or thicker for runs up to 15 feet (4.5m), and 16-gauge wire or thicker for longer runs. Separate the first few inches of the wire conductors. Strip off ½-inch (12mm) of insulation from the ends of each speaker wire to expose the two conductors and tightly twist the wire strands.

**WARNING:** To prevent electrical shock hazard, always switch off the amplifier or receiver when making connections to the speaker.

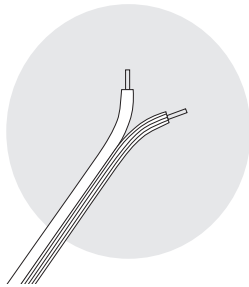

**IMPORTANT:** Typically, one side of the wire is smooth. Connect this side to the – (black) connection. The other side has a rib or stripe. Connect this to the + (red) connection.

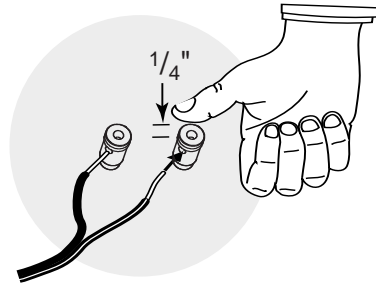

**Using the spring terminal posts:** The spring terminal posts permit easy connection to banana plugs, spade lugs, and bare wire.

Push the the top of the terminal down by approximately ¼-inch, exposing the hole. Insert the wire in the hole and release the terminal.

## Connecting the Boston Bravo to Your Amplifier or Receiver

1. Connect the speaker terminals to the amplifier speaker outputs.
2. Make sure the speaker cable is correctly routed through the mounting bracket.  
(see Mounting Options)
3. When making all connections, be sure to connect + to + (red) and – to – (black).
4. If using the Bravo II with a subwoofer, set the receiver's bass management to SMALL in the speaker setup menu. This will divert very low frequencies away from the center channel to the main speakers and/or subwoofer.

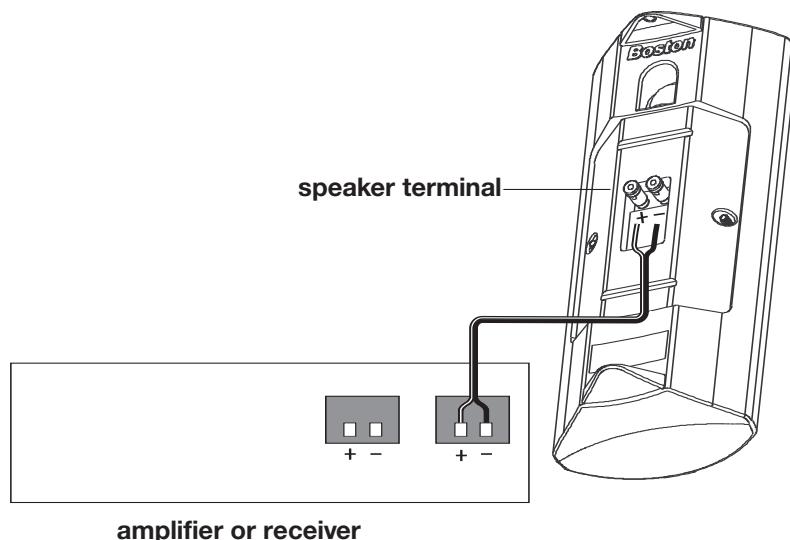

## Using the Bravo II on a Flat Surface

The Bravo II can be used on a flat surface, such as a table, shelf or the floor. For horizontal placement that angles up at 45°, both corner fillers must be used and the bracket must be removed. For untilted horizontal placement, the rear stand must be used *with the mounting bracket attached* (see “Mount the Speaker to the Bracket” and the “Rear Stand Installation Instructions” found on page 6. For vertical applications mount the four supplied rubber feet to the bottom of the speaker. Attach two of the supplied self-adhesive rubber feet so that its edge contacts the back edge of the cabinet. Apply two more self-adhesive rubber feet to the recesses at the front of the cabinet.

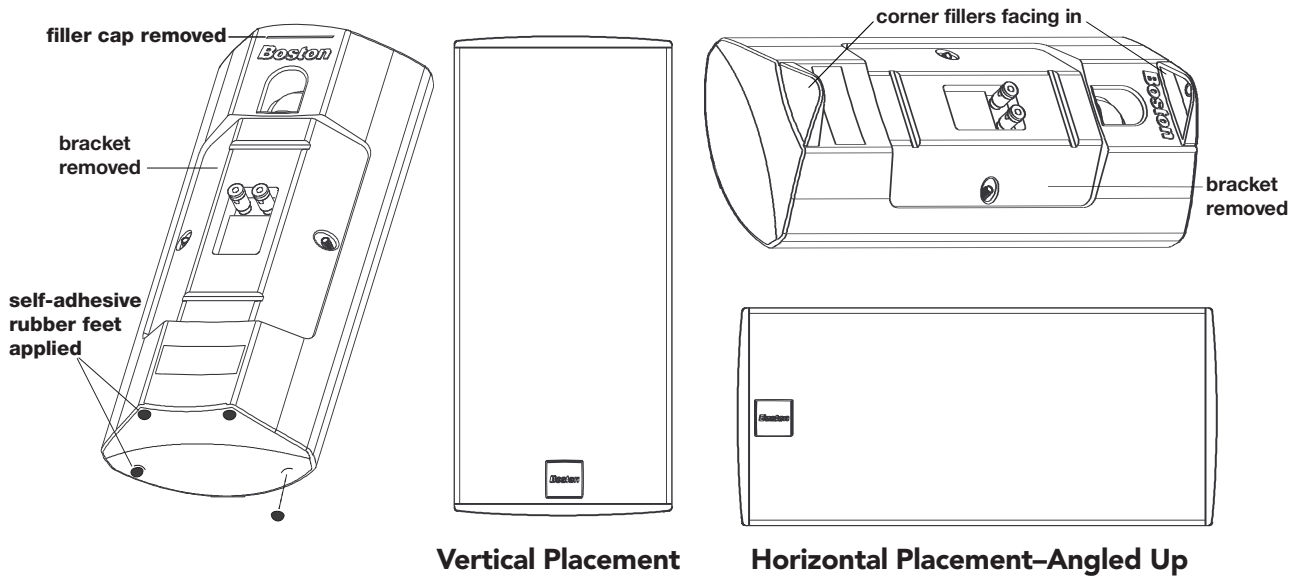

## Mounting the Bravo II

### Identify the Bracket

In its packing material, the Bravo II's mounting bracket is fitted into the back of the speaker. Remove the tape that is temporarily holding the bracket to the speaker, and then pull the bracket away from the back of the speaker. Determine how the Bravo II is to be mounted to the wall or ceiling. It can be mounted either horizontally or vertically, either on an open section of wall, or where two or three room surfaces meet. Refer to the illustration here to determine what screw holes on the Bravo II bracket should be used for your application.

**NOTE:** The large rectangular hole in the middle of the bracket will fit a single gang electrical outlet to route the speaker wire through a conduit.

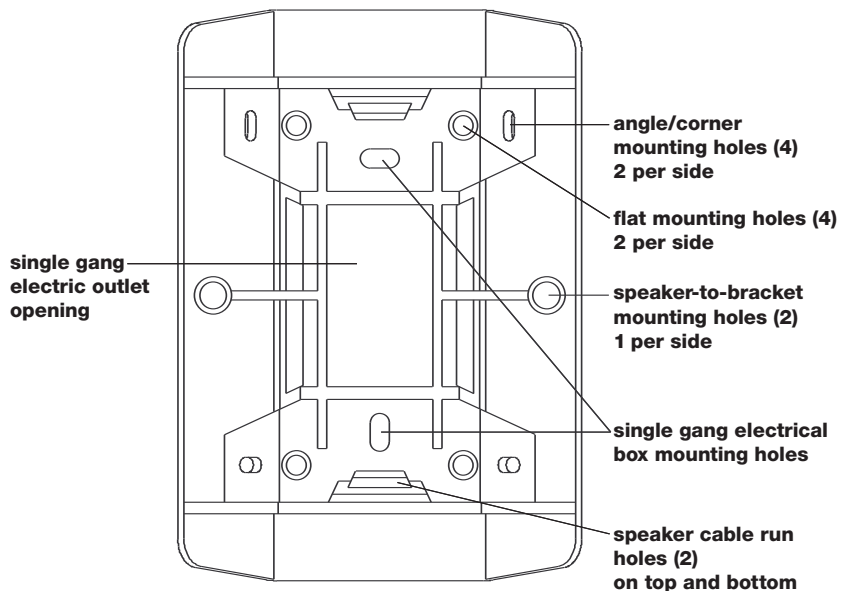

## Mount the Bracket to the Wall

Decide where to mount bracket.

**IMPORTANT:** See “Ceiling Clearance” on page 6.

Determine what mounting holes in the bracket will be used.

Mark the holes on the wall or ceiling using bracket as a template.

Drill the holes using the appropriate drill bit size to accommodate the mounting hardware that you plan to use (ie, 1/2-inch diameter to clear the toggle bolts for hollow surfaces or small enough to allow self-tapping screws in a solid surface).

Mount the bracket flat or into a corner as shown below. We recommend the use of four fasteners wherever possible. Consult a knowledgeable installer regarding the proper hardware to use on your wall.

Strip the speaker wires ends, and feed the speaker wire through the appropriate bracket opening.

Connect the wire to the speaker's terminals, taking care to maintain speaker polarity. (See “How to Connect Your Speakers” and “Basic Hookup” on page 3). Both the Bravo II and its bracket are symmetrical, so the speaker can be mounted with either its woofer or tweeter on top. In general, bass performance will be enhanced with the woofer as close to as many room surfaces as possible.

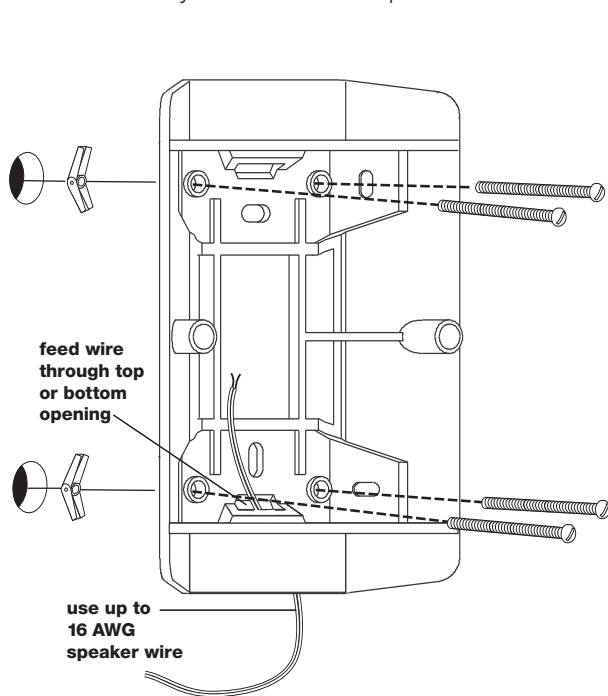

**Flat Mount Example**

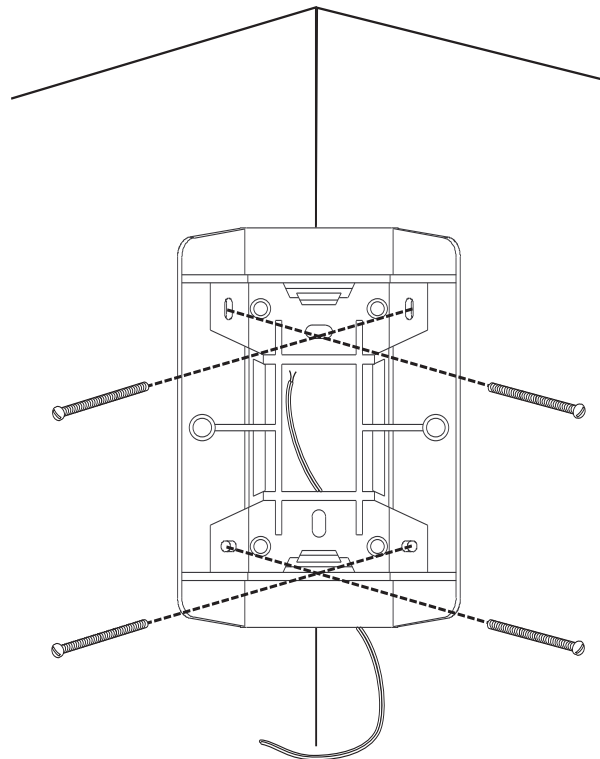

**Corner Mount Example**

## Corner Fillers

If the Bravo II is being mounted in a corner, then one or both of the supplied corner fillers may be inserted into the slots on the back of the speaker. These accessories will enhance the appearance of the installation by making it appear that the back of Bravo II extends into the corner.

**NOTE:** Up to 16-gauge speaker wire will fit between the fillers and the corner.

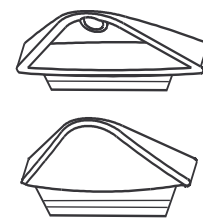

**corner filler (2)**

## Ceiling Clearance

If the Bravo II is to be mounted so that the top or the side of the speaker will meet a flush surface, either a wall (horizontally) or the ceiling (vertically), then measure the exact distance as shown here from that surface to the top or side of the bracket.

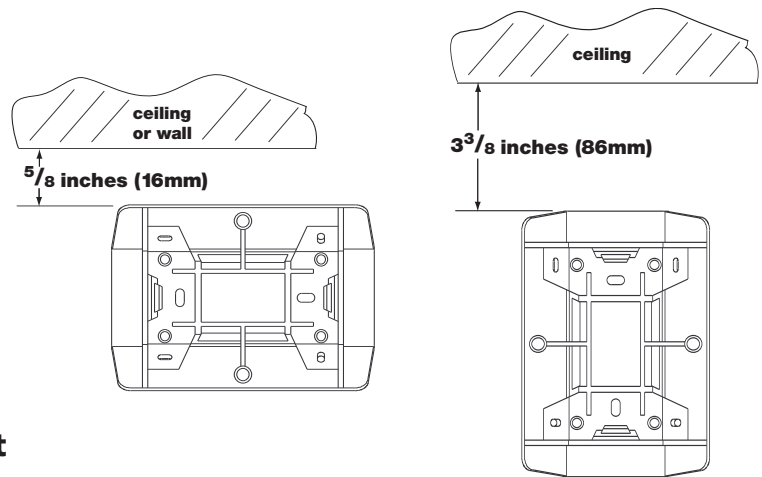

## Mount the Speaker to the Bracket

Remove the speaker's grille by grasping the back of the cabinet in one hand, while gently pulling the grille away with the other hand.

Align the openings in the back of the speaker with the two posts protruding from the bracket as shown below.

Gently remove any slack in the speaker wire as you push the speaker firmly onto the bracket.

Attach the speaker to the bracket by inserting the supplied screws through the holes in the front of the speaker and into the bracket as shown below (*do not over-tighten the screws*).

Replace the grille on the speaker.

**NOTE:** The Bravo II is not securely attached to its bracket unless the screws are used.

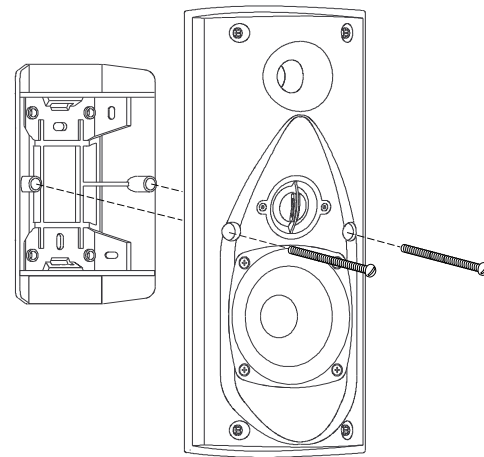

## Rear Stand Installation Instructions

The Boston Bravo can be used horizontally on an untilted flat surface, such as a table, shelf or the top of a rear projection TV using the included rear bracket stand.

First mount the speaker to the bracket (see above).

Next, place the speaker in the location that you intend to use it in (ie, correct grille/logo and tweeter/woofer orientation). Hold the stand in an upright position as indicated (note that the stand angles away from the bracket). Line up the stand with the lower slot in the bracket so that the 2 middle "fingers" are on either side of the web that bisects the slot. Slightly angle the stand away from the bracket and push the stand fingers up into the slot so that the 4 inner "fingers" are placed *inside* the slot and the 2 outer "thumbs" are placed *outside* the slot. Gently push the stand up into the bracket slot until the "fingers" and "thumbs" snap into place.

Attach the rubber feet to the stand and cabinet (detailed on page 4).

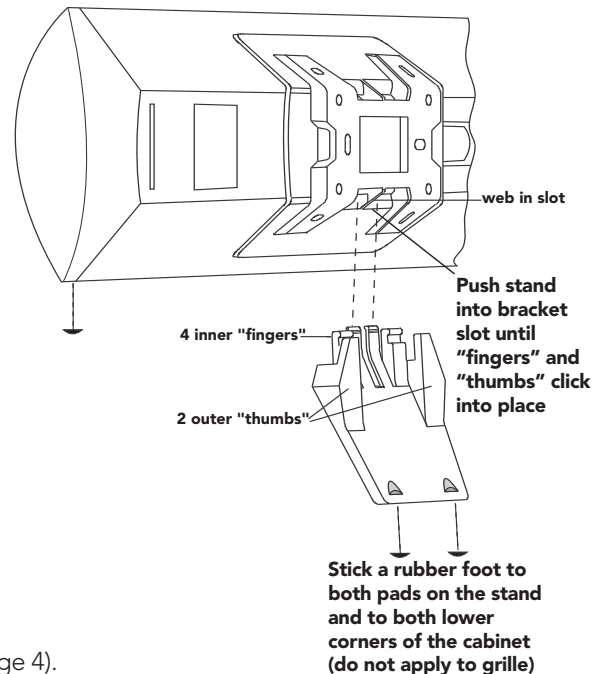

## Using the Bravo II as a Surround Speaker

Two Bravo IIs can be used as surround speakers for Dolby® Surround, Dolby® Pro Logic®, Dolby® Digital and DTS® surround sound formats. A third or fourth Bravo II can be added for use with Surround EX and DTS® ES surround sound formats. In general, best results will be obtained when the surround speakers are placed above ear level and either behind or beside the listening area. However, if attaching speakers to the wall is not an option, then the Bravo IIs can be placed horizontally directly on the floor. Since the low frequency limit of the Bravo II is approximately 80Hz, speaker bass management should be set to "small." This will redirect the surround channels' bass information to either the system's subwoofer or main speakers. Please consult your surround sound electronics owner's manual for additional information about speaker placement and bass management

## Using the Bravo II as a Main Speaker

The Bravo II can provide exceptional performance from 80Hz and above. For deep bass reproduction, a powered subwoofer might be a suitable addition to the Bravo II. In small or medium size rooms, two Bravo IIs should provide ample volume, given appropriate amplifier power of between 15 and 125 watts. In larger spaces, additional Bravo IIs may be necessary.

For broad, stereo coverage, vertical corner mounting of the Bravo II will produce excellent results. This technique will work especially well in situations where the distance between the two speakers is approximately 12 to 18 feet.

## Mounting Possibilities of the Bravo II

We designed the Bravo II to be mounted or placed in a wide variety of configurations. Shown below are seven of the most common possibilities for you to consider.

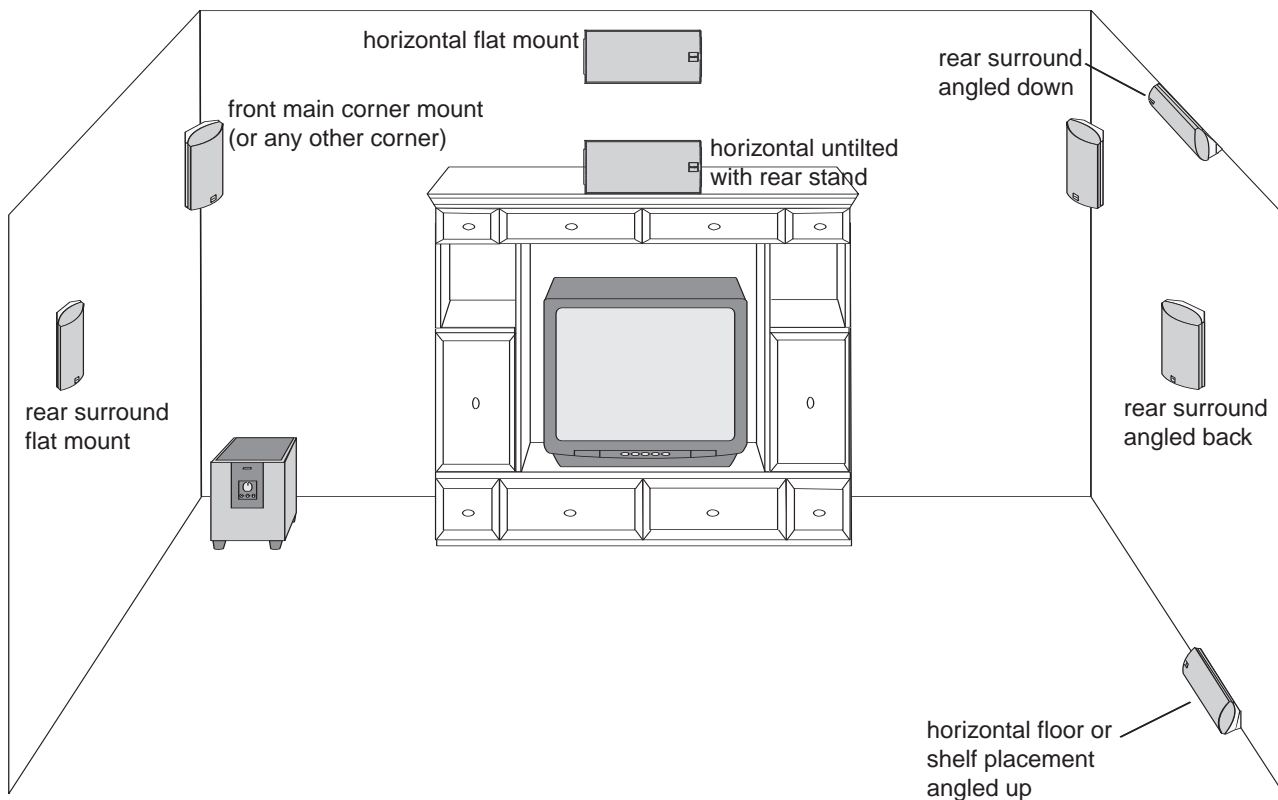

## Rotating the Logo for Horizontal Mounting or Placement

The logo plate on the Bravo II's grille can be rotated 90° in either direction to enhance the speaker's appearance when mounting or placing it in a horizontal position. To rotate the logo:

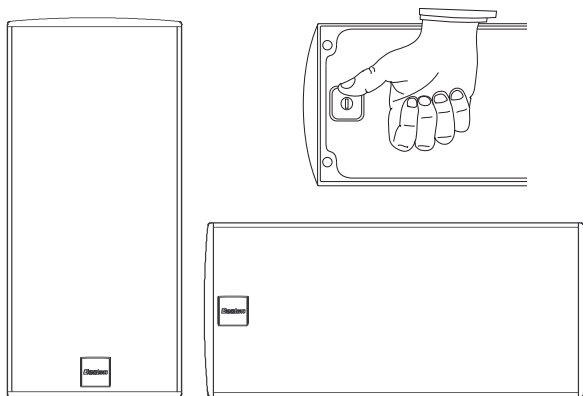

Remove the grille and turn it over.

Locate the logo's spring loaded post protruding through the bottom inside portion of the grille.

Place your thumb against the post and press firmly until the logo pops forward.

Rotate the logo to the desired position and release pressure on the post allowing it to snap back into the seated position.

## Listening Levels and Power Handling

The listed power recommendations in the Specifications section assume you will operate your system in a way that will not produce distortion. Even these rugged speakers can be damaged by a modest amplifier if it produces distortion. If you hear a harsh, gritty noise, turn down the volume. Prolonged or repeated operation of your speaker with a distorted signal from the amplifier can cause damage that is not covered by the warranty.

## If Service Seems Necessary

First, contact the dealer from whom you purchased the speakers. If that is not possible, write to:

Boston Acoustics, Inc. 300 Jubilee Drive Peabody, MA 01960 U.S.A.

We will promptly advise you of what action to take. If it is necessary to return your speaker to the factory, please ship it prepaid. After it has been repaired, we will return it freight prepaid in the U.S.A. and Canada.

***Boston***  
*Boston Acoustics*

300 Jubilee Drive  
Peabody, MA 01960 U.S.A.  
978.538.5000  
www.bostonacoustics.com

Dolby and Dolby Pro Logic are registered trademarks of Dolby Laboratories Licensing Corporation.

Boston Sound and AMD are trademarks and MagnaGuard, Boston, and Boston Acoustics, the Boston Acoustics Logo, and VR are registered trademarks of Boston Acoustics, Inc.

© 2004 Boston Acoustics, Inc. All rights reserved.

Specifications subject to change without notice.

042-002157-0