



*AVAILABLE AT
DIGITAL CINEMA*

702

S2





703

S2

704





S2

1. Unpacking

	1
	4
	4
	1

Carton Contents**Check in the carton for:**

- 1 Foam plug
- 1 Accessory pack containing
 - 4 Rubber feet
 - 4 M6 spike feet
 - 4 Lock nuts (10mm across flats)
- 1 Plinth
- 1 Accessory pack containing
 - 1 Allen key
 - 4 M6 x 35mm screws
 - 4 Plain washers
 - 4 Shakeproof washers

	1
	4
	4
	4

Environmental Information

This product complies with international directives, including but not limited to:

- i. the **R**estriction of **H**azardous **S**ubstances (RoHS) in electrical and electronic equipment,
- ii. the **R**egistration, **E**valuation, **A**uthorisation and restriction of **C**hemicals (REACH)
- iii. the disposal of **W**aste **E**lectrical and **E**lectronic **E**quipment (WEEE).

Consult your local waste disposal authority for guidance on how properly to recycle or dispose of this product.

2. Positioning

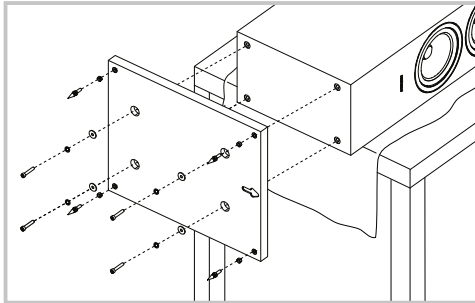

Speaker Installation

The speakers are intended to be floor mounted only. It is important to ensure that the speakers stand firmly on the floor using the spike feet supplied whenever possible. In addition, fit the plinth for proper stability.

You may attach the plinth during the unpacking process, following the diagrams on the top flap of the carton. Alternatively, you may attach it after the product has been fully unpacked, by covering a suitable support such as a table with a cloth and laying the speaker on its side with the base of the cabinet overhanging the support. Align the plinth with its attachment holes in the underside of the cabinet, ensuring that the arrow on the underside of the plinth points forwards. Secure the plinth using the screws and washers supplied. Fit the shakeproof washers between the plain washers and the screw heads. Tighten the screws using the Allen key supplied.

The spike feet are designed to pierce carpet and rest on the floor surface. Initially, screw the lock nuts onto the spikes enough to leave the nuts floating just above the carpet when the spikes are resting on the floor beneath. Screw the spikes fully into the threaded inserts in the plinth. If the cabinet rocks when placed on the floor, unscrew the two spikes that do not touch the floor until the cabinet rests firmly without rocking. Finally, lock the nuts against the cabinet. It may be more convenient to fit and adjust the spike feet after speaker positioning has been optimised.

If there is no carpet and you wish to avoid scratching the floor surface, use either a protective metal disc (a coin perhaps) between the spike and the floor, or use the supplied rubber feet. Fit the rubber feet and level the cabinet in the same manner as with the spike feet.

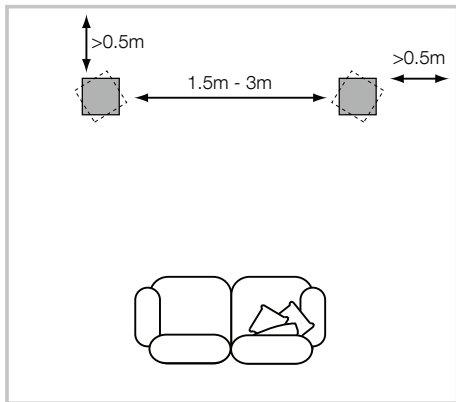

Speaker Positioning

Adjustment of speaker position following initial installation will probably further improve the sound quality and is usually worthwhile.

In either stereo or home theatre installations, try to ensure that the immediate surroundings of each speaker are similar in acoustic character. For example, if one speaker is adjacent to bare walls while the other is adjacent to soft furnishings and curtains, both the overall sound quality and the stereo image are likely to be compromised.

Conventional Stereo Systems

To begin with, the speakers should be positioned between 1.5m and 3m apart at two corners of an equilateral triangle completed by the listening area at the third corner. The speakers should be approximately 0.5m away from the back wall, and at least 0.5m away from any side walls (above).

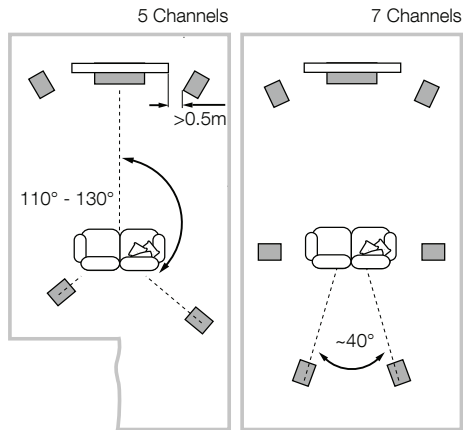

Home Theatre Systems

If the speakers are to be used for the front channels in a home theatre system, they should be placed closer together than for 2-channel audio, because the surround channels tend to widen the image. Positioning the speakers within approximately 0.5m of the sides of the screen will also help keep the sound image in scale with the visual image. As with conventional stereo positioning, the speakers should ideally be at least 0.5m away from any side walls. If you would prefer to place your speaker against the back wall and this location results in over emphasised bass, see the Fine Tuning section of this manual for information on using the foam plugs.

Stray magnetic fields

The speaker drive units create stray magnetic fields that extend beyond the boundaries of the cabinet. We recommend you keep magnetically sensitive articles (CRT television and computer screens, computer discs, audio and video tapes, swipe cards and the like) at least 0.5m from the speaker. LCD, OLED and plasma screens are not affected by magnetic fields.

3. Connections

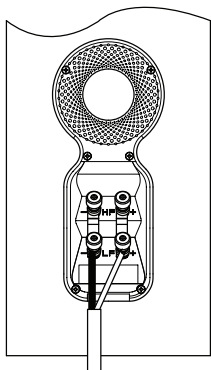

All connections should be made with the audio equipment switched off.

There are 2 linked pairs of terminals on the back of the speaker. For conventional connection (above left), the terminal links should remain in place (as delivered) and just one pair of terminals connected to the amplifier. For bi-wire connections or bi-amplification (above right), the terminal links should be removed and each pair of terminals connected to the amplifier or amplifiers independently. Bi-wiring can improve the resolution of low-level detail.

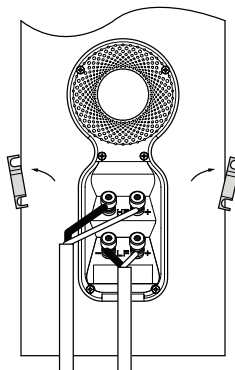

Ensure that the positive terminals on the speaker (marked + and coloured red) are connected to the positive output terminal on the amplifier and the negative terminals on the speaker (marked - and coloured black) are connected to the negative output terminal on the amplifier. Incorrect connection can result in poor imaging and loss of bass.

Ask your dealer for advice when selecting speaker cable.

4. Fine Tuning

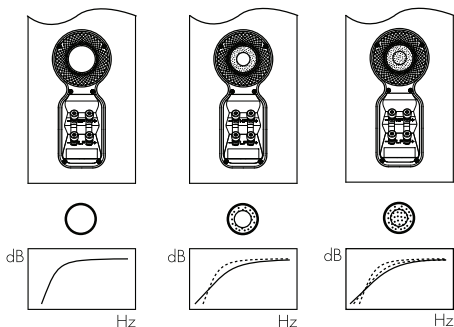

Before fine tuning, make sure that all the connections in the installation are correct and secure.

Moving the speakers further from the walls will generally reduce the volume of bass. Space behind the speakers will also help to create an aural impression of depth. Conversely, moving the speakers closer to the walls will increase the volume of bass. If you want to reduce the volume of bass without moving the speakers further from the wall, fit the foam plugs or, for less severe bass reduction, the foam rings in the port tubes (above).

If the bass seems uneven with frequency this will most probably be a consequence of the acoustic properties of your listening room. Even small changes in the position of the speakers or listening position can have a significant effect on sonic performance, especially at low frequencies. Try moving your listening position or locating your speakers along a different wall if possible.

If no alternatives exist, you can adjust your loudspeakers' low-frequency performance using the supplied foam bungs. The bungs are a two-piece part, allowing for a degree of fine-tuning using either the outer, larger-diameter piece in isolation or the two parts together. Using solely the outer, larger-diameter foam bung will deliver less bass attenuation than the complete bung assembly.

5. Running In

The performance of the speaker will change subtly during the initial listening period. If the speaker has been stored in a cold environment, the damping compounds and suspension materials of the drive units will take some time to recover their correct mechanical properties. The drive unit suspensions will also loosen up during the first hours of use. The time taken for the speaker to achieve its intended performance will vary depending on previous storage conditions and how it is used. As a guide, allow up to a week for the temperature effects to stabilise and 15 hours of average use for the mechanical parts to attain their intended design characteristics.

6. Aftercare

The cabinet surfaces will usually only require dusting. If you wish to use an aerosol or other cleaner, apply the cleaner onto the cloth, not directly onto the product and test a small area first, as some cleaning products may damage some of the surfaces. Avoid products that are abrasive, or contain acid, alkali or antibacterial agents. Marks on the paint surface may be removed with a dilute perfume-free soap solution. Remove any remaining streak marks by spraying with a proprietary glass cleaner and lightly wiping dry with a microfibre cloth. Do not use cleaning agents on the drive units and avoid touching them as damage may result.

Real wood veneers are treated with an ultra-violet resistant lacquer to minimise changes in colour over time. Nevertheless, like all natural materials, a degree of colour change is to be expected. Colour differences may be rectified by exposing all the veneer surfaces equally and evenly to sunlight until the colour is uniform. This process can take a long time, but may be accelerated by careful use of an ultra-violet lamp. Keep the speakers away from direct sources of heat such as radiators and warm air vents in order to minimise the possibility of the wood veneer cracking.