

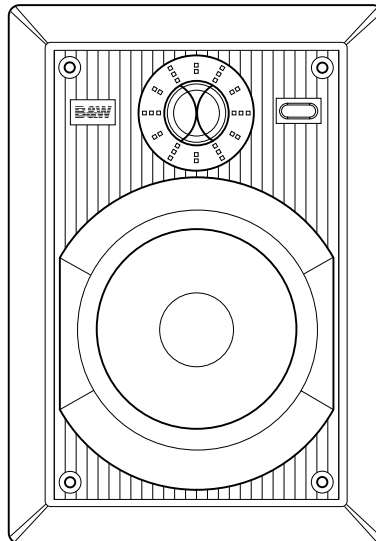

**AVAILABLE AT
DIGITAL CINEMA**

Custom Installation Series

CWM™ 500, CWM™ 650, CWM™ 800 Owner's manual



L I S T E N A N D Y O U ' L L S E E

Figure 1

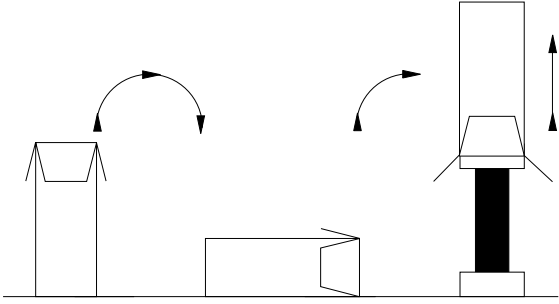

Figure 2

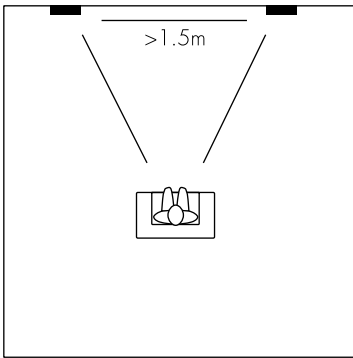
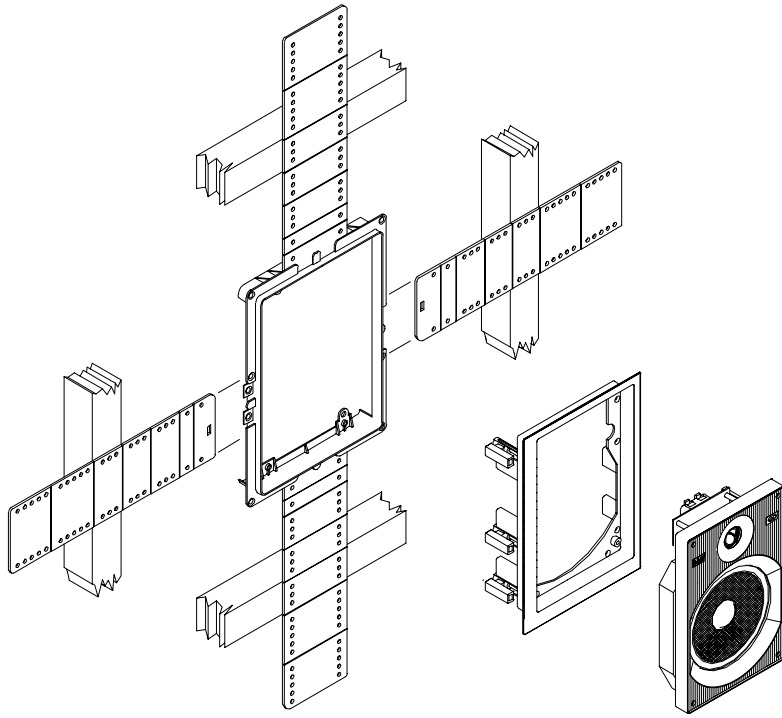

Figure 3



Owner's manual
CWM™500
CWM™650
CWM™800

English	1
Français	2
Deutsch	4
Español	5
Português	7
Italiano	9
Nederlands	11
Ελληνικά	12
Русский	14

Figure 4

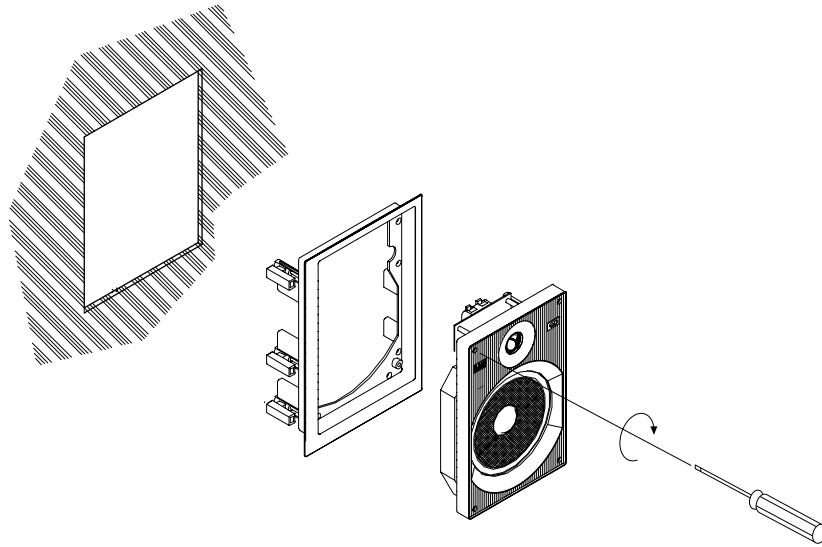

INTRODUCTION

Thank you for purchasing B&W Custom Wall Mount (CWM™) speakers.

Since its foundation in 1966, the continuing philosophy of B&W has been the quest for perfect sound reproduction. Inspired by the company's founder, the late John Bowers, this quest has entailed not only high investment in audio technology and innovation but also an abiding appreciation of music to ensure that the technology is put to maximum effect.

It is also our policy to make sure the advanced features pioneered on one product are incorporated into others we manufacture. The CWM™ range incorporates woven Kevlar® cone mid/bass drive units for lowest coloration and maximum definition.

However, no matter how good the speakers themselves, they must work well into the listening room and time spent on planning the installation will reap the reward of many hours listening pleasure. Please read through this manual fully. It will help you optimise the performance of the system.

B&W distribute to over 50 countries worldwide and maintain a network of dedicated distributors who will be able to help should you have any problems your dealer cannot resolve.

UNPACKING

(figure 1)

- Fold the top carton flaps right back and invert the carton and contents.
- Lift the carton clear of the contents.
- Remove the inner packing from the product.

Check the contents:

- 2x Baffle with drive units, crossover and foam
- 2x Wall frame with swing out dogs
- 2x Loudspeaker grille
- 1x Alignment template
- 1x Accessory pack containing:

8x Self-Tapping screws (for frame to PMK fixing) Not for CWM™500

8x Machine screws (fixing baffles to wall frames)

We suggest you retain the packaging for future use. Remove the grilles and baffles (Not for CWM™500) from the wall frames and, to avoid damage, keep them in their plastic bags (and preferably in the carton) away from the work area until you are ready to fit them.

POSITIONING – NEW CONSTRUCTION VERSUS RETROFIT

Check that there is no conflict with other in-wall installations (pipe work, air conditioning, power-cabling etc.). In existing construction, use a stud-finding tool to map the wall construction accurately and a pipe detector to scan the proposed installation position. Avoid installing the speakers in the same cavity of the wall as flimsy ducting, which may be induced to rattle.

The speakers are designed to operate satisfactorily in a wide range of cavity volumes, ideally above 15 litres (0.5 cu ft).

The speakers are balanced for half-space mounting (i.e. flush in a wall or soffit). Placement near a wall/ceiling, wall/floor junction or in a corner is to be avoided as it may give rise to too much bass and a boomy quality to the sound. If possible, keep the speakers more than 0.5m (20in) from the wall edges.

The speakers may be mounted in either portrait or landscape orientation. Wherever possible, however, portrait orientation, with the drive units mounted one above the other, is to be preferred as it gives better horizontal dispersion and a more stable stereo image. If landscape orientation is used, orient the baffle so that the tweeters are towards the centre of the room. Do not mix portrait and landscape at left and right, as an imprecise stereo image will be created.

The following sections give guidance on optimum positioning, but this may be modified in line with domestic constraints.

Normal Stereo and Home Theatre Front Left and Right Applications

(figure 2)

The speakers should be positioned with the tweeters at a little above ear height. If the speakers are to be used low in the wall invert the speaker so the bass unit is uppermost. The spacing between them will depend on the size of the room and distance to the listeners. As a general rule they should not be closer to the listener than 1.5m (5ft) and the distance between them should not exceed their distance from the listeners. Having the speakers and listeners approximately at the corners of an equilateral triangle is not a bad rule to follow. This arrangement generally provides the best stereo imaging. If the speakers are placed too far apart, a hole-in-the-middle effect may become apparent. Too close and the panoramic effect will be lost, accompanied by a reduction in depth information.

For Home Theatre Installations, the speakers should not be closer together than the width of the screen and their height should be approximately at centre screen height.

Home Theatre Centre Channel Applications

Theoretically, the best position for a centre channel speaker is behind the centre of the screen, but this can only be realised when using an acoustically transparent projection screen. In most cases the speaker will be positioned in a laterally central position either directly above or directly below the screen. All other things being equal, choose the position that is nearest ear height. However, if this leads to a below screen position, you should be careful to ensure that the speaker is not too close to the floor (see above) and that the sound will not be muffled by the later placement of furniture. See also the comments on baffle orientation in the preceding section.

Home Theatre Surround Speaker Applications

The sound from surround speakers should be as diffuse as possible. This ensures that the frontal audio image is not distorted by changes of listener position or head movements. The speakers should generally be placed behind and 0.6m (2ft) or more above ear height. Ceiling mounting often gives good results in this application. The orientation is less important in this application than in other cases.

WARNING: The CWM™ speakers produce a static magnetic field that extends outside the cabinet boundary. As such they should not be placed within 0.5m (20in) of equipment that may be affected by such a field, e.g. Cathode Ray Tubes in TVs and Personal Computers.

DAMPING THE WALL CAVITY

A foam pad is supplied to damp the area behind the drive units. In addition, loosely fill the whole section of the wall cavity with wadding. Fibreglass and mineral wool matting supplied for heat insulation are suitable, but not closed cell foam or expanded polystyrene. Check that there is no debris that may fall into the speaker (especially in ceiling mount situations).

IMPORTANT: YOU SHOULD CHECK THAT THE MATERIALS YOU USE MEET THE LOCAL FIRE AND BUILDING REGULATIONS.

FITTING THE WALL FRAME

New Construction

(figure 3)

Fit the separately available pre-mount kit – (PMK500 for CWM™500, PMK650 for CWM™650, PMK800 for CWM™800) to the studding before the drywall panels are fitted, following the instructions supplied with the kit. The drywall panels should be fitted up to the pre-mount frame and plastered over.

Screw, but do not tighten, 4 of the screws provided through the slots in the wall frame into the pilot holes in the pre-mount frame. (The CWM™500 does not attach to the pre-mount frame directly, but uses the clamping dogs described below).

Existing Construction

(figure 4)

Push out the slots in the template provided. Position the template on the wall as required. Mark along the inside edges of the slots and cut out the aperture neatly.

Position the frame in the wall and screw in the 6 (or 4 for CWM™500, where the baffle/frame is fitted as one assembly) screws visible from the front of the frame. These screws swing out clamping dogs that locate behind the drywall. Ensure that they have located properly and loosely tighten the screws.

Existing construction Method 2

Using the pre-mount frame in retrofit situations requires that the aperture is cut fairly accurately. Use the template provided to mark out the correct size aperture, having regard to how the wall frame is to be lined up with any features such as door frames, and cut out the aperture neatly. Feed the pre-mount frame through the aperture and pull it forward so that it sits flat on the rear of the drywall and the inner part of the frame protrudes through the aperture. Screw, but do not tighten, 4 of the screws provided through the slots in the wall frame into the pilot holes in the pre-mount frame.

All Methods

Align the frame squarely and tighten down the screws. A certain amount of flexing of the wall frame is allowed to take up unevenness in the wall surface, but do not over tighten the screws as excessive distortion of the frame may impede the fitting of the baffle.

Installing an IR Sensor

A pilot hole is provided on the rear of the baffle (looking at the rear, it is to the left of the tweeter). Use a 1/2" drill bit and drill through the baffle from the rear. Mount the IR sensor following the manufacturer's instructions.

CUSTOMISING

The wall frame has a white semi-matte paintable finish, ready if necessary to be re-finished to match your own decor. Decorate before the baffle is fitted.

Do not paint the baffle. Remove it before re-decoration (CWM™500 includes a paint mask). Avoid touching the drive units, as damage may result.

FITTING THE BAFFLE AND CONNECTIONS

The baffle is secured to the wall frame by 4 machine screws in the corners (comes as one assembly with the frame for the CWM™500). All connections should be made with the equipment switched off.

The terminals accept bare wires. Connect the red (+ve) terminal to the positive terminal of the amplifier and the black (-ve) to the negative. Failure to observe correct polarity will result in ill-defined panning of sounds and strange phase effects.

When choosing cable, keep the total electrical impedance (out and back) below the maximum recommended in the specification. Ask your dealer for advice, as the optimum cable will depend on the length required. Cut off excess length and tie down loose cable to prevent rattles.

HF Controls

The switch on the front baffle provides a boost or cut in the speaker's high-frequency output. Use it to adjust the high-frequency level to compensate for severely off axis positioned speakers or heavy wall coverings (Boost) or speakers positioned in highly sound reflective rooms (Cut).

FRANÇAIS

INTRODUCTION

Nous vous remercions d'avoir choisi les enceintes encastrables B&W de la série Custom In Wall Mount (CWM™).

Depuis sa fondation en 1966, la philosophie de B&W a toujours été la quête de la reproduction sonore la plus parfaite qui soit. Inspirée par son fondateur, le regretté John Bowers, cette recherche a entraîné de très lourds investissements en équipements et en innovations mais elle nous a surtout conduits à acquérir une connaissance très approfondie de la musique afin que la technologie soit toujours utilisée de façon optimale.

Notre politique est d'introduire dans le maximum de nos réalisations et aussi souvent que cela est possible, les technologies avancées qui ont été développées sur l'une de nos productions. La série CWM™ adopte le haut-parleur de grave-médium à membrane en Kevlar® tressé qui réduit les colorations et apporte un maximum de définition.

Au delà des qualités propres aux enceintes elles-mêmes, vous ne devez pas oublier qu'elles doivent fournir les meilleurs résultats en association avec la salle d'écoute. Afin de tirer le meilleur parti de la qualité de vos enceintes, vous devez savoir que l'étude de leur installation joue un grand rôle dans le résultat d'écoute général. Le soin que vous consacrerez à leur mise en œuvre sera récompensé par de très nombreuses heures d'écoute et de plaisir musical. Nous vous invitons à lire intégralement ce manuel. Il vous aidera à optimiser les performances du système.

B&W qui est distribué dans plus de 50 pays, maintient un réseau de distributeurs officiels capables de vous aider si vous rencontrez un problème que votre revendeur ne saurait résoudre ; n'hésitez pas à les contacter en cas de besoin.

DEBALLAGE

(figure 1)

- Ouvrez et rabattez la partie supérieure de l'emballage ; retournez l'ensemble avec son contenu.
- Soulevez le carton pour le vider de son contenu.
- Enlevez les éléments qui protègent l'appareil.

Vérifiez le contenu :

- 2 x baffle comportant les haut-parleurs, le filtre et de la mousse
- 2 x cadre de fixation murale avec oreilles rétractables de maintien
- 2 x grille de protection des haut-parleurs
- 1 x gabarit d'alignement
- 1 x sachet d'accessoires contenant :

8 x vis auto perforantes
(pour fixation du PMK à l'ossature) sauf pour le CWM™500

8 x vis mécaniques pour la fixation du baffle sur le cadre mural

Nous vous suggérons de conserver l'emballage pour un usage ultérieur. Veuillez retirer les grilles et les baffles (sauf pour le CWM™500) du cadre mural et conservez-les à l'abri dans leur sac en plastique voire même dans leur carton, loin de la zone de travail pour qu'ils ne courent aucun risque d'endommagement.

MISE EN PLACE – NOUVELLE CONSTRUCTION OU RENOVATION

Vérifiez qu'il n'existe aucun risque de conflit avec d'autres éléments encastrés dans la cloison (conduite, air conditionné, câble électrique etc.). Dans le cas d'une construction existante, il est préférable de dresser une carte précise des réseaux encastrés. Evitez d'installer les haut-parleurs dans une cavité comportant une canalisation ou ayant une paroi mince ou fragile qui risqueraient de résonner ou de vibrer. Ces enceintes sont conçues pour fonctionner de manière satisfaisante dans une large gamme de volumes de charge, idéalement supérieurs à 15 litres.

L'équilibre des enceintes est ajusté pour fournir la meilleure linéarité dans un demi espace de rayonnement (encastrées dans un large plan). Il est donc préférable d'éviter l'encastrement à proximité de la jonction entre un mur et le plafond ou près d'un angle de mur qui occasionneront une exagération des fréquences basses risquant d'altérer la fidélité de reproduction. Eloignez, si vous le pouvez, les haut-parleurs de plus de 0,5 m des angles de la pièce.

Les enceintes peuvent être installées verticalement ou horizontalement. Préférez, si possible, la position verticale. Lorsque les haut-parleurs sont placés l'un au-dessus de l'autre, ils procurent une meilleure directivité horizontale, favorable à la création d'une image stéréophonique stable. Si vous êtes amenés à installer vos enceintes horizontalement, orientez les tweeters vers le centre. N'installez jamais une enceinte verticalement tandis que l'autre est en position horizontale ; vous obtiendriez une image stéréophonique tout à fait imprécise.

Les paragraphes suivants comprennent de nombreux conseils permettant de parvenir au positionnement optimal mais ils peuvent être adaptés à vos contraintes domestiques.

Utilisation normale en stéréophonie ou en enceintes gauche et droite pour Home Cinema

(figure 2)

Les enceintes seront positionnées, le tweeter placé très légèrement au dessus de la hauteur des oreilles de l'auditeur. Au cas où les enceintes seraient installées dans la partie inférieure du mur, nous vous recommandons de les inverser, le haut-parleur de grave se retrouvant en haut. L'écartement des enceintes dépend des dimensions de la salle et de la distance d'écoute. En règle générale, elle ne doivent pas se trouver à moins d'un mètre cinquante de l'auditeur et leur écartement ne doit pas être supérieure à celui qui les sépare de la position d'écoute. Placer les deux enceintes et l'auditeur aux trois sommets d'un triangle équilatéral n'est

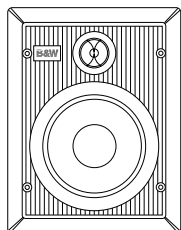
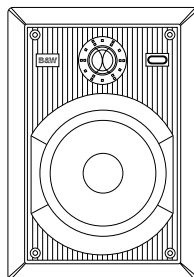
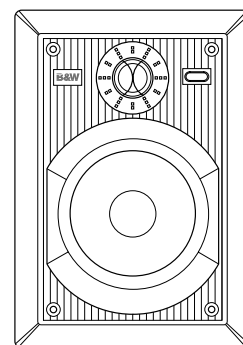
**CWM™500****CWM™650****CWM™800**

Drive units	1x 125mm (5in) Kevlar® mid/bass1x 25mm (1in) high-frequency	1x 165mm (6 1/2in) Kevlar® mid/bass1x 25mm (1in) metal dome high-frequency	1x 200mm (8in) Kevlar® mid/bass1x 25mm (1in) metal dome high-frequency
Frequency response	55Hz – 20kHz ±3dB	50Hz – 20kHz ±3dB	40Hz – 20kHz ±3dB
Sensitivity	88dB spl (2.83V, 1m)	89dB spl (2.83V, 1m)	90dB spl (2.83V, 1m)
Nominal impedance	8Ω	8Ω	8Ω
Crossover frequency	3.5kHz	3.5kHz	3.5kHz
Recommended amplifier power	20W–100W continuous into 8Ω on unclipped programme.	20W–130W continuous into 8Ω on unclipped programme.	20W–150W continuous into 8Ω on unclipped programme.
Protection	Auto-Reset Polyswitch	Auto-Reset Polyswitch	Auto-Reset Polyswitch
Frame size	Height: 228mm (9in) Width: 175mm (6 7/8in)	Height: 309mm (12 1/8in) Width: 216mm (8 1/2in)	Height: 371mm (14 5/8in) Width: 255mm (10in)
Cut-out size without pre-mount frame	Height: 212mm (8 3/8in) Width: 156mm (6 1/8in)	Height: 281mm (11in) Width: 186mm (7 3/8in)	Height: 337mm (13 1/4in) Width: 220mm (8 5/8in)
Cut-out size with pre-mount frame	Height: 217mm (8 1/2in) Width: 161mm (6 3/8in)	Height: 289mm (11 3/8in) Width: 193mm (7 5/8in)	Height: 343mm (13 1/2in) Width: 226mm (8 7/8in)
Min depth required	85mm (3 3/8in) from wall surface	85mm (3 3/8in) from wall surface	95mm (3 3/4in) from wall surface
Finishes	Semi-matt white suitable for customising or pre-painting	Semi-matt white suitable for customising or pre-painting	Semi-matt white suitable for customising or pre-painting
Pre-mount frame (optional)	PMK™500	PMK™650	PMK™800

**LISTEN AND YOU'LL SEE**

Kevlar is a registered trademark of DuPont.

B&W Loudspeakers Ltd. reserves the right to amend details of the specification without notice in line with technical developments.

Copyright © B&W Loudspeakers Ltd. Printed in England.

B&W Loudspeakers Ltd, Meadow Road, Worthing, BN11 2RX Tel: +44 (0) 1903 524801 Fax: +44 (0) 1903 524725
 B&W Loudspeakers of America, 54 Concord Street, North Reading, MA 01864-2699, USA Tel: (1978) 664 2870 Fax: (1978) 664 4109
<http://www.bwspeakers.com>