





**AVAILABLE AT
DIGITAL CINEMA**

HTM71 S2

HTM72 S2

1. Unpacking

HTM72 S2

	1
	4



Carton Contents**HTM72 S2****Check in the carton for:**

- 1 Foam plug
- 4 Self-adhesive rubber supporting feet

HTM71 S2**Check in the carton for:**

- 2 Foam plug
- 4 Self-adhesive rubber supporting feet

HTM71 S2

	2
	4

Environmental Information

This product complies with international directives, including but not limited to:

- i. the **R**estriction of **H**azardous **S**ubstances (RoHS) in electrical and electronic equipment,
- ii. the **R**egistration, **E**valuation, **A**uthorisation and restriction of **C**hemicals (REACH)
- iii. the disposal of **W**aste **E**lectrical and **E**lectronic **E**quipment (WEEE).

Consult your local waste disposal authority for guidance on how properly to recycle or dispose of this product.

2. Positioning

Speaker Installation

If using a projector with an acoustically transparent screen, place the speaker behind the centre of the screen. Otherwise position it directly above or below the screen, whichever is closest to ear level. Align the front of the speaker approximately level with the screen. The speaker is best used mounted on a rigid shelf or wall bracket or on a rigid floor stand. If the speaker is to be placed either on a shelf or in a rack shared with other AV equipment fix the 4 self-adhesive pads to the base of the speaker. They provide a degree of vibration isolation.

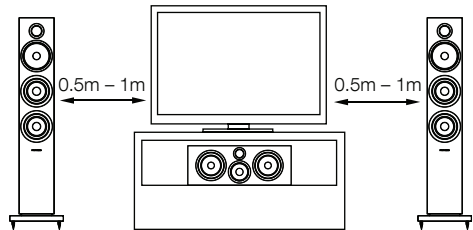

Stray magnetic fields

The speaker drive units create stray magnetic fields that extend beyond the boundaries of the cabinet. We recommend you keep magnetically sensitive articles (CRT television and computer screens, computer discs, audio and video tapes, swipe cards and the like) at least 0.5m from the speaker. LCD, OLED and plasma screens are not affected by magnetic fields.

3. Connections

HTM72 S2

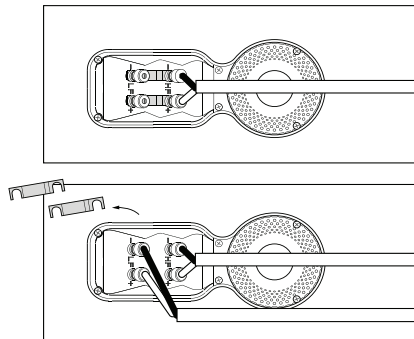

All connections should be made with the audio equipment switched off.

There are 2 linked pairs of terminals on the back of the speaker. For conventional connection (above left), the terminal links should remain in place (as delivered) and just one pair of terminals connected to the amplifier. For bi-wire connections or bi-amplification (above right), the terminal links should be removed and each pair of terminals connected to the amplifier or amplifiers independently. Bi-wiring can improve the resolution of low-level detail.

HTM71 S2

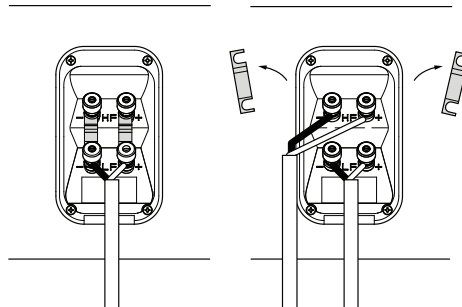

Ensure that the positive terminals on the speaker (marked + and coloured red) are connected to the positive output terminal on the amplifier and the negative terminals on the speaker (marked - and coloured black) are connected to the negative output terminal on the amplifier. Incorrect connection can result in poor imaging and loss of bass.

Ask your dealer for advice when selecting speaker cable.

4. Fine Tuning

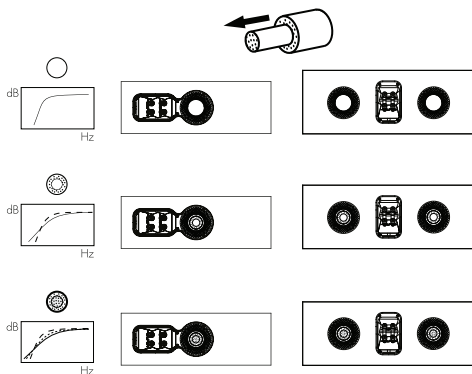

Before fine tuning, make sure that all the connections in the installation are correct and secure.

Moving the speakers further from the walls will generally reduce the volume of bass. Space behind the speakers will also help to create an aural impression of depth. Conversely, moving the speakers closer to the walls will increase the volume of bass. If you want to reduce the volume of bass without moving the speakers further from the wall, fit the foam plugs or, for less severe bass reduction, the foam rings in the port tubes (above).

If the bass seems uneven with frequency this will most probably be a consequence of the acoustic properties of your listening room. Even small changes in the position of the speakers or listening position can have a significant effect on sonic performance, especially at low frequencies. Try moving your listening position or locating your speakers along a different wall if possible.

If no alternatives exist, you can adjust your loudspeakers' low-frequency performance using the supplied foam bungs. The bungs are a two-piece part, allowing for a degree of fine-tuning using either the outer, larger-diameter piece in isolation or the two parts together. Using solely the outer, larger-diameter foam bung will deliver less bass attenuation than the complete bung assembly.

5. Running In

The performance of the speaker will change subtly during the initial listening period. If the speaker has been stored in a cold environment, the damping compounds and suspension materials of the drive units will take some time to recover their correct mechanical properties. The drive unit suspensions will also loosen up during the first hours of use. The time taken for the speaker to achieve its intended performance will vary depending on previous storage conditions and how it is used. As a guide, allow up to a week for the temperature effects to stabilise and 15 hours of average use for the mechanical parts to attain their intended design characteristics.

6. Aftercare

The cabinet surfaces will usually only require dusting. If you wish to use an aerosol or other cleaner, apply the cleaner onto the cloth, not directly onto the product and test a small area first, as some cleaning products may damage some of the surfaces. Avoid products that are abrasive, or contain acid, alkali or antibacterial agents. Marks on the paint surface may be removed with a dilute perfume-free soap solution. Remove any remaining streak marks by spraying with a proprietary glass cleaner and lightly wiping dry with a microfibre cloth. Do not use cleaning agents on the drive units and avoid touching them as damage may result.

Real wood veneers are treated with an ultra-violet resistant lacquer to minimise changes in colour over time. Nevertheless, like all natural materials, a degree of colour change is to be expected. Colour differences may be rectified by exposing all the veneer surfaces equally and evenly to sunlight until the colour is uniform. This process can take a long time, but may be accelerated by careful use of an ultra-violet lamp. Keep the speakers away from direct sources of heat such as radiators and warm air vents in order to minimise the possibility of the wood veneer cracking.

Bowers & Wilkins

B&W Group Ltd
Dale Road
Worthing West Sussex
BN11 2BH England

T +44 (0) 1903 221 800
F +44 (0) 1903 221 801
info@bwgroup.com
www.bowers-wilkins.com

B&W Group (UK Sales)
T +44 (0) 1903 221 500
E uksales@bwgroup.com

B&W Group North America
T +1 978 664 2870
E marketing@bwgroupusa.com

B&W Group Asia Ltd
T +852 3 472 9300
E info@bwgroup.hk

Copyright © B&W Group Ltd. E&OE
Printed in China