

Bowers & Wilkins



**AVAILABLE AT
DIGITAL CINEMA**

FPM Series

FPM2

FPM4

FPM5

FPM6

Owner's Manual

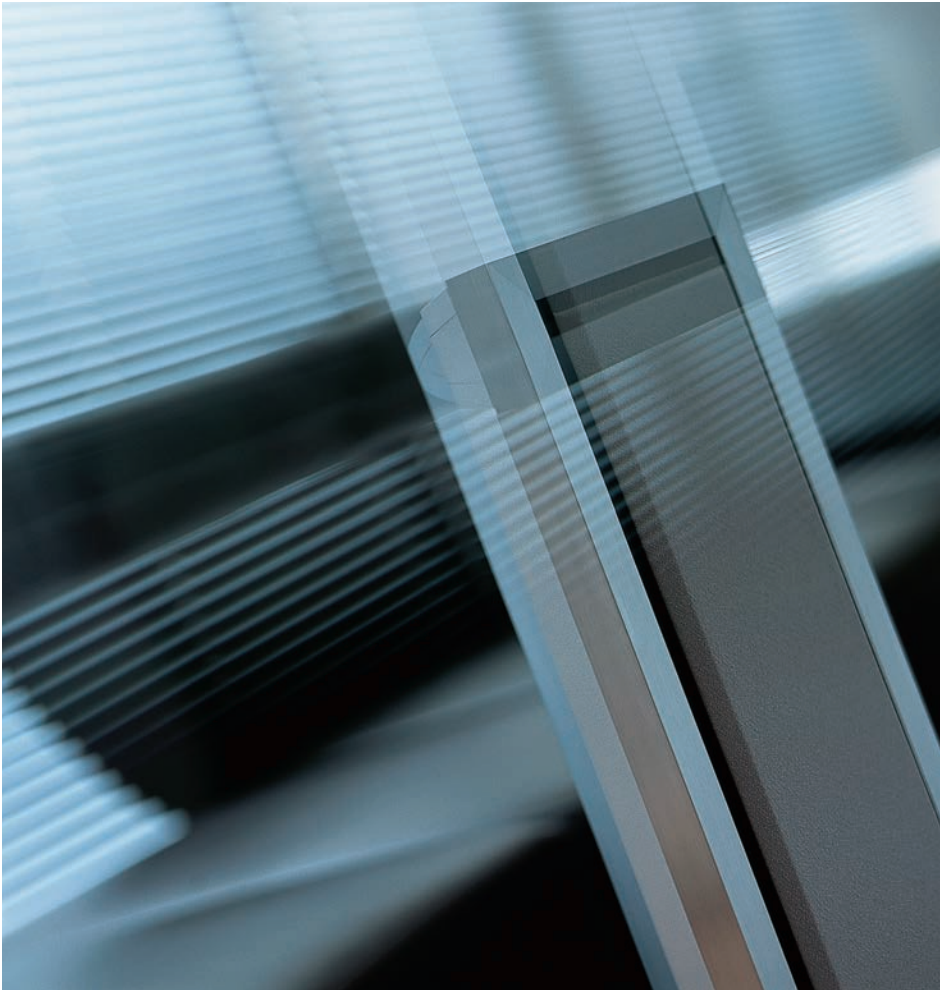

Figure 1

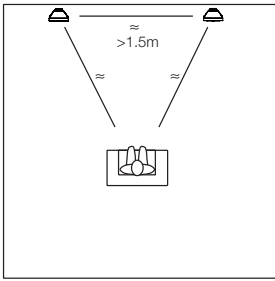

Figure 2

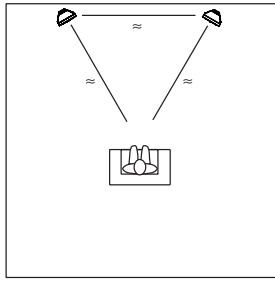

Figure 3

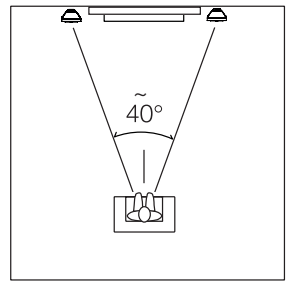

Figure 4

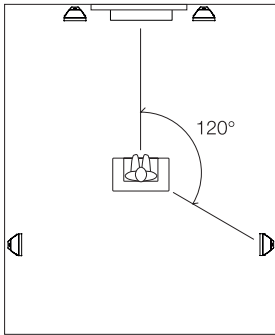

Figure 5

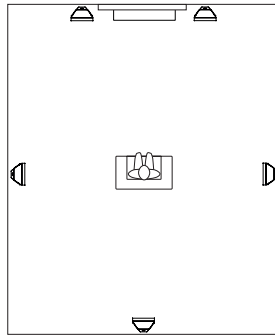

Figure 6

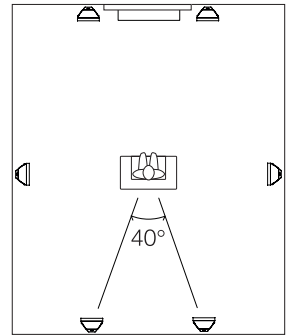

Figure 7a

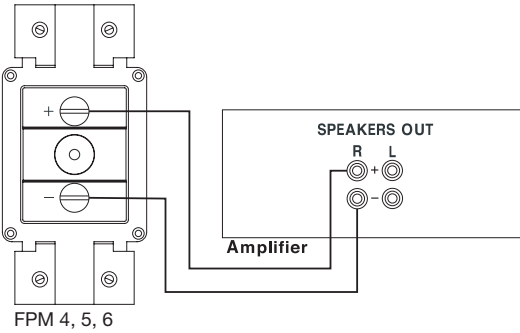

Figure 7b

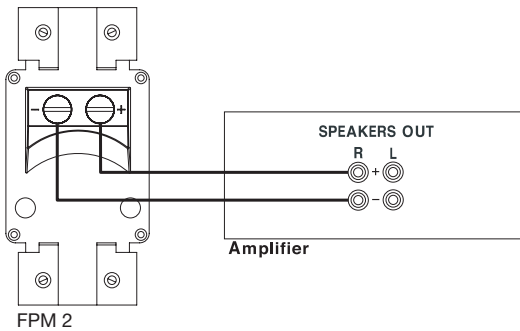

Figure 8

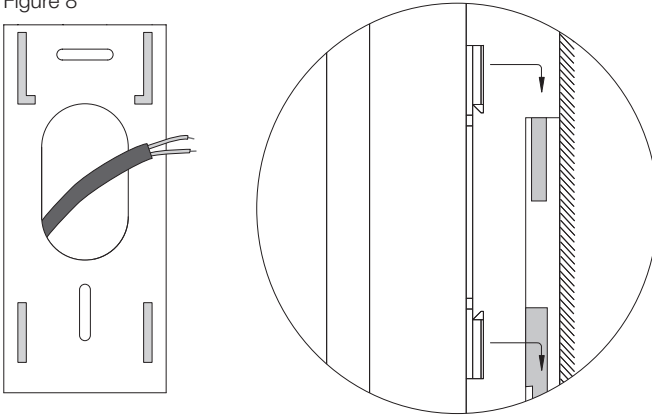

Figure 9

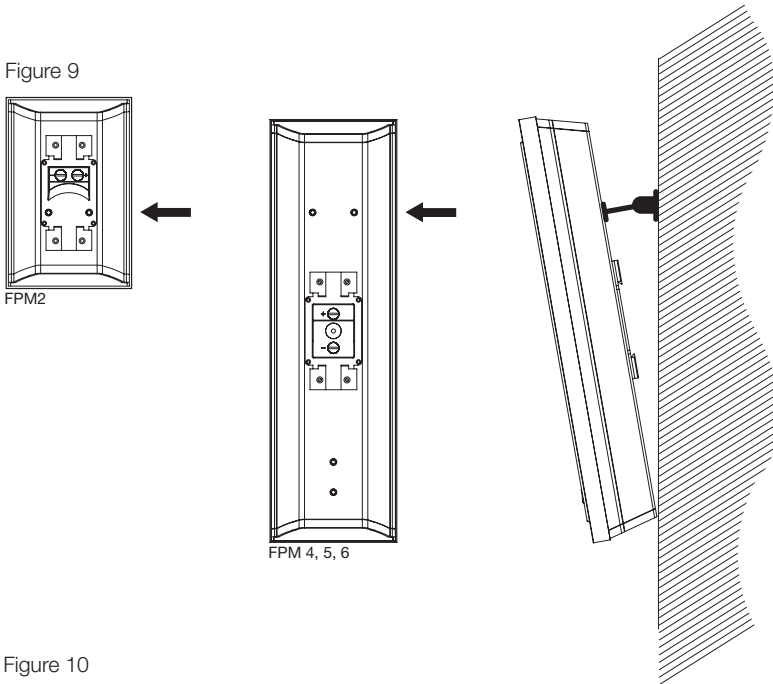
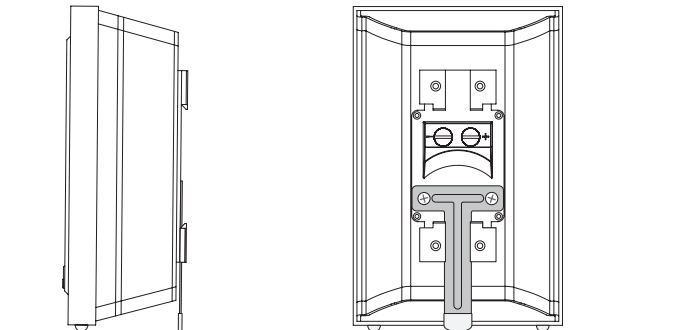

Figure 10



Contents

English

Limited Warranty.....2

Owner's Manual.....2

English

Limited Warranty

Dear customer,

Welcome to Bowers & Wilkins.

This product has been designed and manufactured to the highest quality standards. However, if something does go wrong with this product, B&W Group Ltd and its national distributors warrant free of charge labour (exclusion may apply) and replacement parts in any country served by an official Bowers & Wilkins distributor.

This limited warranty is valid for a period of five years from the date of purchase or two years for electronics including amplified loudspeakers.

Terms and Conditions

- 1 The warranty is limited to the repair of the equipment. Neither transportation, nor any other costs, nor any risk for removal, transportation and installation of products is covered by this warranty.
- 2 This warranty is only valid for the original owner. It is not transferable.
- 3 This warranty will not be applicable in cases other than defects in materials and/or workmanship at the time of purchase and will not be applicable:
 - a. for damages caused by incorrect installation, connection or packing,
 - b. for damages caused by any use other than correct use described in the user manual, negligence, modifications, or use of parts that are not made or authorised by B&W,
 - c. for damages caused by faulty or unsuitable ancillary equipment,
 - d. for damages caused by accidents, lightning, water, fire heat, war, public disturbances or any other cause beyond the reasonable control of B&W and its appointed distributors,
 - e. for products whose serial number has been altered, deleted, removed or made illegible,
 - f. if repairs or modifications have been executed by an unauthorised person.
- 4 This guarantee complements any national/regional law obligations of dealers or national distributors and does not affect your statutory rights as a customer.

How to claim repairs under warranty

Should service be required, please follow the following procedure:

- 1 If the equipment is being used in the country of purchase, you should contact the B&W authorised dealer from whom the equipment was purchased.
- 2 If the equipment is being used outside the country of purchase, you should contact the B&W national distributor in the country of residence who will advise where the equipment can be

serviced. You can call B&W in the UK or visit our web site to get the contact details of your local distributor.

To validate your warranty, you will need to produce this warranty booklet completed and stamped by your dealer on the date of purchase. Alternatively, you will need the original sales invoice or other proof of ownership and date of purchase.

Owner's manual

Introduction

Thank you for choosing Bowers & Wilkins.

We are confident that you will enjoy many years of listening pleasure from your speakers, but please read this manual fully before installing them. It will help you optimise their performance.

B&W maintains a network of dedicated distributors in over 60 countries who will be able to help you should you have any problems your dealer cannot resolve.

Unpacking

We suggest you retain the packing for future use.

Check in the carton for:

- wall plate
- 2x M6 screws
- mounting template
- rear support leg (FPM2 only)
- 2x clear self-adhesive rubber pads (FPM2 only)

Positioning

FPM speakers are balanced for their backs being placed against a wall. However, we recommend you keep them at least 0.5m (20 in) from a side wall, otherwise the bass may be too heavy.

If you intend to attach the speakers to a wall, first ascertain the optimum position before permanently fixing them in place.

Unless using the speakers for home theatre centre channel, we recommend you mount them in vertical orientation. The spring-loaded logo badge on the grille may be rotated after pulling it slightly away from the cloth.

2-channel audio

As an initial guide (figure 1):

- Position the speakers and the centre of the listening area approximately at the corners of an equilateral triangle.
- Keep the speakers at least 1.5m apart to maintain left-right separation.

If the central image is poor, try moving the speakers closer together or, if they are not fixed to the wall using the supplied wall plate, toeing them in so they point at or just in front of the listeners (figure 2).

Multi-channel audio/video

Stray magnetic fields

The speaker drive units create stray magnetic fields that extend beyond the boundaries of the cabinet. We recommend you keep magnetically sensitive articles (CRT television and computer screens, computer discs, audio and video tapes, swipe cards and the like) at least 0.5m (20 in) from the speaker.

Plasma and LCD screens are not affected by these stray magnetic fields.

Front (figure 3)
left and right

The angle between the speakers should normally be less than for 2-channel audio – nearer 40° than 60°. If using a screen, it may be desirable to place the speakers closer to the screen for aesthetic reasons, but be aware that the apparent size of the acoustic image is related to the left and right speaker spacing and ideally you should try to balance this with the picture.

When used with a screen, the mounting height of the speakers should be matched to the screen. In an audio-only installation, set the height so the tweeters at the centre of the speaker are approximately at ear level.

Centre channel

When used with a screen, orient the speaker horizontally and place it close to the top or bottom of the screen, whichever is nearest ear level. In an audio-only installation, orient the speaker vertically and in line with the left and right front speakers.

Surround

Surround speakers are normally placed around 60cm (2 ft) above ear level. It is not always necessary or desirable to point surround speakers directly at the listening area. Doing so can often attract undue attention to them, especially when your head is turned from looking directly to the front, so experiment before investing in special brackets.

5.1 systems (figure 4)

Place the speakers approximately 120° round from front centre. This will determine whether they are placed on the side or rear wall.

6.1 systems with one rear speaker (figure 5)

Place the side speakers in line with the centre of the listening area and one speaker centrally on the rear wall.

7.1 systems and 6.1 systems with two rear speakers (figure 6)

Place the side speakers in line with the centre of the listening area. Place two speakers along the rear wall to make an angle of approximately 40° to the centre of the listening area.

Connections (figure 7)

All connections should be made with the equipment switched off.

Ensure the positive terminal on the speaker (marked +) is connected to the positive output terminal of the amplifier and negative (marked –) to negative.

Always screw the terminal caps down tightly to optimise the connection and prevent rattles.

Ask your dealer for advice when choosing cable. Keep the total impedance below the maximum recommended in the specification and use a low inductance cable to avoid attenuation of the highest frequencies.

Fine tuning

If the sound is too harsh, increase the amount of soft furnishing in the room (for example use heavier curtains), or reduce it if the sound is dull and lifeless.

Test for flutter echoes by clapping your hands and listening for rapid repetitions. Reduce them by the use of irregular shaped surfaces such as bookshelves and large pieces of furniture.

Mounting the speaker

To the wall

Use the wall plate supplied if you do not need to angle the speaker. (figure 8)

At each end of the terminal tray at the back of the speaker is a dovetail feature that slides into the wall plate.

Use the template provided to mark the position of the fixing screws for the wall plate. The overall height and width of the template correspond to the size of the speaker and both the vertical and horizontal centre lines are marked. This allows you to align the speakers with the television screen and any other objects.

Pierce through the screw position marks in the template to leave an indent in the wall. Hold the wall plate against the wall, aligned with the screw marks and trace round the inside of the oval hole, which is used for cable entry.

With solid walls, chase out a channel for the speaker cable, ending where you have marked the oval hole. In cavity walls, simply drill through the plasterboard and feed the cable through into the cavity.

Screw the wall plate to the wall using a spirit level to accurately set it square. Small angular deviations may not be noticeable to the eye when looking at the small plate, but become more obvious with the speaker itself.

Connect the cable before sliding the speaker onto the wall plate.

If you need to angle the speakers, two threaded inserts are provided to allow the use of an auxiliary mounting bracket. We recommend the OmniMount[®] type 10.0 wall or ceiling for the FPM4 and FPM5 and type 20.0 wall or ceiling for the FPM6.

These allow sideways angling and a downward tilt of up to 10° when the bracket is mounted above the terminals and the bottom of the speaker touches the wall. For the FPM2, the Omnimount[®] type 10.0 wall or ceiling allows extensive adjustment of angle. Follow the instructions provided with the bracket and fix the mounting plate to the back of the speaker using the two M6 screws provided with the speaker. (figure 9)

Ensure, especially when fixing to drywall panels, that the screw length and wall plug security are sufficient to hold the weight of the speaker. B&W can accept no liability for any failure of wall or ceiling fixings.

On a shelf or table

(FPM2 only)

A rear support leg is provided to enable the speaker to stand upright on a flat surface.

With the strengthening rib pointing away from the enclosure, attach the leg to the two threaded inserts in the back of the speaker, using the screws provided.

Stick the two clear rubber pads to the underside of the grille frame. (figure 10)

To the optional table stand or floor stand

Mounting instructions are provided with the stands. The table stand allows the speaker to be mounted in either vertical or horizontal orientation. The floor stand allows only vertical orientation.

The FPM2 is not suitable for fixing to either the table stand or the floor stand.

Running-in period

The performance of the speaker will change subtly during the initial listening period. If the speaker has been stored in a cold environment, the damping compounds and suspension materials of the drive units will take some time to recover their correct mechanical properties. The drive unit suspensions will also loosen up during the first hours of use. The time taken for the speaker to achieve its intended performance will vary depending on previous storage conditions and how it is used. As a guide, allow up to a week for the temperature effects to stabilise and 15 hours of average use for the mechanical parts to attain their intended design characteristics.

Aftercare

The cabinets normally only require dusting. If you wish to use an aerosol cleaner, remove the grille first by gently pulling it away from the cabinet. Spray onto the cleaning cloth, not directly the cabinet. With the grille detached from the cabinet, clean the fabric with a normal clothes brush or vacuum cleaner with appropriate accessory.

Avoid touching the drive units, especially the tweeter, as damage may result.

EU DECLARATION OF CONFORMITY

We,

B&W Group Ltd.

whose registered office is situated at

Dale Road, Worthing, West Sussex, BN11 2BH, United Kingdom

declare under our sole responsibility that the products:

FPM2, FPM4, FPM5 and FPM6

comply with the EU Electro-Magnetic Compatibility (EMC) Directive 89/336/EEC, in pursuance of which the following standards have been applied:

EN 61000-6-1 : 2001
EN 61000-6-3 : 2001
EN 55020 : 2002
EN 55013 : 2001

and comply with the EU General Product Safety 2001/95/EC, in pursuance of which the following standard has been applied:

EN 60065 : 2002

This declaration attests that the manufacturing process quality control and product documentation accord with the need to assure continued compliance.

The attention of the user is drawn to any special measures regarding the use of this equipment that may be detailed in the owner's manual.

Signed:



G Edwards
Executive Vice President, Operations
B&W Group Ltd.

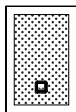

FPM2

Technical features	Nautilus™ tweeter Kevlar® cone bass/midrange
Description	2-way vented-box system
Drive units	1x 25mm (1in) alloy dome high-frequency 1x 110mm (4in) Kevlar® cone bass/midrange
Frequency range	-6dB at 65Hz and 40kHz
Frequency response	80Hz - 20kHz ±3dB on reference axis
Dispersion	Within 2dB of response on reference axis Horizontal: over 40° arc Vertical: over 10° arc
Sensitivity	86dB spl (2.83V, 1m)
Harmonic distortion	2nd & 3rd harmonics (88dB, 1m) <1% 160Hz - 20kHz <0.5% 200Hz - 10kHz
Nominal impedance	8Ω (minimum 4Ω)
Crossover frequencies	2.7kHz
Power handling	25W - 100W into 8Ω on unclipped programme
Max. recommended cable impedance	0.1Ω
Dimensions	Height: 259mm (10.2 in) Width: 170mm (6.7 in) Depth: 102mm (4 in) including wall plate
Net Weight	2.7kg (6 lb)

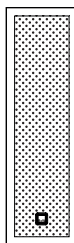

FPM4

Technical features	Nautilus™ tweeter Kevlar® cone bass/midrange Flowport
Description	2½-way vented-box system
Drive units	1x 25mm (1in) alloy dome high-frequency 2x 110mm (4in) Kevlar® cone bass/midrange
Frequency range	-6dB at 65Hz and 42kHz
Frequency response	72Hz - 22kHz ±3dB on reference axis
Dispersion	Within 2dB of response on reference axis Horizontal: over 40° arc Vertical: over 10° arc
Sensitivity	88dB spl (2.83V, 1m)
Harmonic distortion	2nd & 3rd harmonics (88dB, 1m) <1% 100Hz - 20kHz <0.5% 200Hz - 10kHz
Nominal impedance	8Ω (minimum 4Ω)
Crossover frequencies	180Hz, 3.7kHz
Power handling	25W-120W into 8Ω on unclipped programme
Max. recommended cable impedance	0.1Ω
Dimensions	Height: 563mm (22.2 in) Width: 170mm (6.7 in) Depth: 102mm (4 in) including wall plate
Net Weight	4.8kg (10.5 lb)

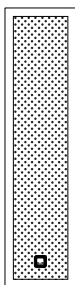

FPM5

Technical features	Nautilus™ tweeter Kevlar® cone bass/midrange Flowport
Description	2 $\frac{1}{2}$ -way vented-box system
Drive unit	1x 25mm (1in) alloy dome high-frequency 2x 110mm (4in) Kevlar® cone bass/midrange
Frequency range	-6dB at 62Hz and 42kHz
Frequency response	69Hz - 22kHz \pm 3dB on reference axis
Dispersion	Within 2dB of response on reference axis Horizontal: over 40° arc Vertical: over 10° arc
Sensitivity	88dB spl (2.83V, 1m)
Harmonic distortion	2nd & 3rd harmonics (88dB, 1m) <1% 100Hz - 20kHz <0.5% 200Hz - 10kHz
Nominal impedance	8 Ω (minimum 4 Ω)
Crossover frequencies	180Hz, 3.7kHz
Power handling	25W-120W into 8 Ω on unclipped programme
Max. recommended cable impedance	0.1 Ω
Dimensions	Height: 665mm (26.2 in) Width: 170mm (6.7 in) Depth: 102mm (4 in) including wall plate
Net Weight	5.5kg (12 lb)

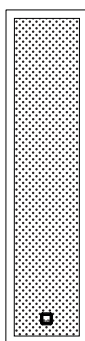

FPM6

Technical features	Nautilus™ tweeter Kevlar® cone bass/midrange Flowport
Description	2 $\frac{1}{2}$ -way vented-box system
Drive unit	1x 25mm (1in) alloy dome high-frequency 2x 130mm (5in) Kevlar® cone bass/midrange
Frequency range	-6dB at 55Hz and 42kHz
Frequency response	65Hz - 22kHz \pm 3dB on reference axis
Dispersion	Within 2dB of response on reference axis Horizontal: over 40° arc Vertical: over 10° arc
Sensitivity	88dB spl (2.83V, 1m)
Harmonic distortion	2nd & 3rd harmonics (88dB, 1m) <1% 100Hz - 20kHz <0.5% 200Hz - 10kHz
Nominal impedance	8 Ω (minimum 3.5 Ω)
Crossover frequencies	180Hz, 4.8kHz
Power handling	25W-150W into 8 Ω on unclipped programme
Max. recommended cable impedance	0.1 Ω
Dimensions	Height: 794mm (31.3 in) Width: 195mm (7.7 in) Depth: 111mm (4.4 in) including wall plate
Net Weight	6.8kg (15 lb)

Owner details

Title, first name, surname _____

Address _____

Town, postcode, country _____

e-mail address _____

Product details

Model _____

Serial number _____

Date of purchase _____

Dealer details

Dealer name _____

Address _____

Town, postcode, country _____

e-mail address _____

Dealer stamp

Bowers & Wilkins

B&W Group Ltd
Dale Road
Worthing West Sussex
BN11 2BH England

T +44 (0) 1903 221 800
F +44 (0) 1903 221 801
info@bwgroup.com
www.bowers-wilkins.com

B&W Group (UK Sales)
T +44 1903 221 500
E uksales@bwgroup.com

B&W Group North America
T +1 978 664 2870
E marketing@bwgroupusa.com

B&W Group Asia Ltd
T +852 3 472 9300
E info@bwgroup.hk

Kevlar is a registered trademark of DuPont.
Nautilus is a trademark of B&W Group Ltd.
Copyright © B&W Group Ltd. E&OE
Printed in China.