

**SB 10/230**

**Passive Soundbar with active subwoofer**



**AVAILABLE AT  
DIGITAL CINEMA**



**CONTENTS**

|                      |   |                                  |    |
|----------------------|---|----------------------------------|----|
| INCLUDED ITEMS       | 2 | SOUNDBAR PACKAGE LIST AND PARTS  | 10 |
| SUBWOOFER REAR PANEL | 3 | SOUNDBAR EXPLODED VIEW / PARTS   | 11 |
| CONNECTIONS          | 5 | SUBWOOFER PACKAGE LIST AND PARTS | 12 |
| OPERATION            | 7 | SUBWOOFER EXPLODED VIEW / PARTS  | 13 |
| TROUBLESHOOTING      | 8 | SUBWOOFER SCHEMATIC DIAGRAMS     | 14 |
| SPECIFICATIONS       | 9 |                                  |    |

### Included Items

One SB 10 three-channel soundbar speaker

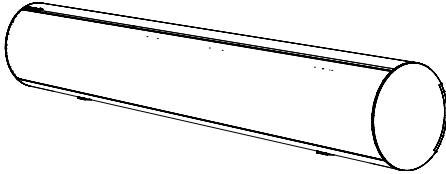

One combination LFE/trigger cable

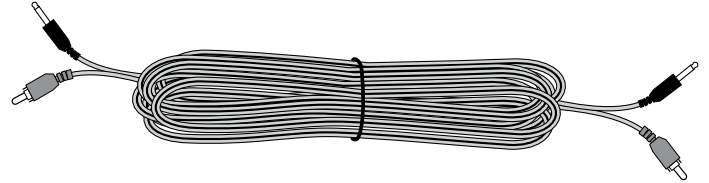

One 8" (203mm) 200-watt subwoofer

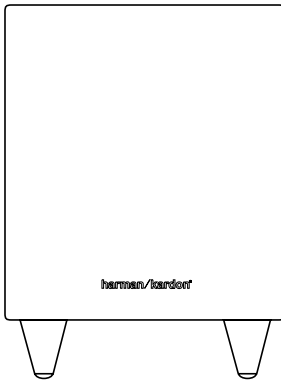

**Important:** If anything is missing, or if any part of your SB 10 system fails to operate properly, contact your dealer immediately.

Two wall-mount brackets for the SB 10 soundbar

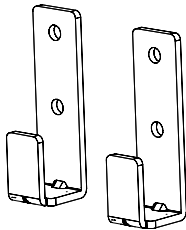

Three speaker cables

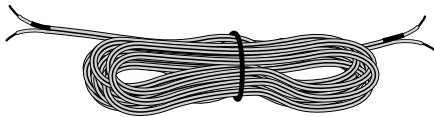

## Subwoofer Rear-Panel Connections

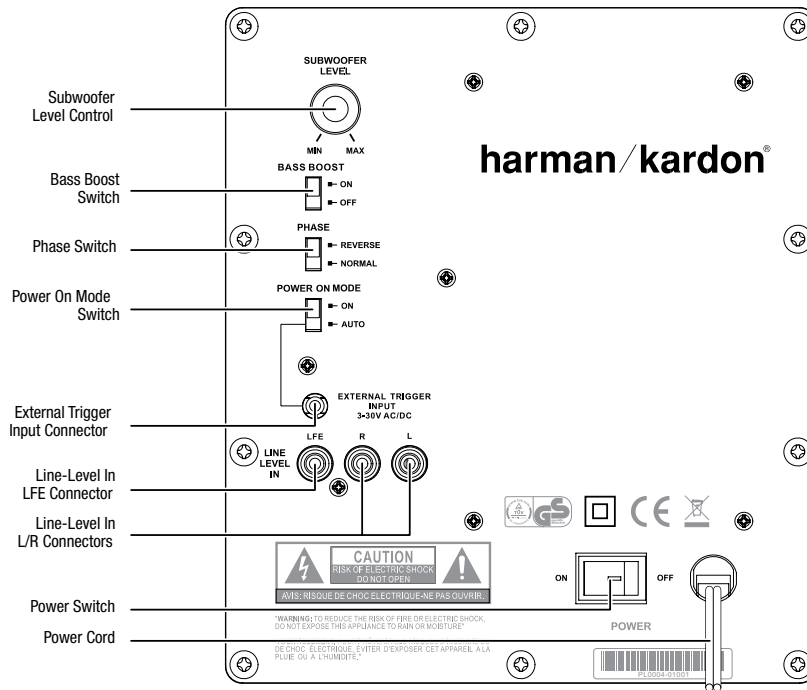

**Phase Switch:** This switch determines whether the subwoofer driver's piston-like action moves in and out in phase with the satellite speakers. If the subwoofer were to play out of phase with the satellite speakers, the sound waves from the satellites could cancel out some of the sound waves from the subwoofers, reducing bass performance and sonic impact. This phenomenon depends in part on the placement of all the speakers relative to each other in the room.

**Bass Boost Switch:** Set this switch to "On" to enhance the subwoofer's low-frequency performance. Set this switch to "Off" for normal low-frequency performance.

**Power-On Mode Switch:** When this switch is set in the "Auto" position and when the Power Switch is set to "On," the subwoofer will automatically turn itself on when it receives an audio signal and will enter the Standby mode when it has gone without receiving an audio signal for 20 minutes. When this switch is set in the "On" position, the subwoofer will remain on whether or not it is receiving an audio signal.

When the Power-On Mode Switch is in the "Auto" position, the LED light next to the switch indicates whether the subwoofer is in the On or Standby mode:

- When the LED glows blue, the subwoofer is in the On mode.
- When the LED is off, the subwoofer is in Standby mode.

When the Power Switch is set to "Off," the LED will not light up, no matter what setting the Power-On Mode Switch is in.

**Subwoofer Level Control:** Use this control to adjust the subwoofer's volume. Turn the knob clockwise to increase the volume; turn the knob counterclockwise to decrease the volume.

**External Trigger Input Connector:** Use the mini-plug of the supplied combination LFE and trigger cable to connect the External Trigger Input Connector to the trigger output of another compatible component. Whenever the subwoofer amplifier detects a trigger signal between 3V and 30V (AC or DC) the amplifier will turn on. The subwoofer amplifier will turn off after the trigger signal ceases, even when the Power-On Mode Switch is in the "Auto" position.

**Line-Level In LFE Connector:** This input bypasses the subwoofer's internal crossover circuitry, so use it only with a receiver or processor subwoofer output that has been low-pass filtered. If your receiver or processor does not have a dedicated subwoofer output that is low-pass filtered, you should use the subwoofer's Line-Level In L/R Connectors instead (see below).

Use the supplied LFE cable (the one with purple connectors) to connect the Line-Level In LFE Connector to the dedicated subwoofer output of a receiver or preamp/processor.

**Line-Level In L/R Connectors:** These inputs pass through the subwoofer's built-in crossover. Use them if your receiver or preamp/processor does not have a dedicated subwoofer output that is low-pass filtered.

- If your receiver or preamp/processor has a subwoofer output, use the supplied LFE/trigger cable to connect it to either one of the subwoofer's Line-Level L/R In Connectors.
- If your receiver or preamp/processor does not have a separate subwoofer output, use two Y-adapters (not supplied). Connect an adapter's single end to the unit's preamp output for that channel. Connect one of the adapter's dual ends to the main amp input for that channel, and connect the adapter's other dual end to one of the subwoofer's Line-Level L/R In Connectors. Repeat the process with the other Y-adapter, preamp channel, main amp input and subwoofer Line-Level L/R In Connector.

**Power Switch:** Set this switch in the "On" position to turn the subwoofer on. The subwoofer will then be in either On or Standby mode, depending on the setting of the Power-On Mode Switch.

**Power Cord:** After you have made and verified all subwoofer and speaker connections described in this manual, plug this cord into an active, *unswitched* electrical outlet for proper operation of the subwoofer. DO NOT plug this cord into the accessory outlets found in some audio components.

## Speaker Placement

### Placing the Soundbar on a Table

If your TV is placed on a table, you can place the soundbar on the table directly in front of the TV stand, centered with the TV screen. As long as the surface of the table is flat, the soundbar will rest on its rubber bumpers.

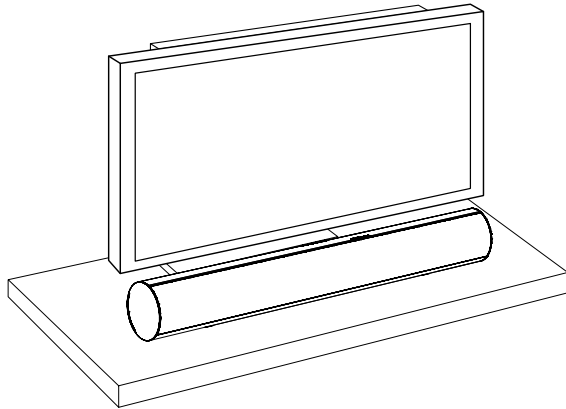

If your TV is located in an entertainment or media center, you can mount the soundbar in a space directly above or below the TV.

**Warning:** Do NOT place the soundbar directly on top of a TV or at the front of a table or cabinet. It could roll forward and injure someone.

### Wall-Mounting the Soundbar

If your TV is attached to a wall, you can use the included wall-mount brackets to mount the soundbar on the wall directly below the TV screen.

1. Determine the location for the soundbar on the wall. Make sure that the top of the soundbar will not block your view of the TV screen when it is mounted on the wall.
2. Mark the locations of the soundbar wall-mount bracket holes on the wall. The holes for the left and right brackets are spaced 600mm (23-5/8") apart. The top and bottom holes for each bracket are spaced 25mm (1") apart. See the illustration below.

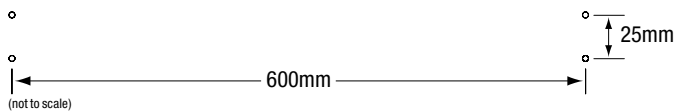

**NOTE:** To ensure that the soundbar will be level, use a carpenter's level, laser sight or other device to help you determine that the two sets of holes are at exactly the same height.

Attach the two wall-mount brackets to the wall at the locations you marked, using hardware that is appropriate for the wall's construction and materials. Note that the soundbar weighs 3.67kg (8.1 lb). Be sure to use hardware that can support this weight.

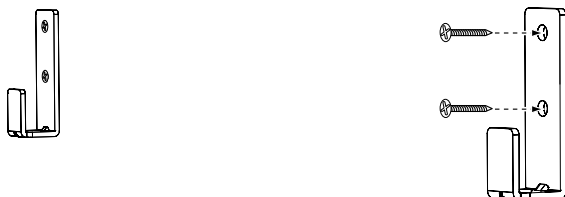

After making all of the connections described in the *Connections* section, on page 8, attach the soundbar to the brackets by sliding the slots in its rubber bumpers onto the brackets' vertical tabs.

### Placing the Subwoofer

Since our ears cannot locate the source of sounds at the low frequencies that the subwoofer produces, it will perform well from just about any location in your room. However, you are likely to hear the strongest bass reproduction when you place the subwoofer in a corner along the same wall as the soundbar.

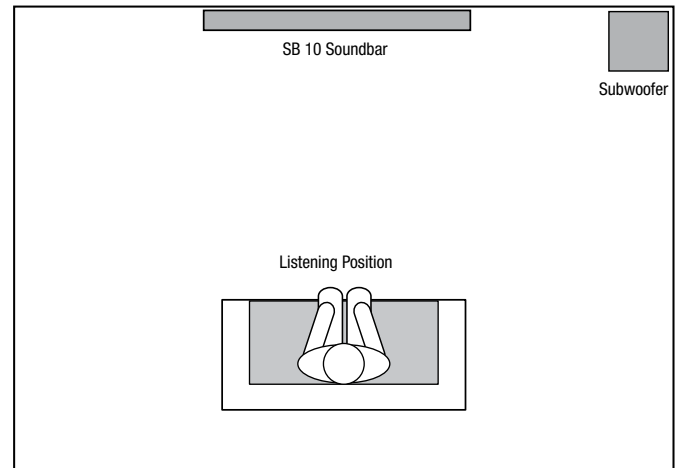

You can determine the best location for the subwoofer by temporarily placing it in the listening position and playing music with strong bass content. Move around to various locations in the room while the system is playing, and listen until you find the location where the bass performance is best. Place the subwoofer in that location.

## Connections

**CAUTION:** Before making speaker connections, be sure that your receiver or amplifier is turned off. If possible, make sure that its AC cord is unplugged from the AC power outlet.

### Soundbar Connections

The SB 10 soundbar contains left-, center- and right-channel speakers that connect to your audio/video receiver or amplifier's front left, center and front right speaker outputs.

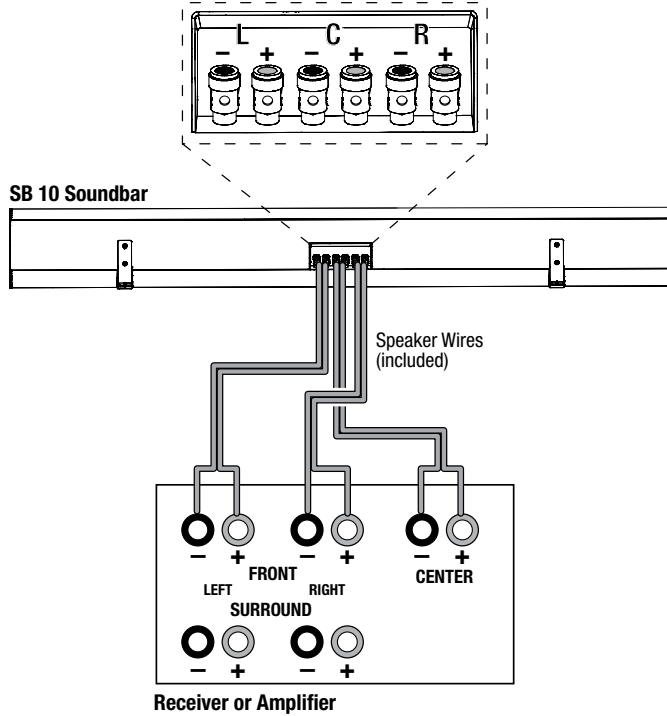

To connect each wire to the soundbar:

1. Press down on the terminal cap to open the connection hole on the soundbar's speaker terminal.
2. Insert the wire's bare end all the way into the hole. Insert the colored band into the speaker's red (+) terminal, and insert the colored conductor into the speaker's black (-) terminal, as shown in the illustration.
3. Release the cap to secure the wire.

1. Push Down on Cap to Open Hole

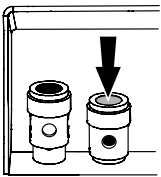

2. Insert Wire Into Open Hole

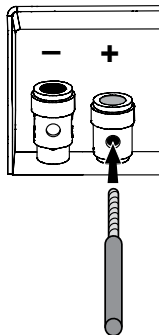

3. Release Cap to Secure Wire

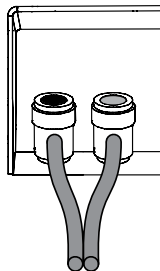

**IMPORTANT:** Make sure the (+) and (-) bare wires do not touch each other or the other terminal. Touching wires can cause a short circuit that can damage your receiver or amplifier.

### Subwoofer Connections

- 1a. If your receiver/processor has a dedicated subwoofer output with low-pass filtering (also called bass management), use the included LFE cable to connect the subwoofer's Line-Level LFE In jack to the dedicated subwoofer output (or LFE output) of your receiver or preamp/processor.

Configure your receiver or preamp/processor's setup menu for Subwoofer ON, and set the front left, front right, center and surround speakers to Small.

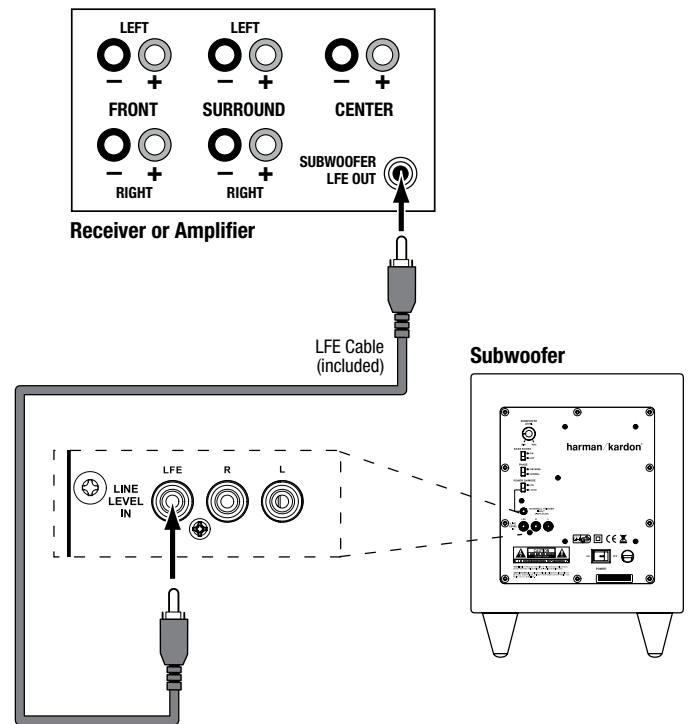

1b. If your receiver/processor does not have a dedicated subwoofer output but does have preamp-level (volume-controlled) line outputs, use the included LFE cable to connect one of those outputs to either of the subwoofer's Line-Level L/R In Connectors. Use an RCA cable (not supplied) to connect the other receiver or preamp line output to the other subwoofer Line-Level L/R In Connector.

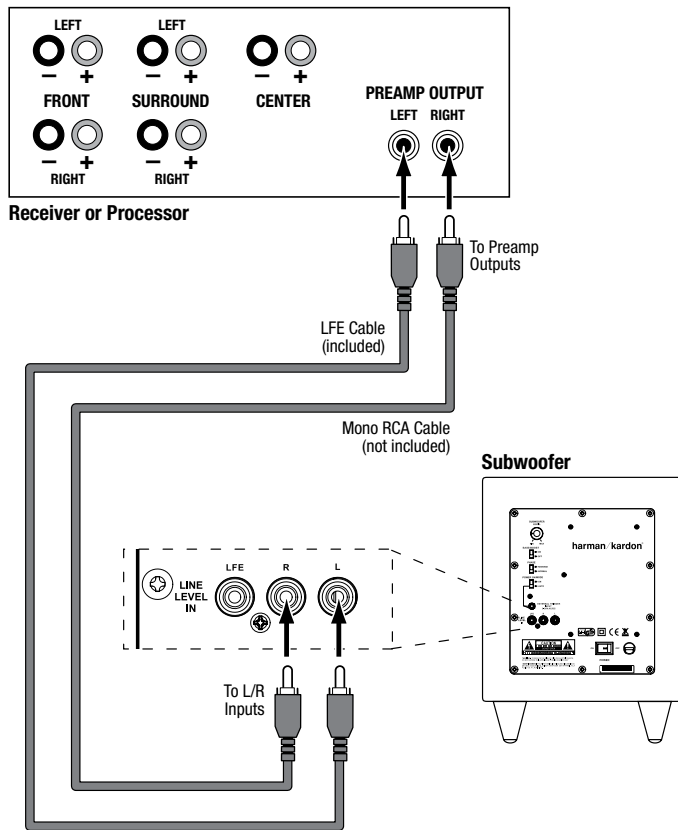

If you're connecting to a receiver or preamp/processor with left and right line outputs that are connected to front left and front right amplifier inputs, connect the single ends of Y-adapters (not supplied) to the receiver or processor's left and right line outputs. Connect one of the Y-adapter's double ends to the subwoofer's Line-Level L/R In Connectors, and connect the other double end to your amplifier's front left and front right inputs.

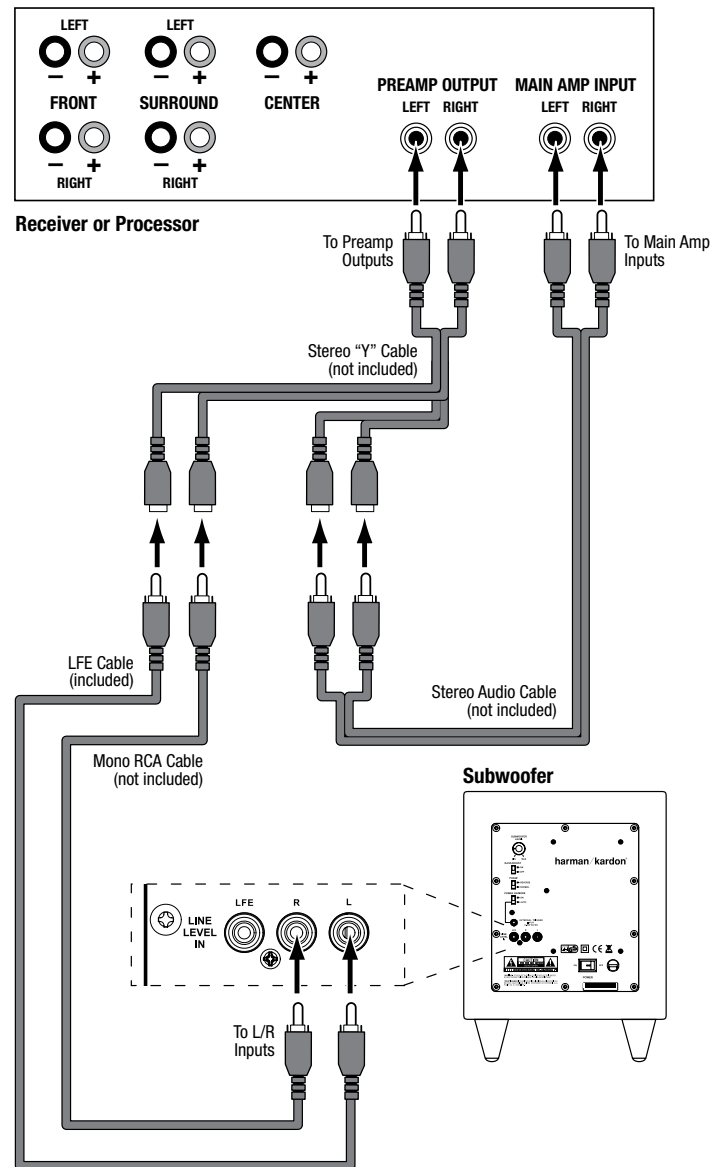

2. After you have made and verified all other connections, plug the subwoofer's Power Cord into an active, unswitched AC outlet. DO NOT plug this cord into the accessory outlets found on some audio components.

## Operation

### Turning the Subwoofer On and Off

Set the subwoofer's Power Switch to the "On" position.

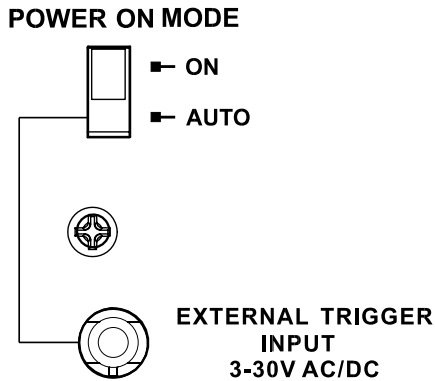

- If you set the Power-On Mode Switch to "Auto," the subwoofer will automatically turn itself on when it receives an audio signal, and it will go into Standby mode once it has received no audio signal for 20 minutes. The subwoofer's LED will glow blue when the subwoofer is on, and will not light up when the subwoofer is in Standby mode.
- If the Power-On Mode Switch is set to "On," the subwoofer will remain on at all times. The subwoofer's LED will glow blue.

If the External Trigger Input Connector is connected to a voltage source, the subwoofer will turn on whenever the source generates a trigger voltage and will go into Standby mode 10 to 15 minutes after the trigger voltage ceases, regardless of the position of the Power-On Mode Switch.

If you will not be using the subwoofer for an extended period, set the Power Switch to the "Off" position.

### Subwoofer Adjustments: Volume

Use the Subwoofer Level Control to set the subwoofer's volume. Turn the knob clockwise to increase the subwoofer's volume; turn the knob counterclockwise to decrease the volume. Once you have balanced the subwoofer's volume with that of the other speakers in your system, you shouldn't have to change it.

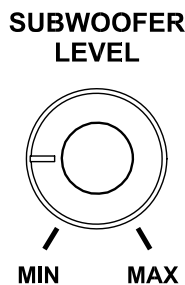

### Subwoofer Adjustments: Phase

This switch determines whether the subwoofer driver's piston-like action moves in and out in phase with the satellite speakers. If the subwoofer were to play out of phase with the satellite speakers, the sound waves from the satellites could cancel out some of the sound waves from the subwoofer, reducing bass performance and sonic impact. This phenomenon depends in part on the placement of all the speakers relative to each other in the room.

Although in most cases you should leave the Phase Switch in the "Normal" position, there is no absolutely correct setting for the Phase Switch. When the subwoofer is properly in phase with the satellite speakers, the sound will be clearer and have maximum impact, and percussive sounds like drums, piano and plucked strings will sound more lifelike. The best way to set the Phase Switch is to listen to music that you know well and set the switch in the position that gives drums and other percussive sounds maximum impact.

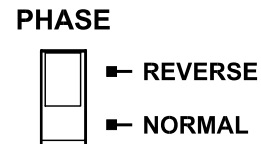

### Subwoofer Adjustments: Bass Boost

When set to the "On" position, the Bass Boost Switch enhances low-frequency performance. The results: bass with more impact, which you may prefer while watching movies or listening to music. There is no harm in experimenting with this control. Setting the switch to the "Off" position will return the subwoofer to its normal low-frequency performance.

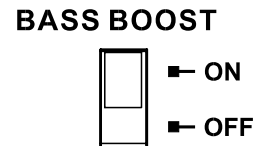

## Troubleshooting

This unit is designed for trouble-free operation. Most problems users encounter are due to operating errors. So if you have a problem, first check this list for a possible solution. If the problem persists, consult your authorized Harman Kardon service center.

| Problem  | Solution   |
|--|--|
| If no sound comes from any of the soundbar speakers:                     | <ul style="list-style-type: none"> <li>• Check that the receiver/amplifier is on and a sound source is playing.</li> <li>• Make sure that all wires between the receiver/amplifier and the soundbar are connected properly.</li> <li>• Make sure that none of the speaker wires is frayed, cut or punctured.</li> <li>• Review the proper operation of your receiver/amplifier.</li> </ul>   |
| If there is no sound coming from the soundbar's left or right speaker:   | <ul style="list-style-type: none"> <li>• Check that the balance control on your receiver/amplifier is not set all the way to one channel.</li> <li>• Check your receiver/amplifier's speaker-setup procedure to make sure that the speaker in question has been enabled and that its volume level has not been turned all the way down.</li> <li>• Make sure that all wires between the receiver/amplifier and the soundbar left or right speaker terminals are connected properly.</li> <li>• Make sure that the speaker wires are not frayed, cut or punctured.</li> </ul>                             |
| If there is no sound coming from the soundbar's center speaker:          | <ul style="list-style-type: none"> <li>• Check your receiver/amplifier's speaker-setup procedure to make sure that the center speaker has been enabled and its volume level has not been turned all the way down.</li> <li>• Make sure that all wires between the receiver/amplifier and the soundbar's center speaker terminals are connected properly.</li> <li>• Make sure that the speaker wires are not frayed, cut or punctured.</li> <li>• If your receiver is operating in Dolby® Pro Logic® mode, make sure that the center speaker is not set to Phantom.</li> </ul>                           |
| If the subwoofer does not turn on:                                       | <ul style="list-style-type: none"> <li>• Check that the subwoofer's Power Cord is plugged into a working AC outlet.</li> <li>• Check that the subwoofer's Power Switch is in the On position.</li> </ul>   |
| If there is no sound coming from the subwoofer:                          | <ul style="list-style-type: none"> <li>• Check that the subwoofer's Power Cord is plugged into a working AC outlet.</li> <li>• Check that the subwoofer's Power Switch is in the "On" position.</li> <li>• Check that the Subwoofer Level Control is not turned all the way down (fully counterclockwise).</li> <li>• Check the audio cable connection between your receiver/processor and the subwoofer.</li> <li>• Check your receiver/amplifier's speaker-setup procedure to make sure that the subwoofer has been enabled and that its volume level has not been turned all the way down.</li> </ul> |
| If the system plays at low volumes but shuts off as volume is increased: | <ul style="list-style-type: none"> <li>• Make sure that all wires between the receiver/amplifier and the soundbar are connected properly.</li> <li>• Make sure that none of the speaker wires is frayed, cut or punctured.</li> <li>• If you have an additional pair of front speakers connected to your receiver/amplifier, make sure that you're not operating the system below the receiver/amplifier's minimum impedance requirements. Check the receiver/amplifier's documentation for more information.</li> </ul>   |

You can find additional troubleshooting information in the FAQs link on the Support page at [www.harmankardon.com](http://www.harmankardon.com).



## Specifications

### SB 10 system

Frequency response: 45Hz – 20kHz (–6dB)

### SB 10 soundbar speaker

#### Low-frequency transducer

Left: 3" (76mm) paper cone, video-shielded

Right: 3" (76mm) paper cone, video-shielded

Center: Two 3" (76mm) paper cones, video-shielded

#### High-frequency transducer

Left: 3/4" (19mm) silk dome, video-shielded

Right: 3/4" (19mm) silk dome, video-shielded

Center: 3/4" (19mm) silk dome, video-shielded

#### Recommended power handling

Left –Right: 60 watts (each)

Center: 100 watts

Nominal impedance: 8 ohms (each channel)

Sensitivity (2.83V/1m): 84dB (each channel)

Crossover frequency: 2.2kHz, 24dB/octave

Connector type: Push-spring terminal

Enclosure type: Sealed

Finish: Gloss black

Dimensions (H x W x D): 4-5/16" x 36-1/4" x 3-1/2"  
(110mm x 920mm x 89mm)

Weight: 8.1 lb (3.67kg)

### Powered Subwoofer

Low-frequency transducer: 8" (203mm) down-firing cone, video-shielded

Amplifier power: 200 watts

Frequency response: 45Hz – 200Hz (–6dB)

Controls: Volume, phase, bass boost

Connections: LFE input, left and right RCA line-level inputs

Enclosure type: Sealed

Finish: Gloss black

Power requirement: AC 100 ~ 120V, 50/60Hz, 200W or

AC 220 ~ 240V, 50/60Hz, 200W

Power consumption: <1W (standby); 200W (maximum)

Dimensions (H x W x D): 13-29/32" x 10-1/2" x 10-1/2"  
(353mm x 267mm x 267mm)

Weight: 19.8 lb (9kg)

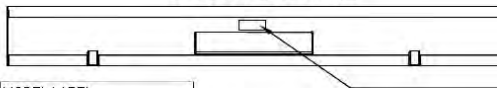

410-000-07039-E (1)  
411-000-08673-E (2)  
貼在機種貼上空格內

|    |                    |                         |
|----|--------------------|-------------------------|
| 1  | 410-000-07039-E    | MODEL LABEL             |
| 2  | 411-000-08673-E    | SERIAL NR. LABEL        |
| 3  | 320-NBR-05244-0BAE | RUBBER FOOT             |
| 4  | 370-000-05105-E    | 1.5 METER SPEAKER CABLE |
| 5  | 370-000-05106-E    | 1.5 METER SPEAKER CABLE |
| 6  | 370-000-05107-E    | 1.5 METER SPEAKER CABLE |
| 7  | 376-000-01249-0BAE | SCREW BAG               |
| 8  | 403-000-05986-E    | ACCESSORY BOX           |
| 9  | 435-000-05196-E    | EPE ( END )             |
| 10 | 431-000-07021-E    | EPE ( MID-TOP )         |
| 11 | 430-002-05391-E    | PEARL BAG               |
| 12 | 431-000-07026-E    | EPE ( MID-BOTTOM )      |
| 13 | 431-000-07225-E    | EPE ( END )             |
| 14 | 398-000-00304-E    | DESSICANT               |
| 15 | 402-000-06410-E    | BEAUTY CARTON           |
| 16 | 413-000-06384-E    | LABEL OF ORIGIN         |
| 17 | 413-000-05591-E    | STATIC FOIL FOR LOGO    |

(3) 320-NBR-05244-0BAE\*2  
(4) 370-000-05105-E\*1  
(5) 370-000-05106-E\*1  
(6) 370-000-05107-E\*1  
(7) 376-000-01249-0BAE\*1

所有附件放入此  
處並用膠帶封口

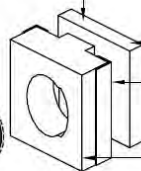
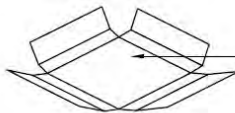

403-000-05986-E (8)  
435-000-05196-E (9)

(17) 413-000-05591-E  
貼在銘板上

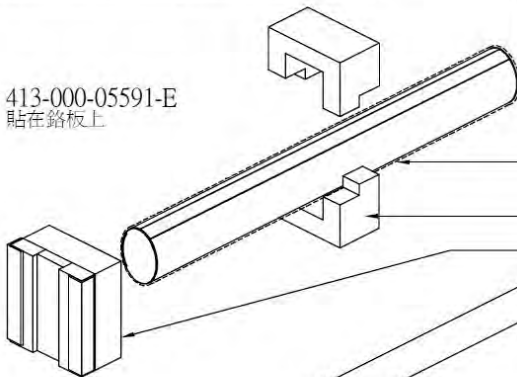

431-000-07021-E (10)  
430-002-05391-E (11)  
431-000-07026-E (12)  
431-000-07225-E (13)

398-000-00304-E (14)  
固定在功放後面膠袋上

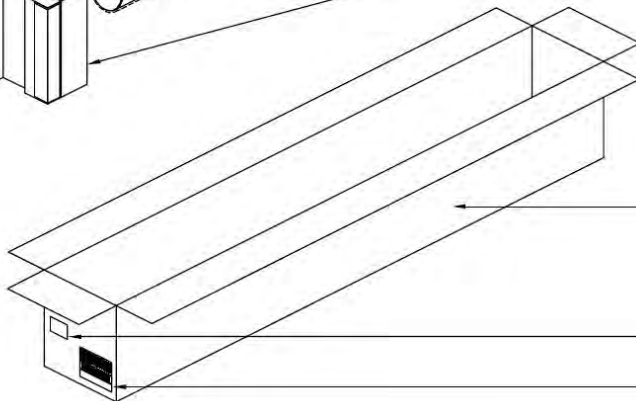

402-000-06410-E (15)  
413-000-06384-E (16)  
411-000-08673-E (2)

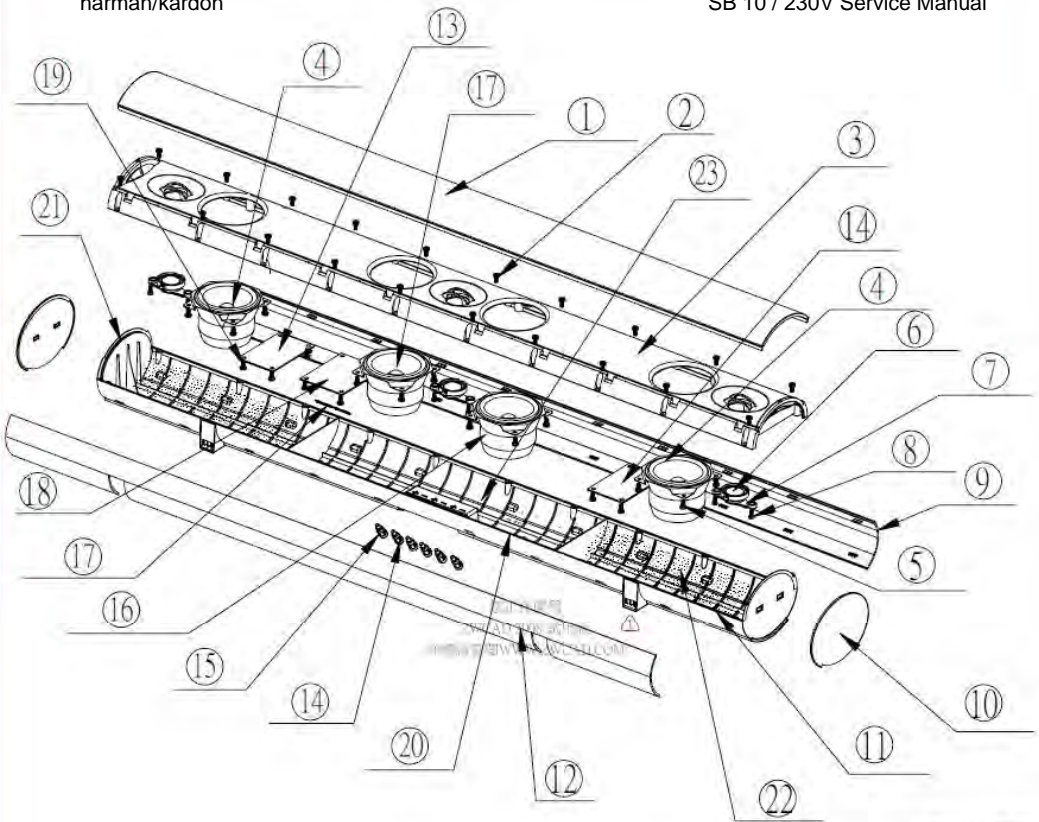

螺絲均要點膠

| ITEM | PART         | PN                 | QTY | ITEM | PART                      | PN                 | QTY |
|------|--------------|--------------------|-----|------|---------------------------|--------------------|-----|
| 1    | GRILLE       | 329-030-05464-0BAE | 1   | 13   | CROSSOVER                 | 013-AA00-05829-E   | 2   |
| 2    | SCREW        | 352-AM03510D112-E  | 20  | 14   | BINDING POST ( NEGATIVE ) | 317-CU-05203-0BAE  | 3   |
| 3    | BAFFLE       | 243-030-05281-0BAE | 1   | 15   | BINDING POST ( PLUS )     | 317-CU-05203-0RAE  | 3   |
| 4    | WOOFER       | 32PF55JZH-HW05-E   | 2   | 16   | WOOFER                    | 32PF55JZP-PW02-E   | 2   |
| 5    | SCREW        | 352-AM04008C1334-E | 16  | 17   | LOGO                      | 316-AG-00556-0VAE  | 1   |
| 6    | TWEETER      | 32DS20AX-HT01-E    | 3   | 18   | CROSSOVER                 | 013-AA00-05830-E   | 1   |
| 7    | TWEETER BAR  | 398-ABS-05062-E    | 3   | 19   | SCREW                     | 352-HM03508C1467-E | 12  |
| 8    | SCREW        | 352-AM03008C1086-E | 6   | 20   | EVA                       | 214-000-05436-0BAE | 2   |
| 9    | BOTTOM PANEL | 315-ABS-05231-0BAE | 1   | 21   | EVA                       | 214-000-05409-0BAE | 4   |
| 10   | SIDE END CAP | 305-ABS-05037-0BAE | 2   | 22   | INSULATION                | 328-000-05931-0WAE | 2   |
| 11   | REAR CLOSURE | 247-030-05103-0AAE | 1   | 23   | INSULATION                | 328-000-05855-0WAE | 1   |
| 12   | TOP PANEL    | 315-ABS-05267-0NAE | 1   |      |                           |                    |     |

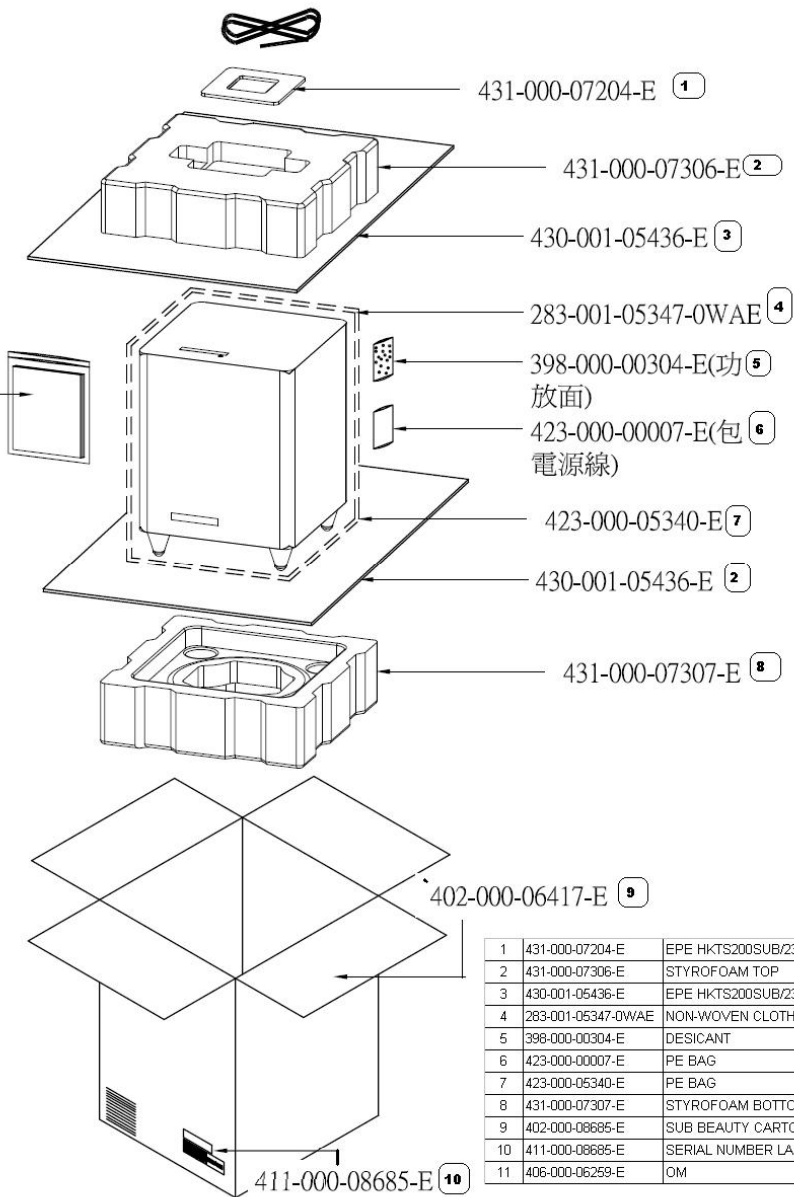
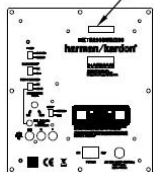

406-000-06259-E  
OM to be placed on the side

(11)

283-001-05347-0WAE (4)

398-000-00304-E (功  
放面)

423-000-00007-E (包  
電源線)

423-000-05340-E (7)

430-001-05436-E (2)

431-000-07307-E (8)

402-000-06417-E (9)

|    |                    |                     |
|----|--------------------|---------------------|
| 1  | 431-000-07204-E    | EPE HKTS200SUB/230  |
| 2  | 431-000-07306-E    | STYROFOAM TOP       |
| 3  | 430-001-05436-E    | EPE HKTS200SUB/230  |
| 4  | 283-001-05347-0WAE | NON-WOVEN CLOTH     |
| 5  | 398-000-00304-E    | DESICCANT           |
| 6  | 423-000-00007-E    | PE BAG              |
| 7  | 423-000-05340-E    | PE BAG              |
| 8  | 431-000-07307-E    | STYROFOAM BOTTOM    |
| 9  | 402-000-06417-E    | SUB BEAUTY CARTON   |
| 10 | 411-000-08685-E    | SERIAL NUMBER LABEL |
| 11 | 406-000-06259-E    | OM                  |

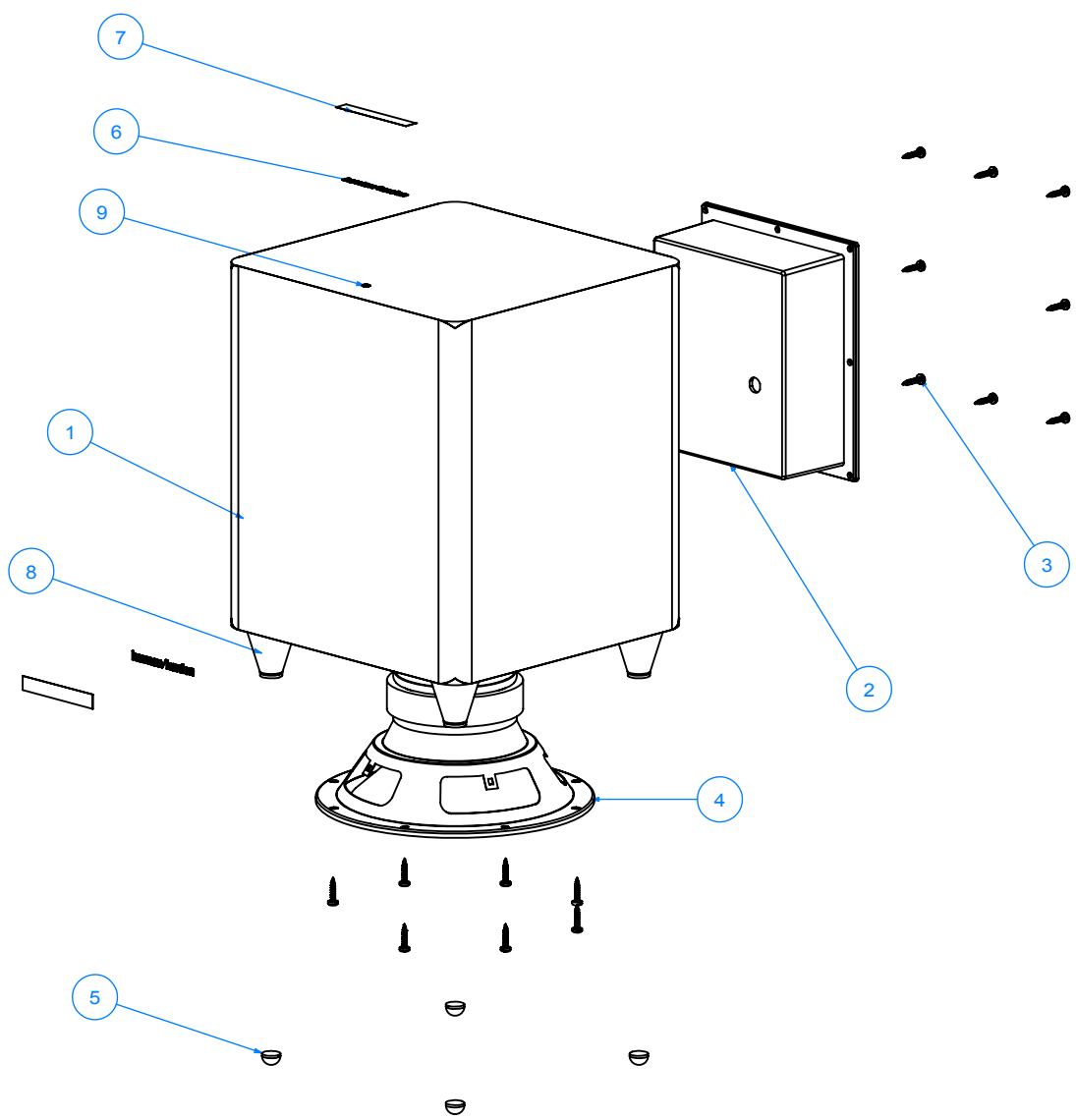

| Item | Part Name          | Description  | Q'ty |
|------|--------------------|--------------|------|
| 1    | 241-080-05531-0BAE | Cabinet      | 1    |
| 2    | 010-0N20-05317-E   | Amplifier    | 1    |
| 3    | 352-FM04020D605-E  | Screw        | 16   |
| 4    | 24MR11DZA-DW01-E   | 8" Subwoofer | 1    |
| 5    | 320-SR-05226-0BAE  | Rubber Feet  | 4    |
| 6    | 316-AG-00557-E     | LogoBadge    | 2    |
| 7    | 413-000-05591-E    | Static Label | 2    |
| 8    | 321-ABS-05141-0BAE | Plastic Feet | 4    |
| 9    | 162-A025D023-E     | LED+Cable    | 1    |

1

2

3

4

A

A

B

B

C

C

D

D

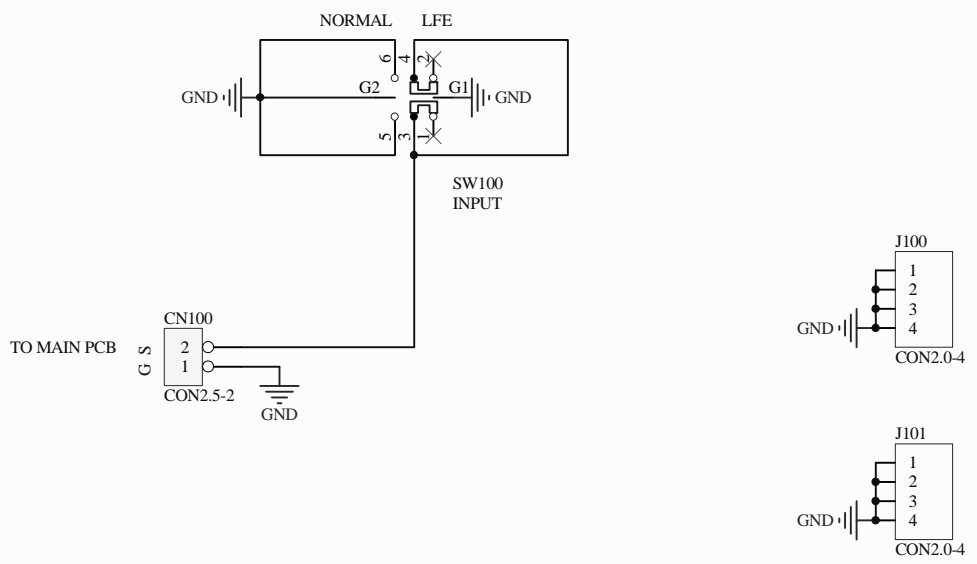

|            |                              |           |
|------------|------------------------------|-----------|
| Title      |                              |           |
| Size<br>A4 | Number                       | Revision  |
| Date:      | 2010/8/3                     | Sheet of  |
| File:      | D:\HKTS200\DV1\LFE_SW.SchDoc | Drawn By: |

1

2

3

4

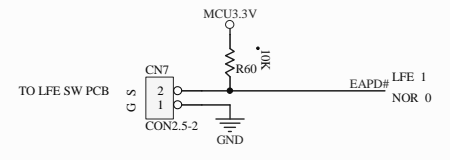
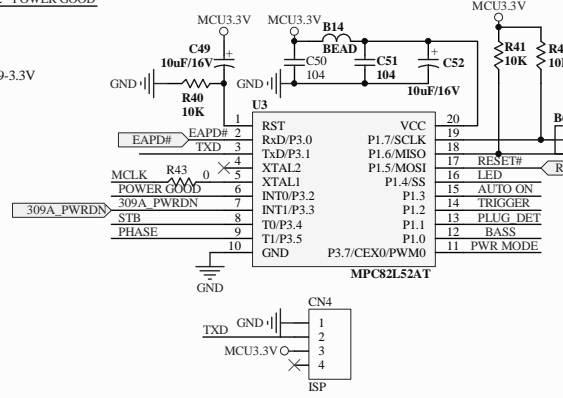
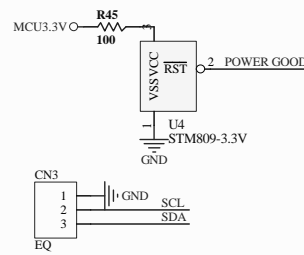
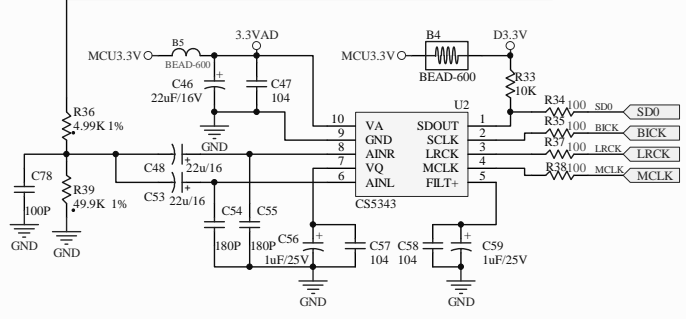
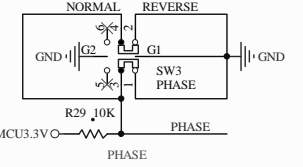
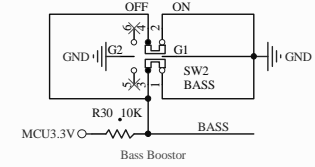
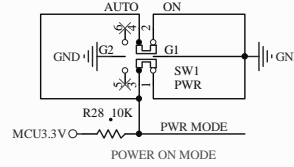
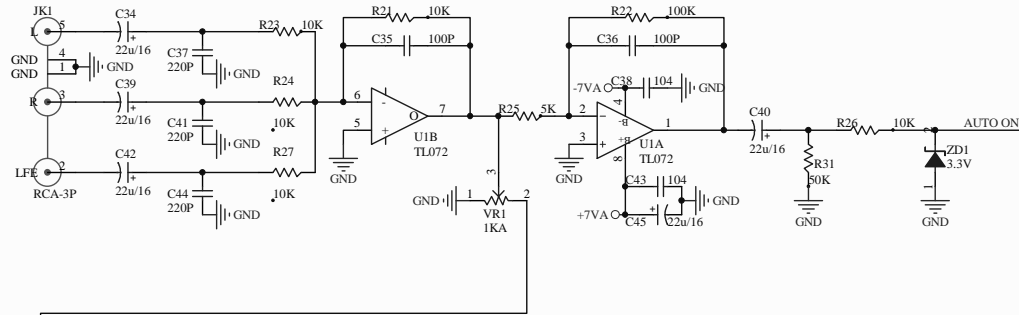

|          |        |        |     |     |     |
|----------|--------|--------|-----|-----|-----|
| PLUG_DET | 0      | 0      | 0   | 1   | 1   |
| TIGGER   | 0      | 0      | 0   | 0   | 1   |
| PWR MODE | (AUTO) | (AUTO) | (0) | (0) | (X) |
| AUTO ON  | 1      | 0      | X   | X   | X   |
| STB      | 1      | 0      | 1   | 0   | 1   |
| LED      | 1      | 0      | 1   | 0   | 1   |

AUTO OFF TIME=15 MIN

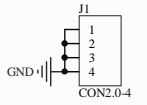
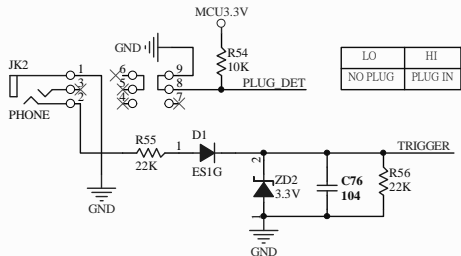
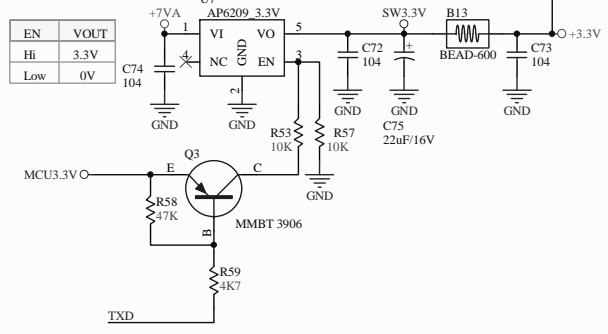
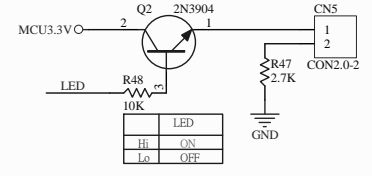
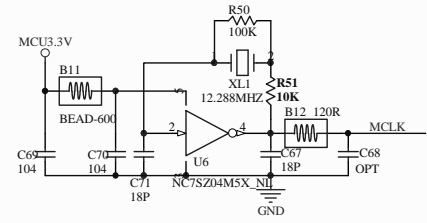
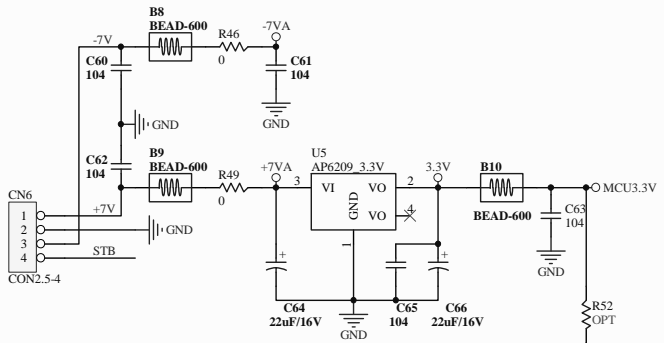

|       |                                 |           |            |  |  |
|-------|---------------------------------|-----------|------------|--|--|
| Title |                                 |           | HKTS200SUB |  |  |
| Size  | Number                          | Revision  |            |  |  |
| A3    |                                 |           |            |  |  |
| Date: | 2010/8/3                        | Sheet of  |            |  |  |
| File: | D:\HKTS200\DV1\INPUT_DV1.SchDoc | Drawn By: |            |  |  |

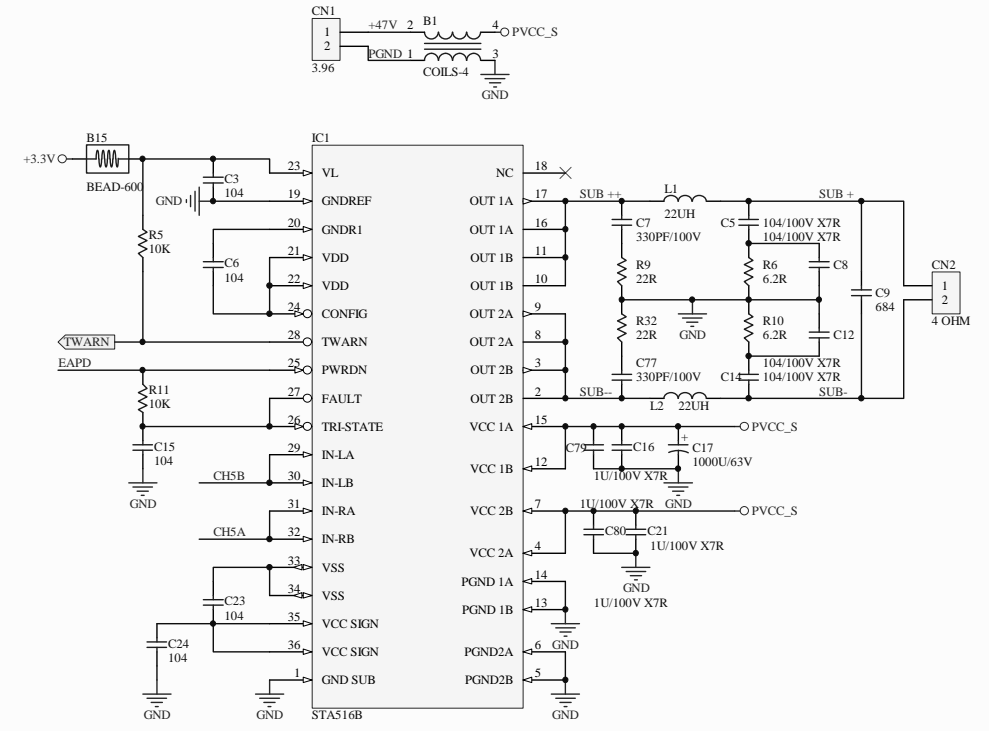
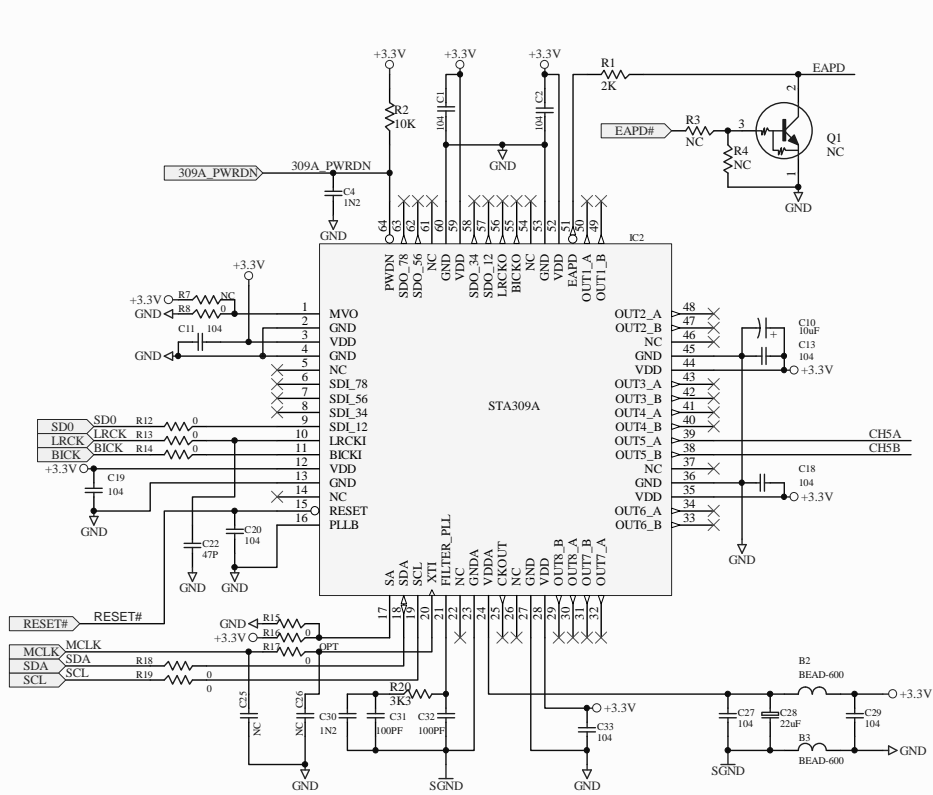

|            |                               |           |
|------------|-------------------------------|-----------|
| Title      |                               |           |
| HKTS200SUB |                               |           |
| Size       | Number                        | Revision  |
| A3         |                               |           |
| Date:      | 2010/8/3                      | Sheet of  |
| File:      | D:\HKTS200\DV1\AMP_DV1.SCHDOC | Drawn By: |