

Klipsch®

DIGITAL
CINEMA

AVAILABLE AT
DIGITAL CINEMA



CP SERIES

OWNER'S MANUAL

RECOMMENDED RECEIVER/AMPLIFIER POWER TO USE WITH KLIPSCH CP SPEAKERS

A speaker can be damaged just as easily with too little power as with too much power. A general rule is when you raise the volume level on a receiver/amplifier past the "one half" (or "12 o'clock" position with a marked volume knob), that receiver/amplifier is now starting to work beyond its capabilities, sending harmful distortion that can damage any speaker, no matter how many watts that speaker is rated to accept. This is true for any speaker and receiver/amplifier combination. The recommended wattage to use on your new Klipsch CP speaker depends on which one you have:

CP-4: up to 50 watts continuous (for an extended period of time);
200 watt "peaks" (very short bursts/surges)
CP-6: up to 75 watts continuous (for an extended period of time);
300 watt "peaks" (very short bursts/surges)

HOOKING SPEAKERS UP TO AN AMPLIFIER/RECEIVER

When connecting speakers to an amplifier/receiver, always make sure speaker polarity is correct and the best sound is obtained by connecting amp/receiver positive (+) to speaker positive (+) and amp/receiver negative (-) to speaker negative (-). The CP speaker terminals are designed to accept up to 16 gauge wire.

One pair of Klipsch CP Series speakers, 8 Ohms, can connect to the left/right speaker terminals of any 8 Ohm rated amplifier/receiver as shown:

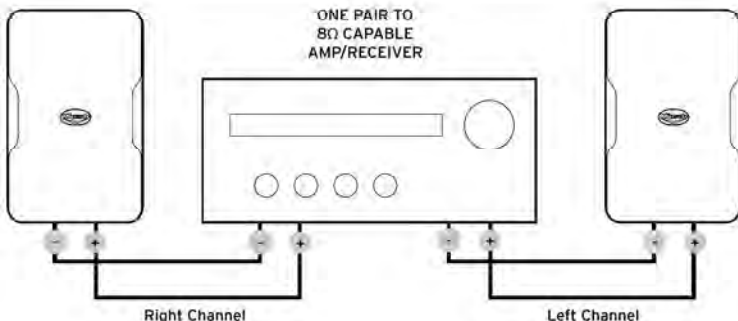

HOOKING SPEAKERS UP TO AN AMPLIFIER/RECEIVER (CONTINUED)

IF YOU WISH TO USE TWO PAIRS OF KLIPSCH CP SERIES SPEAKERS ON ONE AMPLIFIER/RECEIVER WE RECOMMEND ONE OF TWO METHODS:

Method 1 (Preferred): IF your amp/receiver has both A and B speaker terminals, connect one pair to A and one to B. Depending on your amp/receiver's capability you can then either play Speaker pairs A and B together or separately or Speaker pair A OR Speaker pair B only.

Method 2: IF YOUR AMP/RECEIVER IS RATED TO 4 OHMS OR LESS make a parallel wire connection as shown from the amp/receiver's right and left speaker terminals. Your amp/receiver may output more power to the speakers this way (check amp/receiver specifications).

OTHER POSSIBLE SPEAKER CONNECTION OPTIONS:

Series Wiring of Two Pairs to one Amp/Receiver: Instead of a parallel connection using a series connection as shown has the amp/receiver work at 16 Ohms but this cuts the power going to each of the speakers usually in half.

If you are using a surround (7/9/11 channel) receiver that receiver MIGHT allow connection of an additional pair of speakers to unused surround channels for use in a different listening area or may have a "Zone 2" capability to connect those speakers (check your receiver manual)

Using an outboard speaker switcher: Several types of available selector boxes allow hookup of multiple pairs of speakers to one amplifier/receiver and allow switching between them. Some models allow simultaneous play of two pairs of speakers. (see your audio dealer for availability).

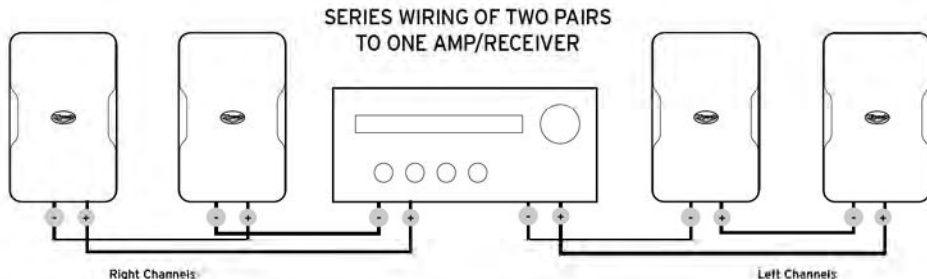
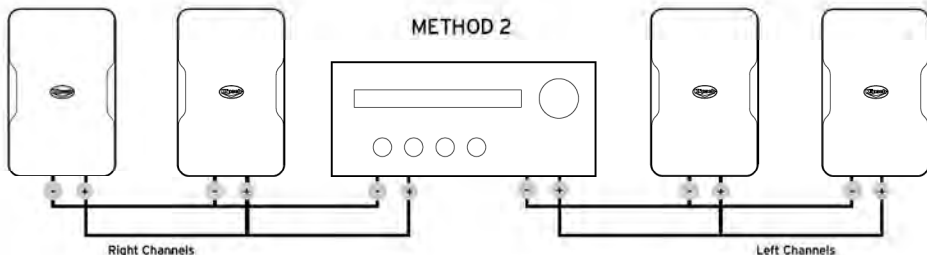
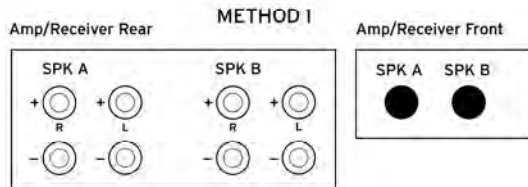

SUGGESTED SPEAKER PLACEMENT

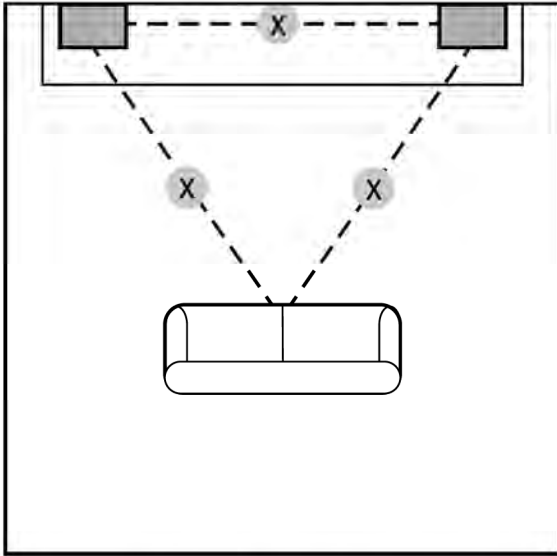

STEREO ROOM PLACEMENT EXAMPLE

Speakers same distance apart(X) as their distance to main listening position

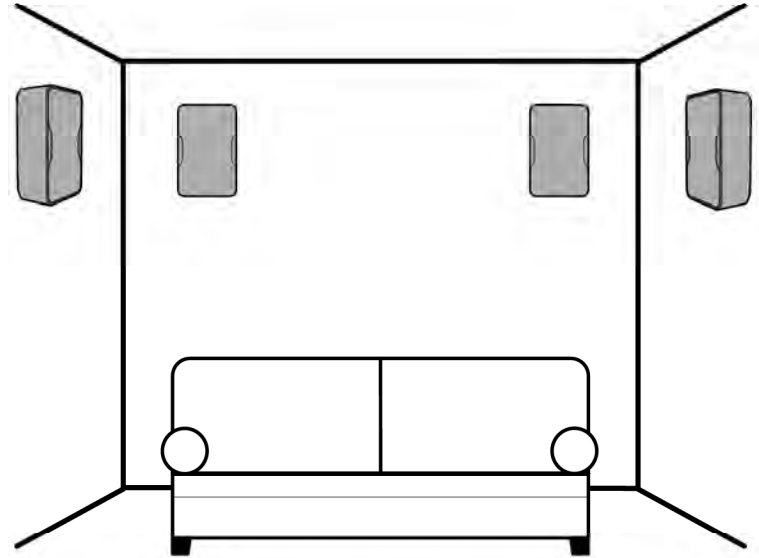

AS SURROUND SPEAKERS ROOM PLACEMENT EXAMPLE

5.1 surround: 2 side speakers
7.1 surround: 2 side/2 rear speakers
(all speaker 5-6' (1.5 - 2m) above floor)

SUGGESTED SPEAKER PLACEMENT (CONTINUED)

If speakers are covering a very large listening area (i.e. large patio/deck) you may be able to send a mono signal (L+R channel) to both speakers so that all listeners hear everything even if far from one speaker. See amplifier/receiver manual to see if it allows this.

(It is recommended when mounting CP speakers outdoors to shield them from direct rain, etc. by mounting under eaves or another type of cover.)

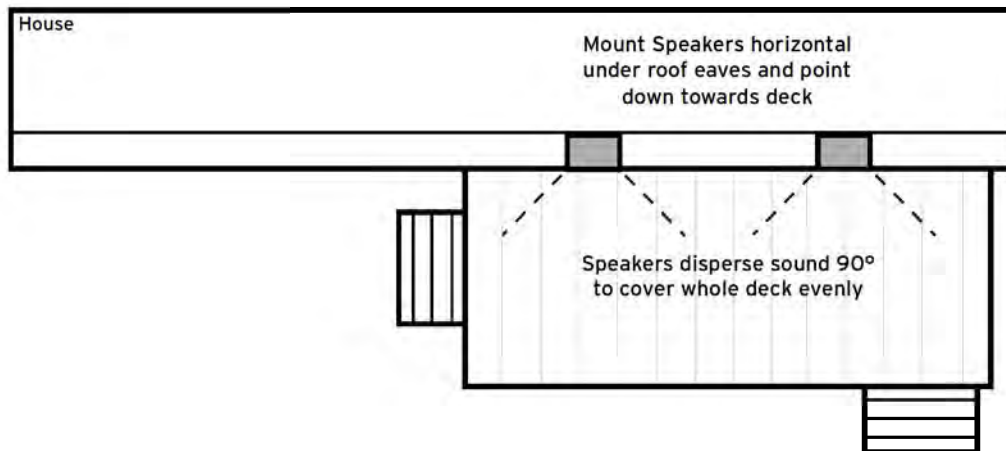

Other Mounting/Placement Tips:

- Mounting a speaker in a corner or wall/ceiling corner will increase its bass response and loudness make sure a speaker is not mounted/placed where an obstruction is in front of it that blocks sound
- Aiming a speaker at the main listening area reduces reflections from walls/ceilings and improves sound quality
- When covering a large area such as a deck or patio, you can send a mono signal (left + right channel) if your amp/receiver allows through each speaker instead of stereo so if listeners are spread out they hear all of the music.

CP SERIES

Thank you for your purchase of the Klipsch CP Series speakers! They are designed to both withstand the rigors of outdoor use while also complimenting any indoor décor as either a stereo pair or surround speakers in a home Theater system. The included, unique wall bracket provides for easy horizontal or vertical wall-mounting and even allows for a tight mounting tucked into a corner for a highly aesthetic look that also adds bass output. Shelf or table placement is an added option. The exclusive Klipsch 90°x 90° Tractrix® Horn not only provides controlled coverage, reducing

reflected sound which harms overall sound quality, but also gives you more sound output from the same amount of power input compared to other designs. The long-throw woofers are combined with front-firing ports for tight, musical bass no matter how they are mounted or placed.

WHAT'S INSIDE

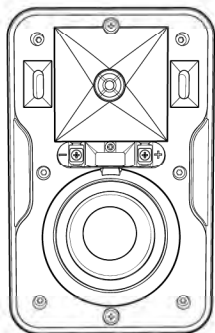

Speakers (x2)

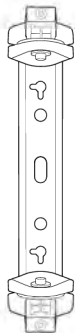

Brackets (x2)

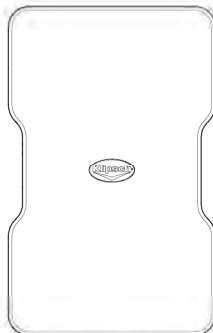

Grills (x2)



Bracket Retaining
Screws (x4)



Mounting Template



Grill Remover Tool

SPEAKER DIMENSIONS WITH/WITHOUT INCLUDED BRACKETS

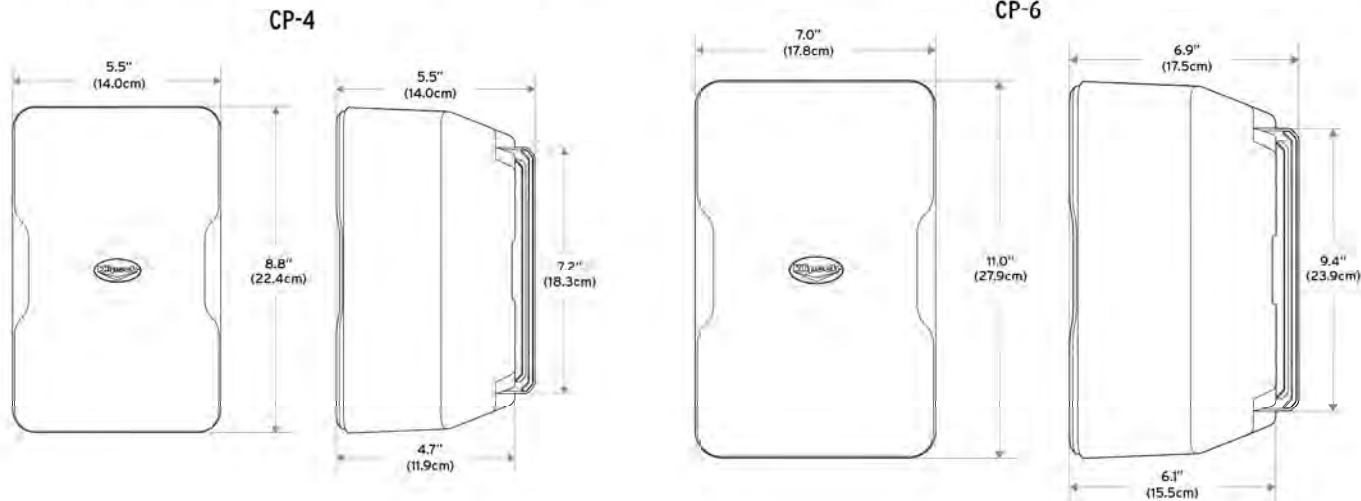

BEFORE SPEAKER INSTALLATION/CONNECTION

If wall mounting speakers, run speaker wire behind wall to mounting spots (if desired)

If wall-mounting with brackets you will also need:

- a) A level
- b) A pencil
- c) A Philips screwdriver (#2 size)
- d) Two #10 or #12 2.5-3 inch (4-5cm) Pan Head Screws for mounting into wall stud OR minimum 10 lb. (5 kg) Wall Anchors for mounting if stud unavailable

STEP 1

Typical Wall-Mounting With Included Bracket (Level not included)

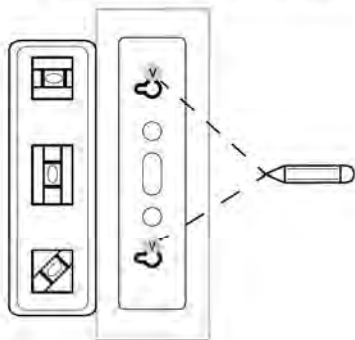

OR

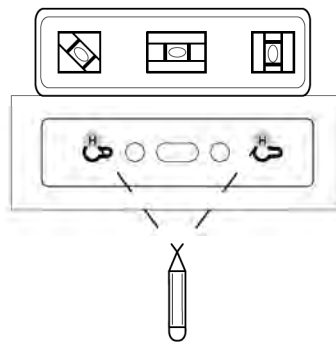

If Wall/Wall Corner or Ceiling/Wall Corner Mounting With Included Bracket

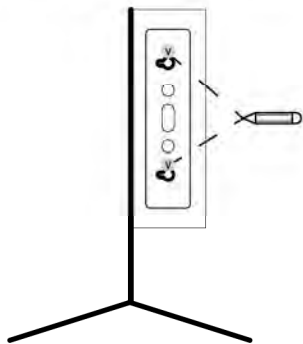

OR

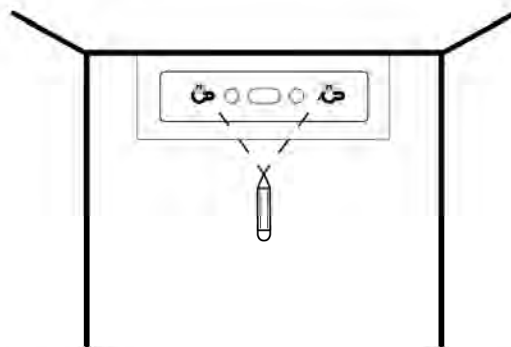

Choose speaker location and run speaker wire to location. Use included template and a level to mark bracket hole locations where speaker will be mounted.

STEP 2

Remove rubber terminal cover on speaker front and push speaker wire through middle channel on speaker back until pushed through speaker front where cover was.

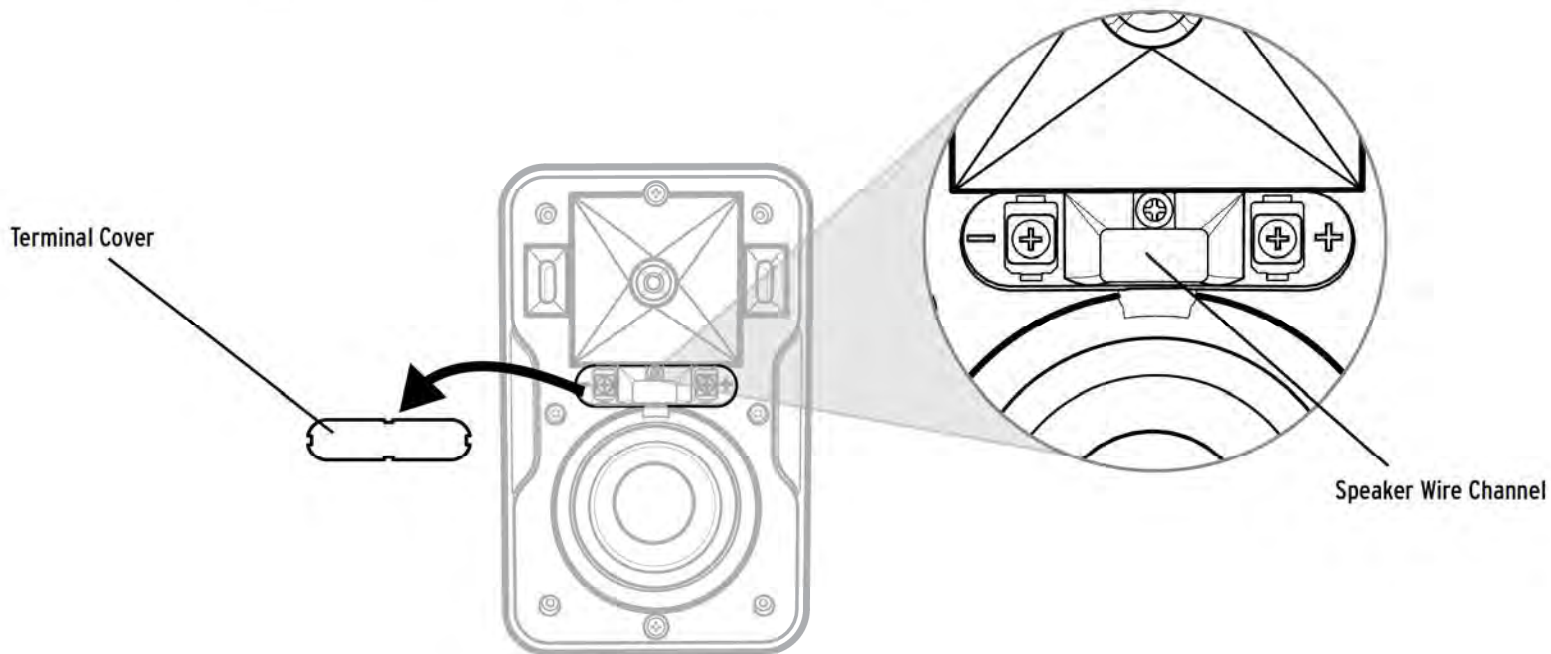

STEP 2 (CONTINUED)

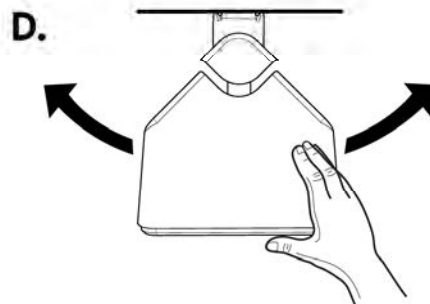
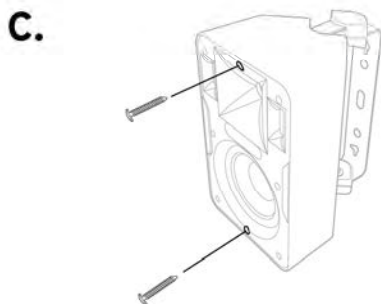
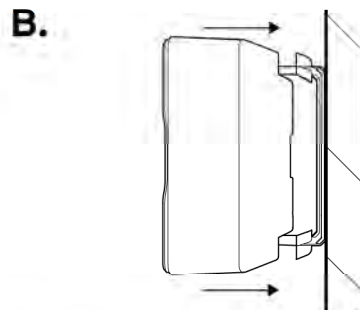
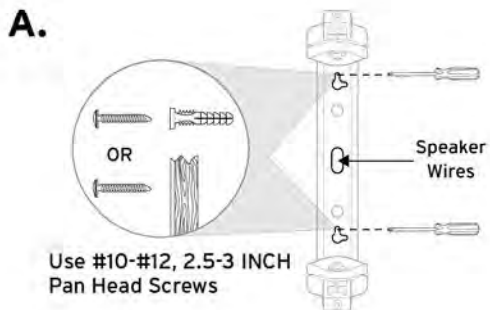

IF USING SUPPLIED BRACKET

- A. Run speaker wire through hole in bracket back and attach wall bracket to wall
- B. Slide speaker partially onto bracket arms and channel wire from back to front

- C. To keep speaker on bracket while adjusting use Phillips head screwdriver and partially screw in front top/bottom bracket screws (2-3 revolutions) then gently pull out speaker to detente position 3/4ths of way on bracket.
- D. WITH SPEAKER STILL PULLED OUT TO FIRST "STOP" POSITION ON BRACKET adjust speaker to desired angle on wall.

MOUNTING OPTIONS



OR

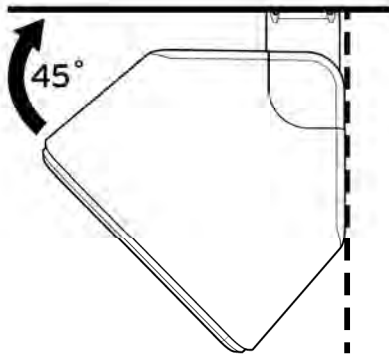

OR

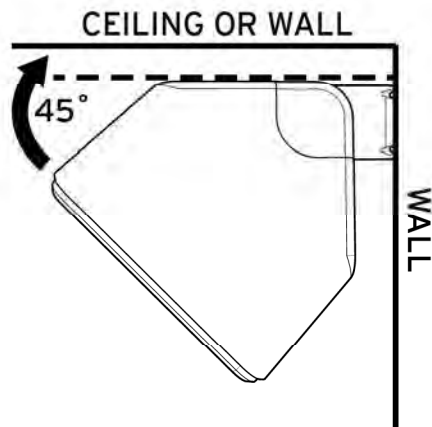
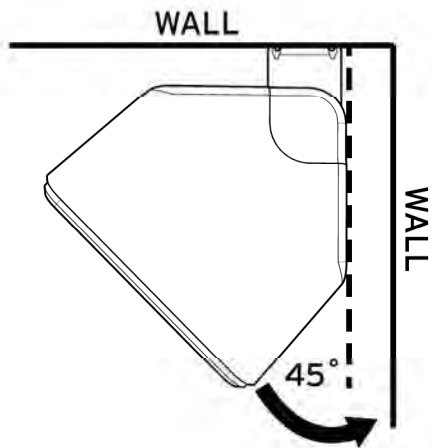
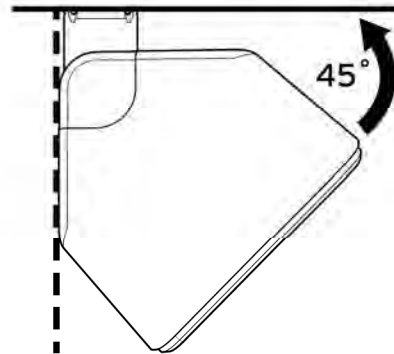

STEP 3

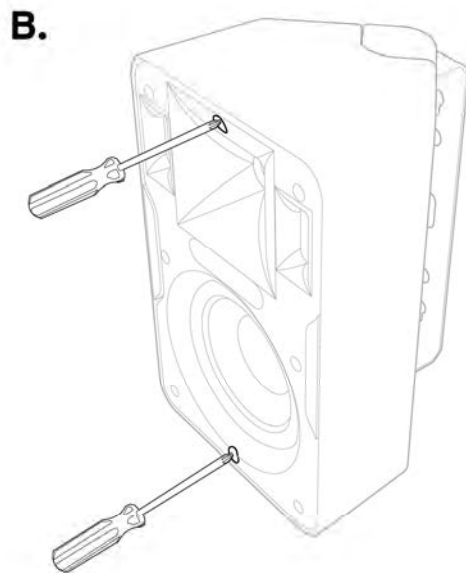
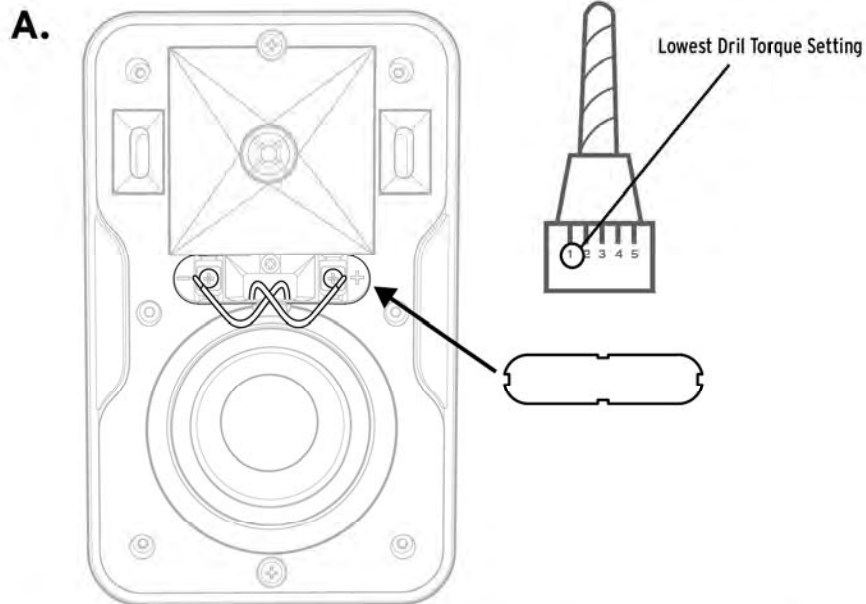

A. Connect Speaker Wires to Speaker Terminals with screwdriver or DRILL SET ON LOWEST TORQUE SETTING WITH #2 PHILIPS SCREWDRIVER BIT. Observe the correct polarity. Usually, red wire is positive (+) and black is negative (-). It does not matter which wire is connected to the positive or negative terminal as long as the connections are consistent on all speakers in the same system. Make sure both wires are pushed inside slot and replace terminal cover.

IF USING SUPPLIED BRACKET

B. Once speaker is positioned as desired push back all the way back on bracket arms until flush with bracket caps and screw two inserted screws all the way in to lock position.

STEP 4

TEST SOUND: Play music through speaker to make sure connections are tight and polarity is correct

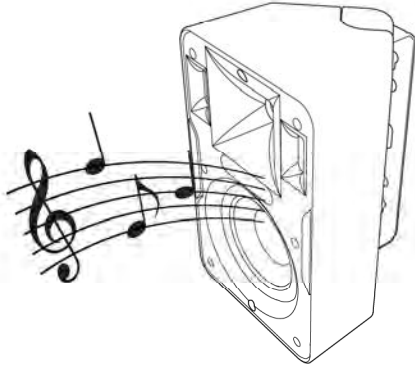

STEP 5

Once speaker is in the final position and tested, attach grill by pressing grill into channel encircling speaker front

***SPEAKER GRILL REMOVAL:** Use included grill removal tool, insert into a top corner and gently pull out. Repeat on a corner next to first one pulled, then pull out grill gently with hand. **NOTE:** the grill is designed to fit snug on speaker to both remain on and to remain tight. Continued removal/reinsertion of grill may make it loose and subject to either vibration or slippage.

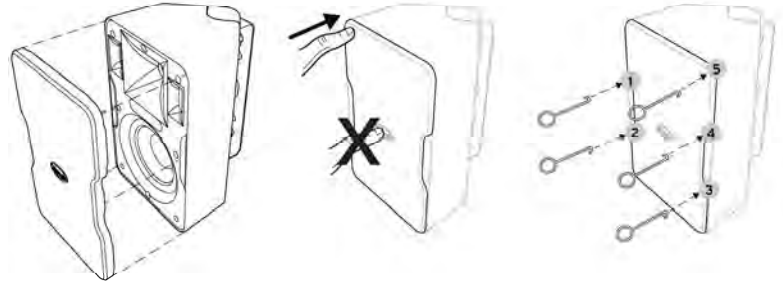

USING DIFFERENT MOUNTING BRACKETS

All CP Series speakers have a 1/4", 20-thread insert on the back bottom that you can attach a different, compatible mount.

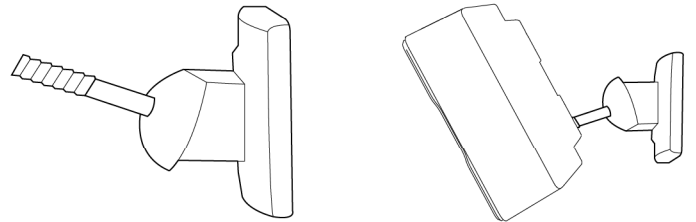

PAINTING THE SPEAKERS

Paint speaker and bracket top/
bottom caps separately.

1. First, clean speaker cabinet and bracket top/bottom caps with mild solvent or mild detergent/water
2. Then create a paint mask for speaker front (baffle) by tracing speaker grill on sheet of thicker, non-porous paper then cutting paper around tracing.
3. Place grill paper mask on front of speaker (over baffle) making sure to also cover grill channel; secure with double sided tape. Do not put tape on woofer. Mask around bracket top/bottom caps making sure not to paint bracket arm and swivel mechanism. Mask logo on grill front.
4. Use a spray paint that is made for plastic and spray speaker cabinet, bracket caps and grill front. Make sure not to cover grill holes. Allow all parts to dry before re-assembling speaker.

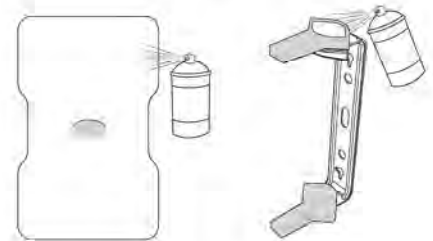
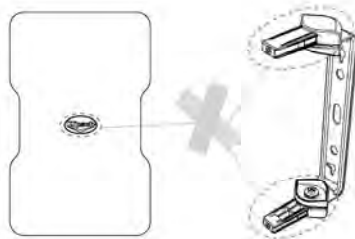
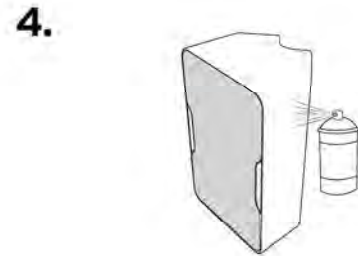
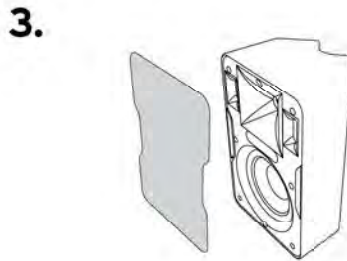
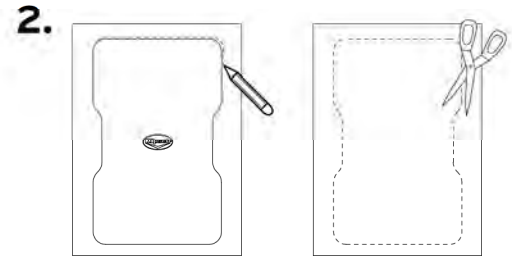

CP-4 SPECIFICATIONS

FREQUENCY RESPONSE ¹	80Hz-22kHz +3/-6 dB
POWER HANDLING ²	50 w (200 peak)
SENSITIVITY ³	91 dB @ 1 watt/1 meter
NOMINAL IMPEDANCE	8 ohms
TWEETER	.75" (1.9cm) aluminum dome tweeter
HIGH FREQUENCY HORN	90° x 90° Tractrix® Horn
WOOFER	3.5" (8.9cm) long-throw IMG woofer
CROSSOVER FREQUENCY	3.2kHz 12dB octave
ENCLOSURE TYPE	Bass-reflex via dual front-firing ports
WEIGHT	4.8 lbs. (2.2kg)
DIMENSIONS	8.8"(22.4cm) H x 5.5"(14.0cm) W x 4.7"(11.9cm) D
DIMENSIONS WITH WALL MOUNT	8.8"(22.4cm) H x 5.5"(14.0cm) W x 5.5"(14.0cm) D
FINISHES	White/Black enclosure and grill
WIRE GAUGE ACCOMMODATED	16
BUILT FROM	2014

¹ 3M anechoic

² IEC 268-5 filtered pink noise with 6dB crest factor

³ SPL at 1M, anechoic with 2.83V input

CP-6 SPECIFICATIONS

FREQUENCY RESPONSE ¹	70Hz-22kHz +3/-6 dB
POWER HANDLING ²	75 w (300 peak)
SENSITIVITY ³	94 dB @ 1 watt/1 meter
NOMINAL IMPEDANCE	8 ohms
TWEETER	.75" (1.9cm) aluminum dome tweeter
HIGH FREQUENCY HORN	90° x 90° Tractrix® Horn
WOOFER	5.25" (13.3cm) long-throw IMG woofer
CROSSOVER FREQUENCY	3kHz 12dB octave
ENCLOSURE TYPE	Bass-reflex via dual front-firing ports
WEIGHT	5.8 lbs. (2.6kg)
DIMENSIONS	11.0"(27.9cm) H x 7.0"(17.8cm) W x 6.1"(15.5cm) D
DIMENSIONS WITH WALL MOUNT	11.0"(27.9cm) H x 7.0"(17.8cm) W x 6.9"(17.5cm) D
FINISHES	White/Black enclosure and grill
WIRE GAUGE ACCOMMODATED	16
BUILT FROM	2014

¹ 3M anechoic

² IEC 268-5 filtered pink noise with 6dB crest factor

³ SPL at 1M, anechoic with 2.83V input



Scan the QR Code to view the Klipsch CP Series Owner's Manual in all languages.

OR

GR - Handbuch in Deutsch: klipsch.com/cpmanual
PR - Manual em Português: klipsch.com/cpmanual
IT - Manuale in Italiano: klipsch.com/cpmanual

Klipsch®

KEEPERS OF THE SOUND™

3502 WOODVIEW TRACE, INDIANAPOLIS, IN, USA

KLIPSCH.COM