

MILLER & KREISEL® S300 SERIES

**DIGITAL
CINEMA**

**AVAILABLE AT
DIGITAL CINEMA**

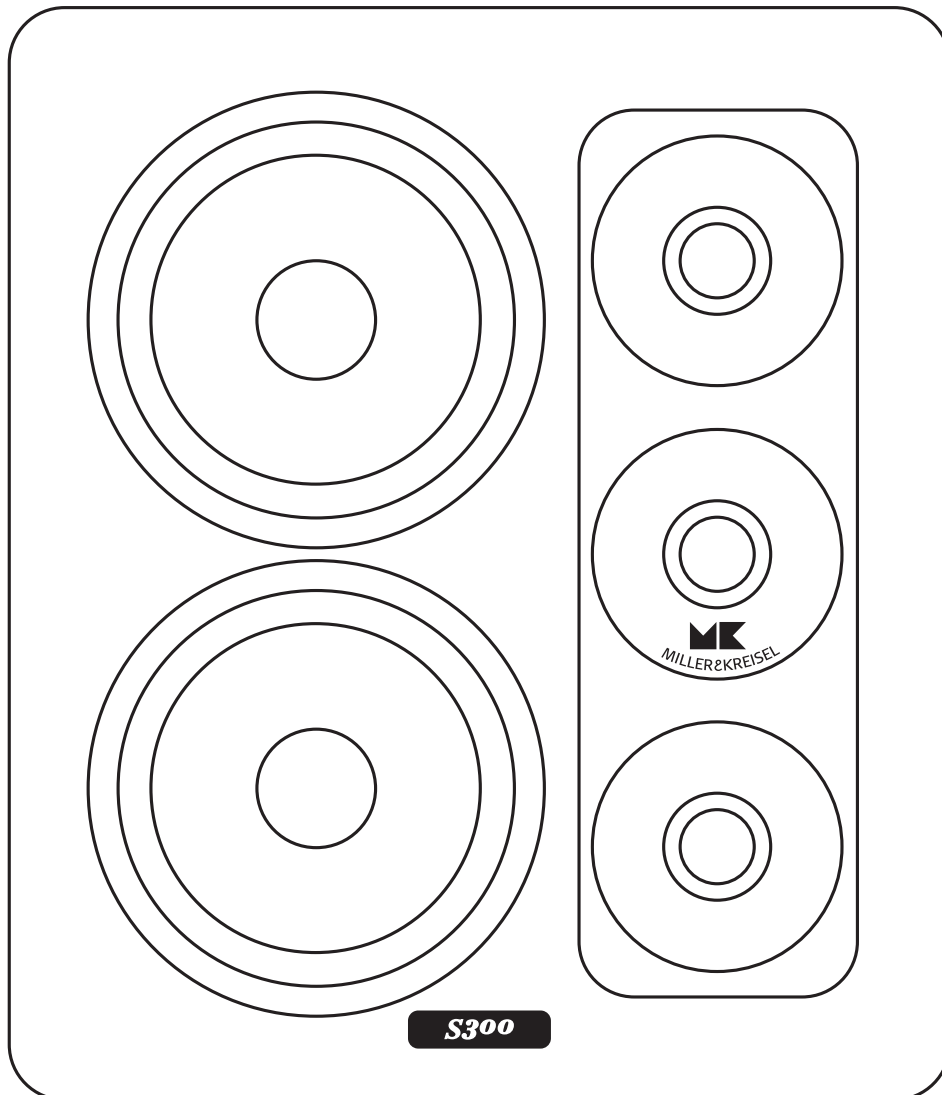

THE WHITE PAPER

MILLER & KREISEL[®]

S300 SERIES



Introduction

After inventing the subwoofer in 1973 for use in the mixing of the classic Steely Dan LP Pretzel Logic and re-inventing it more recently with the acclaimed X Series, we at M&K Sound knew that the time was right to raise the stakes once again with an all-new top of the range series carrying our new reference logo Miller & Kreisel

Designed and assembled in Denmark, the birthplace of the dynamic drive unit and of the acoustic sciences, the S300 Series takes compact reference satellite monitor power handling, dimensionality and resolution to new heights.

The satellite/subwoofer configuration pioneered by M&K Sound and refined over the past 40 years allows the main speakers to be more compact, making high performance audio available with a far less space-consuming profile.

As a company founded on professional music and film recording and High End home entertainment, the goal for all M&K Sound design work down through the years has always been accurate and realistic reproduction of whatever the microphones capture.

*As an utterly neutral conduit, the S300 Series neither adds nor subtracts. It simply **reveals**.*

M&K Sound are used by the world's finest filmmakers, including:

- Warner Bros
- 20th Century Fox
- Universal
- Paramount
- Dreamworks
- HBO
- Skywalker Sound
- Disney
- THX
- DTS
- Dolby Labs
- Sony Music
- Lucas Film





THX Certification

The Miller & Kreisel S300 loudspeaker system has been subjected to rigorous impartial testing and certified to meet the highest industry performance standard: THX Ultra2.

THX is a set of performance standards originally developed by Lucasfilm Ltd. in connection with the premiere of Star Wars Return of the Jedi in 1983 to establish criteria to ensure that the creations of cinematic artists are reproduced exactly as intended. The THX logo immediately became recognized as a seal of approval for quality-conscious cinema-goers around the world. In 1991, M&K Sound became one of the first manufacturers to join George Lucas and his Lucasfilm Home THX program for domestic installations.

Today, THX is the highest independent quality standard dedicated to the accurate reproduction of audio sources in the home. THX certification attests that the component has been thoroughly evaluated by a fully independent body and found to live up to the strictest quality requirements in the audio industry.

"We are impressed with performance of the new THX Ultra2 certified M&K Sound S300. It is evident that a lot of attention was paid to the design and component selection of this product and this effort shows the systems ability to deliver smooth response with high output and very low distortion".

- Mike del Santo, THX testing manager



Proprietary Crossover Concept

M&K Sound's proprietary Phase-Focused crossover networks make the S300 Series ideal for both music and movies without compromise. Seamless integration of the two driver arrays is achieved with an 4th order roll-off of the mid/bass section (24 dB per octave) as the tweeter array is controlled by a 2nd order filter (12 dB per octave). The tweeter section incorporates effective phase correcting circuitry for resonance control to minimize system impedance variation and maintain minimal phase shift across the total system bandwidth.

The transient-optimized crossovers incorporate audiophile-grade components including high-

power polypropylene capacitors with thick copper wire connections and costly distortion-less air-core inductors wound from 1.2 mm high-purity copper for virtually flat frequency response with ideal phase characteristics. Based on crossover components carefully selected for extremely tight performance tolerances and high power handling, any S300 model is a fine partner for virtually any amplifier.

Wide horizontal directivity provides even coverage of the listening area, while controlled vertical directivity reduces reflections off the floor, ceiling, tables, etc. By significantly reducing reflected sound, image specificity, localization and dialog intelligibility are vastly improved.

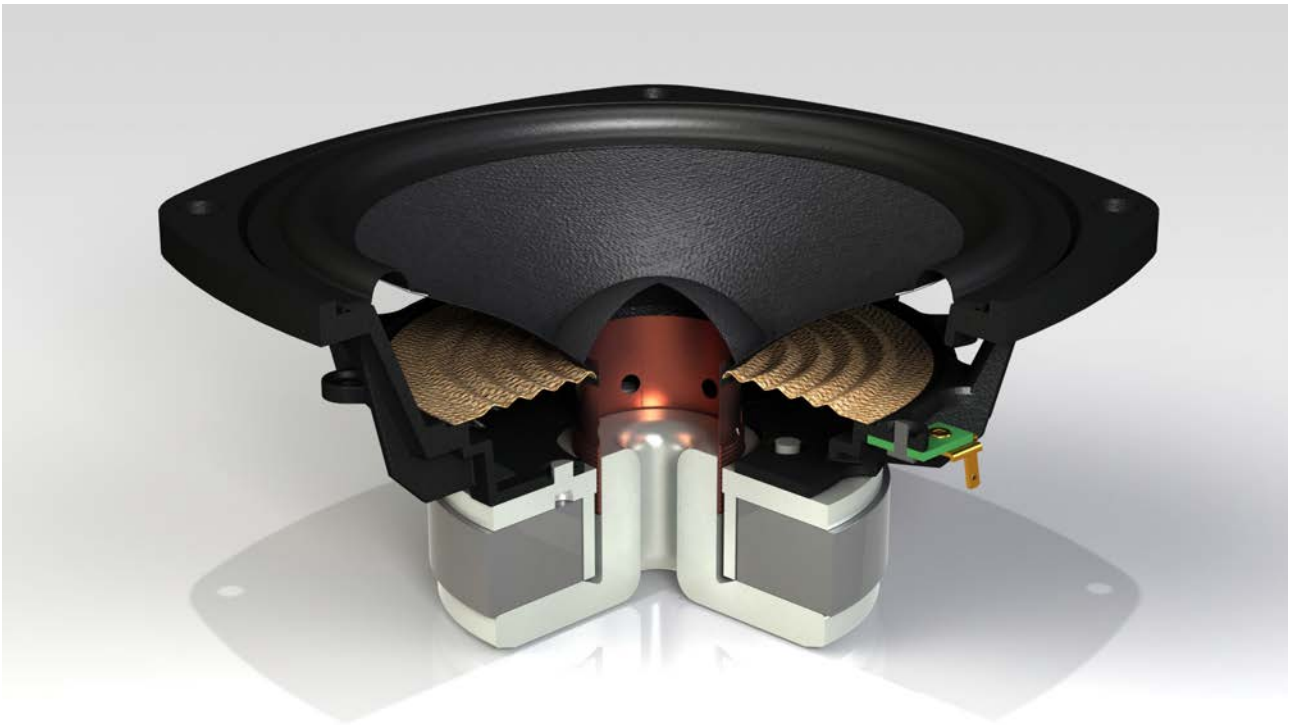

Innovative Danish Driver Design

M&K Sound's engineers have decades of experience in the design of individual drivers as well as complete loudspeaker systems. Because we are fully conversant in the languages of both the acoustical engineer and the audiophile music lover, M&K Sound can enter into a mutually beneficial collaboration with the world's most acclaimed makers of drive units.

Aerodynamic air flow design is the watchword for the new generation of drive units designed and built ex-

clusively for the Miller & Kreisel S300 Series to ensure pure, high definition sound with extraordinary speed and transient control.

S300 drivers are built to M&K Sound's exacting specifications by Scan Speak of Denmark, with a forty-year history of ground-breaking innovation and multiple patents for breakthroughs in every aspect of driver design.



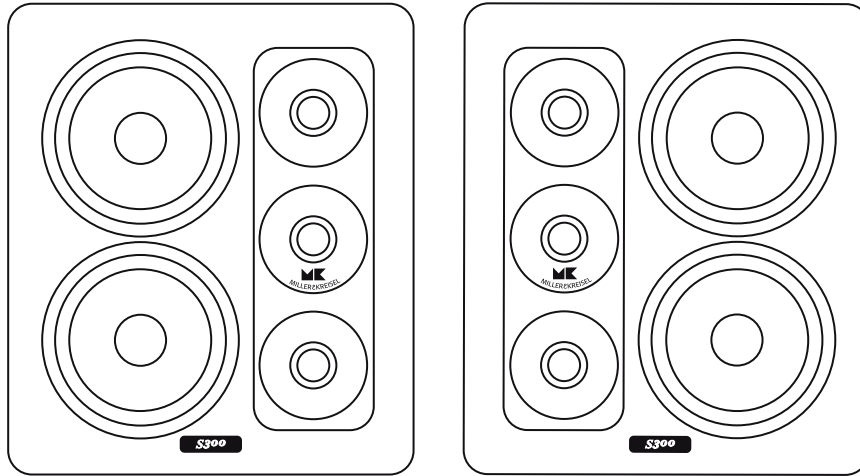

Iconic Driver Layout with Innovative Internal Bracket Mounting

The iconic front baffle layout of the famed S150 monitor with its triple-tweeter array alongside dual woofers is also an integral aspect of the design and performance of the S300.

The S300 Series introduces specially designed separate tweeter and woofer mounting brackets for exceptional mechanical isolation from the cabinet and a tight connection between the die-cast, custom made brackets and the front baffle.

All drivers are rear mounted to the brackets and the brackets are rear-mounted to the baffle for an elegant front with no unsightly screws and no reflective edges near the drivers. This effectively eliminates a major source of coloration in more conventional, less conscientiously designed loudspeakers.

Acoustic Alignment

With the mid/woofers slightly recessed in the baffle and each tweeter mounted in a carefully calculated waveguide, the acoustic centers of all drivers can be precisely aligned for ideal phase/time relationships to deliver the flawless timing that has always been a hallmark of M&K Sound..

The demanding 1.5 KHz crossover point and precise

driver positioning are critical to the achievement of fast, accurate audio reproduction. Optimal performance in this area requires correct definition of the acoustic centers of the tweeters and woofers, near the voice coil/dome assembly in the tweeter and further forward, closer to the surround for the woofer.

Positioning the drivers accordingly synchronizes the sound from both drivers for enhanced timing and exceptional rendering of fine detail.

The low crossover point requirements of larger component values minimize electrical phase delay further contributing to seamless timing of the two arrays.

The dual woofers are mounted with in the baffle with no reflective edges to eliminate reflections and resonance peaks.

The drive units in each triple tweeter array are carefully measured and matched prior to mounting. Employing three tweeters allows significantly increased power handling, reducing the load on each individual driver and making it possible for the system to operate optimally at a lower crossover point and with minimal phase shift.

The Benefits of the Triple-Tweeter Array

It is a well known fact that a solo tweeter in a system, regardless of its quality, will tend to sound and behave like a point source. Most tweeter designs display identical dispersion characteristics in all directions unlike cone drivers and tend to lose energy when measured and listened to in off-axis positions.

As we move further away from the “sweet spot” on-axis listening position with a single tweeter, the highest frequencies will begin to show early roll-off, as an inevitable result of the natural behavior of a conventional dome tweeter.

This does not necessarily mean that a system with a single tweeter cannot perform well or for that matter measure respectably off-axis.

Fitting a dome with a properly designed wave guides is the best way to ensure improved dispersion linearity, so that the level of high frequency roll-off remains more linear relative to on-axis response, resulting in constant directivity characteristics, instead of a more horn-loaded character, with significantly varying on and off axis characteristics.

In a fully realized vertical tweeter array, waveguide design is a key element. The goal of a triple-tweeter configuration is to merge in the creation of a wide horizontal listening window, while at the same time controlling vertical directivity in order to prevent reflected sound from the ceiling and floor from reaching the listening position. Uniform sound dispersion in the horizontal plane is crucial to the reproduction of the stereo image and soundstage depth.



The selection of the tweeter array configuration completely re-defines the starting point for overall system design.

1. With three tweeters connected in parallel, the power load on each tweeter is reduced to 1/3, so that at any given peak in the program material, the displacement of each dome will only be 1/3 of a single tweeter – resulting in significantly reduced distortion.

2. With reduced dome motion, it becomes possible to implement a lower crossover point. With each tweeter handling 1/3 of the total power load, the risk of tweeter damage is reduced

significantly, despite the fact that the combined array handles increased power due to the lower crossover point.

3. The low crossover point provides smoother integration with the mid/woofers, because of the more consistent dispersion characteristics of a tweeter at the lower end of its frequency range. The triple stacked tweeter configuration operates as a single unit, well suited to greater power handling and a smooth transition to the mid/woofers.

4. As a direct advantage of the lower crossover point, the tweeter array acts as a single unit acoustically, with virtually no phase shift near the tweeter’s resonance frequency and crossover point.

5. Placing multiple tweeters close together can normally be a problem, due to frequency interference (lobing) caused by the shorter wavelengths of high frequencies. Often, this will cause irregular frequency response variations, which no serious speaker

designer should accept. The S300 tweeter array solves this issue by using two high-impedance tweeters (top and bottom), combined with one lower impedance tweeter, pre-matching output levels prior to the overall level adjustment that takes place in the phase-focused crossover. A specially designed circuit fine-tunes the now integrated triple tweeter configuration, allowing to operate acoustically as a single unit.

With three dome tweeters stacked to form a finely tuned system – the overall tweeter system can be optimally integrated with the mid/woofers. The vertical stacking of tweeters results in large surface area for reduced pin-point dispersion character. Vertical dispersion is reduced - while the horizontal dispersion now shared by three tweeters is much wider and more uniform at the height of tweeter array.

Reduced/controlled vertical dispersion and enhanced horizontal dispersion are critical in generating a larger sweet spot, while the vertical dispersion is controlled to minimize reflections from ceiling and floor at the listening position.

The faceplate wave guide is especially designed for flush-mounting and the waveguide horn-loading of each driver ensure more consistent high-frequency response both on-axis and off-axis.



Bolted to the inside of the front baffle, the thick flanges of the faceplate contribute enhanced rigidity and an ideal vibration-free environment for the three individually bolted drivers.

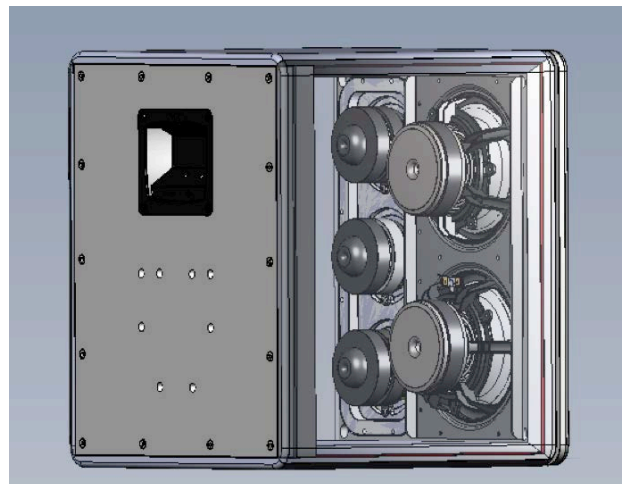

Dual 6.5" mid/woofers move air with a surface area greater than that of a single 9" woofer, but with far greater speed, precision, dynamic agility and power handling, because two separate cones and motor systems sharing the load run cooler and smoother.

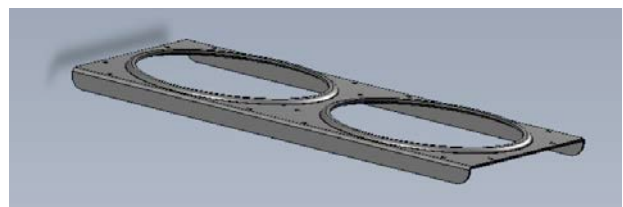

Mounted in a steel bracket, the mid/bass units are fitted flush to the front baffle for a solid, non-resonant connection with only the cone surface exposed.

S300 1" Soft Dome High Frequency tweeter

Even at low levels, a dome causes compression of the captive air mass within. The S300 tweeter ventilation system is designed to ensure that there is no air mass loading the dome and to achieve extended frequency response for a smooth transition to the mid/bass unit. The Miller & Kreisel aerodynamic air flow control damping system offers an effective solution (see 1, 4 and 11.).

1. The rear chamber provides effective control of impedance, resonance and compression.

2/6. Dual magnets form an extremely powerful magnetic system with effective control of stray magnetic fields.

3. The rear chamber is filled with highly absorbent damping material for controlled air flow.

4. The precisely positioned pole flow resistor between the rear chamber and felt pad carrier prevents any captive air mass in the vented pole, so that there is no undesirable loading of the dome. Without the pole flow resistor in place, the dome would be loaded by a captive air mass, restricting the driver's downward frequency extension and necessitating extensive compensation in the crossover network.

5. T-yoke with aerodynamic vented pole structure and conical lower half optimizes air flow/heat dissipation, eliminating standing waves behind dome.

7. The multi-purpose copper ring mounted directly in the motor system air gap eliminates 2nd order harmonic distortion, reduces intermodulation distortion by separating the voice coil's stray field from the permanent magnet system's field and contributes

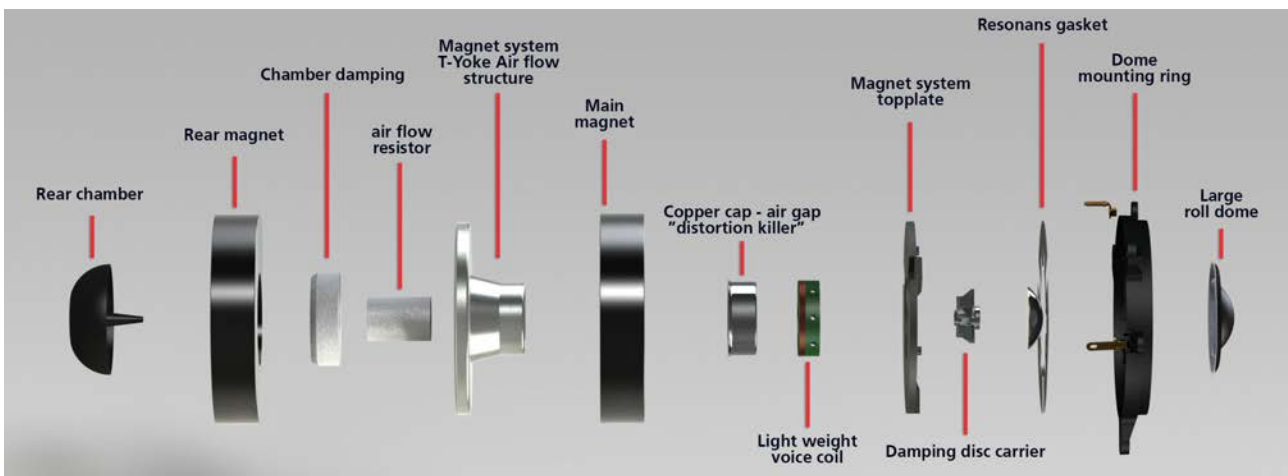

to the loudspeaker's linear impedance and linear phase by reducing the voice coil's natural inductance.

8. Vented aluminum voice coil and copper-clad aluminum wiring ensures fast response and efficient heat dissipation for high power handling. With the voice coil suspended in low-viscosity ferrofluid for enhanced heat dissipation, the S300 tweeter delivers higher power handling with reduced power compression.

9. The precision punched steel top plate covers magnet system.

10. The carrier keeps the felt pad precisely positioned relative to the dome, while still allowing air to pass around and access the larger cavities through the magnet system's vented pole piece and down to the rear chamber.

11. The highly absorbent felt air flow resistor pad prevents reflected sound (rear loaded resonances) from returning to the dome.

12. Assembly gasket ring eliminates resonances between motor system and dome assembly mounting ring.

13. Dome assembly mounting ring ensures precision mating of all parts.

14. Dual polymer (silk and polyester) coated dome with large suspension roll achieves ultra- fast transient response for extraordinary clarity and accuracy.



S300 6.5" Woofer

1. Soft steel T-yoke with vented pole piece minimizes compression and distortion and evacuates captive air mass behind dust cap for fast transient response and minimal compression at large excursion. Flared edges eliminate "turbulence" around the vents, further reducing compression.

2. Aluminum shorting ring "distortion killer" eliminates 2nd harmonic distortion normally caused by the stray magnetic field generated by a voice coil,

especially at large excursion. The ring also reduces voice coil induction for more ideal impedance linearity.

3. Permanent magnet of high-grade strontium ferrite ensures extreme thermal stability.

4. Top plate of soft steel with precision stamped opening maintains tight tolerances for high power potential at the coil. Tight tolerances ensure full control of the driver's damping factor.



5. Miller & Kreisel custom made aluminum basket employs open frame (7 mm flange) with rigid rib structure for mechanical stability and full ventilation under the spider and cone to eliminate power compression and drastically reduce 3rd harmonic distortion.

6. Ultra-linear spider of Conex (compound of cotton and heat-resistant polyfibers) contributes to lightning-fast transient response based on large diameter and multiple soft shaped rolls for free movement with minimal internal progressive resistance. The spider exhibits linear characteristics regardless of excursion, while maintaining full control over voice coil motion.

7. Low mass, high conductance vented voice coil on non-inductive glassfiber former reduces distortion and minimizes compression under the dust cap for fast “high Q” transient response. Professional high-grade wire is employed for extreme thermal stability. Absolute linear travel up to ± 6 mm during transients is achieved with a 32 mm coil diameter and 14 mm coil length in a 5 mm gap.

8. Single-roll SBR rubber is optimized for minimal mass, for use in a sealed enclosure with complete control over cone motion. The low loss design achieves the greatest possible cone surface area to fully exploit available amplifier power.
(SBR = Synthetic Butyl Rubber)

9. Glassfiber cone with polymer coating ensures a smooth, controlled break-up pattern at higher frequencies. The hyperbolic curvature of the cone ensures that even the most miniscule motion of the voice coil is transferred to the cone without loss.

10. Small glassfiber dust cap minimizes reflections and break-up spikes at higher frequencies, providing added stiffness and strength due to its close proximity to the voice coil so that energy is transferred directly to the cone.

Triple-Layer Non-Resonant Enclosures

The Miller & Kreisel S300 Series employs a complex, box-inside-a-box construction with a non-resonant layer of tar joining the two cabinets to provide constrained layer damping. All six sides employ the same extremely rigid, highly damped sandwich construction. A stereo pair consists of mirror-image, dedicated left and right speakers for optimal imaging.

The Miller & Kreisel S300 Series achieves audibly superior results with thicker, denser panels utilizing constrained layer damping, i.e., laminating the exterior of the base layer (inner cabinet) with a damping layer of tar and then adding a third constraining layer (outer cabinet). The S300 constrained layer sandwich dissipates vibration by absorbing kinetic energy and converting it into low-grade frictional heat effectively and harmlessly.

At best, conventional speaker cabinets may incorporate some kind of damping material simply glued to one or more inner surfaces. This is known as extensional or free-layer damping and can be of some limited use in curbing vibration in thin panels.

Much of what is heard from most loudspeakers is actually unwanted sound produced by the cabinet as the panels resonate in response to the acoustic signal generated by the drivers. Vibrating cabinet walls, standing waves inside the cabinet, diffraction interference due



to reflections off the front baffle of the cabinet and vibrations transferred via the baffle from one driver to the others are major sources of uncontrolled, disruptive sound.

These disturbances slur, smear and conceal micro-details, essential low-level cues that help

our brains re-create the size and shape of the recorded space in three dimensions, the precise placement of voices and instruments and their distinctive timbres.

The loss of the subtlest nuances sucks the life out of music and movies, making it substantially more difficult for the audience to suspend disbelief and relax in a “you-are-there” experience.

These issues are eliminated in the Miller & Kreisel S300 Series with 9 mm inner panels and 12 mm outer panels joined by a 3 mm layer of tar to effectively eliminate vibration. Because of its high molecular density, a 3 mm layer of tar has energy absorbing properties roughly equivalent to adding a further 6 – 8 mm of MDF.

Tar and the two MDF panels of unequal thickness have different resonant characteristics that help dissipate resonances before they excite unwanted motion in the cabinet panels.

The M&K Sound design team experimented extensively with various materials with resonance-damping properties, including rubber, silicone rubber, PVC (Polyvinyl chloride) foam, PU (Polyurethane) foam, before determining that tar offers optimal acoustic and physical properties that will remain constant for many years.

The Miller & Kreisel S300 Series cabinet construction and specially designed drive units lower the mechanical noise floor drastically, bringing music and movies to life with effortless realism, building on a rock-solid foundation.

Innovative driver mounting techniques and the composite sandwich construction elevate the audio performance of the S300 to new levels.

Because all S300 Series loudspeakers are designed for use with a subwoofer, the absence of deep bass allows more compact enclosures that also contribute to their extreme structural integrity.

To prevent transfer of vibrations from the inner cabinet to the outer cabinet, no screws are used between the two boxes.

The smoothly beveled edges of the front baffle reduce diffraction interference and present a stylish face.

Behind the drivers, two carefully spaced sheets of Polyethylene Terephthalate (PET) are fitted for effective break-up of internal standing waves to eliminate sound passing through the mid/bass cones.

The Miller & Kreisel S300T tripole surround speaker employs independent, isolated chambers for each

driver. The surround features massive 6 drive units and the dual 4 inch side-mid ranges provides the unique ambience and makes the S300T a true tripole.

The acoustic characteristics of the side and front firing S300T drivers are carefully voiced to match the S300.

Employing the S300 woofer and tweeter on the front baffle, total system timbre matching and voicing closely matches the sound of the S300 front system.

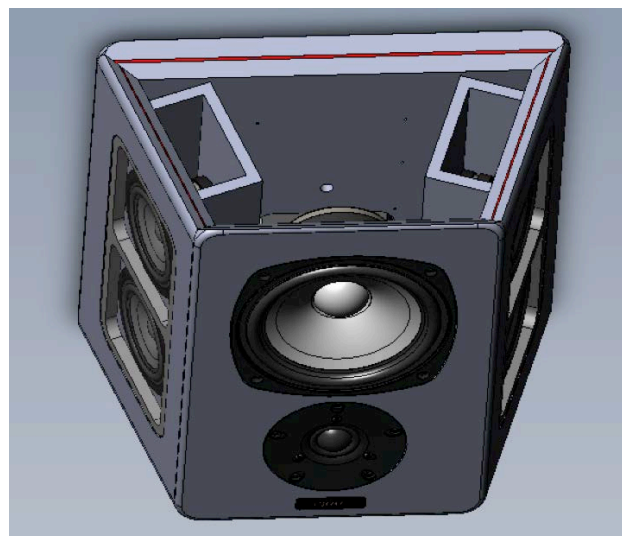

The dual sets of side-firing drivers 4 inch. incorporate a small network to ensure that the side drivers closest to the front tweeter do not interfere with the dispersion of the front firing tweeter.

The angled side panels allow the side drivers to blend seamlessly with the front drivers – for the perfect combination of diffuse and focused sound character that makes M&K tripoles unique.

The Miller & Kreisel S300 Series

The S300 Series employs sealed enclosures exclusively to avoid the boomy, muddy sound that is inevitable with bass reflex designs. Sealed enclosures are the only way to achieve the finest transient response, impulse response and frequency extension with the

control and authority that have made M&K Sound the Choice of Professionals for four decades.

The rear panel with terminals and crossover network is screw-mounted into an inset frame for a tight seal and firm connections.





S300 Monitor



The Miller & Kreisel S300 offers transparency and neutrality that surpasses far larger, more costly systems. More compact than any monitor capable of rendering such clarity and pinpoint detail, the ultra-smooth S300 ensures unsurpassed, effortless realism even in very large rooms.

While a dedicated left/right mirror-image pair provides optimal imaging for two-channel sources, the use of an identical third speaker for center channel duties guarantees a seamless, consistent soundfield in all dimensions.

Miller & Kreisel S300 is the ultimate demonstration of our dedication to innovation and quality.



MP300 On-Wall Monitor



Recognizing a growing demand for a high level of audio performance from an unobtrusive, decorator-friendly enclosure, M&K Sound offers a shallower, wall-mount version of the Miller & Kreisel S300.

By significantly reducing cabinet depth and revising overall dimensions to ensure no loss of internal volume, M&K Sound has created an elegant, discrete on-wall monitor that retains the audio quality of a full-size compact loudspeaker.

The modest dimensions and extended placement options of the MP300 will appeal to the style-conscious music/movie lover.



S300T Tripole



M&K Sound invented the tripole speaker configuration to do what no conventional monopole loudspeaker can. Side and/or rear mounted S300T's enhance the solidity and pin-point placement of rear channel events such as fly-overs, voices, effects, music, etc., as well as the realism of the ambient soundfield.

The S300T tripole, with Integral wall-mount bracket, employs the same front drivers and crossover technology as the S300 monitor for a perfect acoustic match. Independent, isolated side chambers house two 4" drivers per side for optimal surround coverage to rival the performance of the huge array of speakers required in movie theaters.

See last page 19 for detailed product specifications.

X Series Subwoofers

Combined with X Series Dual Drive Push Pull subwoofers, the S300 Series possesses the transparency, speed and resolution that let the most critical audio professionals hear exactly what's going on in the mix and allow them to listen for hours on end with no hint of fatigue. M&K Sound's seamless, integrated feel from top to bottom to immerse audiences in sound with exceptional handling of dynamic changes in pace and volume.

X8 Subwoofer

With dual 8" drive units, the X8 provides 100 sq. in. of cone area to move and control air, equivalent to a single 12" driver.



X10 Subwoofer

With dual 10" drive units, the X10 provides 156 sq. in. of cone area to move and control air, equivalent to a single 15" driver.



X12 Subwoofer

With dual 12" drive units, the X12 provides 226 sq. in. of cone area to move and control air or 40% more surface area than the X10 and 126% more surface area than the X8, equivalent to a single 18" driver. X10 and 126% more surface area than the X8.



"The X12 is among the best subwoofers available, equally suited to motion picture soundtracks and music."
Widescreen Review magazine (USA), January, 2014

"The low end extension of the X12 is astounding!"
www.hometheaterhifi.com February, 2014

"This is one of the best subwoofers I've ever heard in my room."
Sound & Vision magazine (USA), April, 2014

For full details on the Miller & Kreisel X Series subwoofers, please visit
www.mksound.com/whitepaper/x-series

Miller & Kreisel® S300 Series Specifications



S300

Impedance:	4 Ohm
Frequency Response:	60 Hz – 22 kHz, ±3dB
Crossover frequency	1.5 KHz
Sensitivity	93 dB
Maximum SPL	t.b.a
Recommended Power:	25 - 500 Watts
Finish:	Black Satin
Dimensions (HxWxD):	15.5 x 13.4 x 13.0" / 39.5 x 34.0 x 33.0 cm
Weight:	40.0 lb / 18.2 kg

S300T

Impedance:	4 Ohm
Frequency Response:	80 Hz – 22 kHz, ±3dB
Crossover frequency	1.8 KHz
Sensitivity	89 dB
Maximum SPL	t.b.a
Recommended Power:	25 - 400 Watts
Finish:	Black Satin or White Satin
Dimensions rear side (HxWxD):	13,5 x 13,5 x 7 inch / 34,5 x 34,5 x 18 cm
Dimensions front side (HxWxD):	13,5 x 8,8 x 7 inch / 34,5 x 22,5 x 18 cm
Weight:	26 lbs / 12 kg

MP300

Impedance:	4 Ohm
Frequency Response:	80 Hz – 22 kHz, ±3dB
Crossover frequency	1.5 KHz
Sensitivity	92 dB
Maximum SPL	t.b.a
Recommended Power:	25 - 500 Watts
Finish:	Black Satin or White Satin
Dimensions top (HxWxD):	15.5 x 13.4 x 6,3 inch / 39.5 x 34 x 16 cm
Dimensions bottom (HxWxD):	15,5 x 13,4 x 4,7 inch / 39,5 x 34 x 12 cm
Weight:	26 lbs / 12 kg

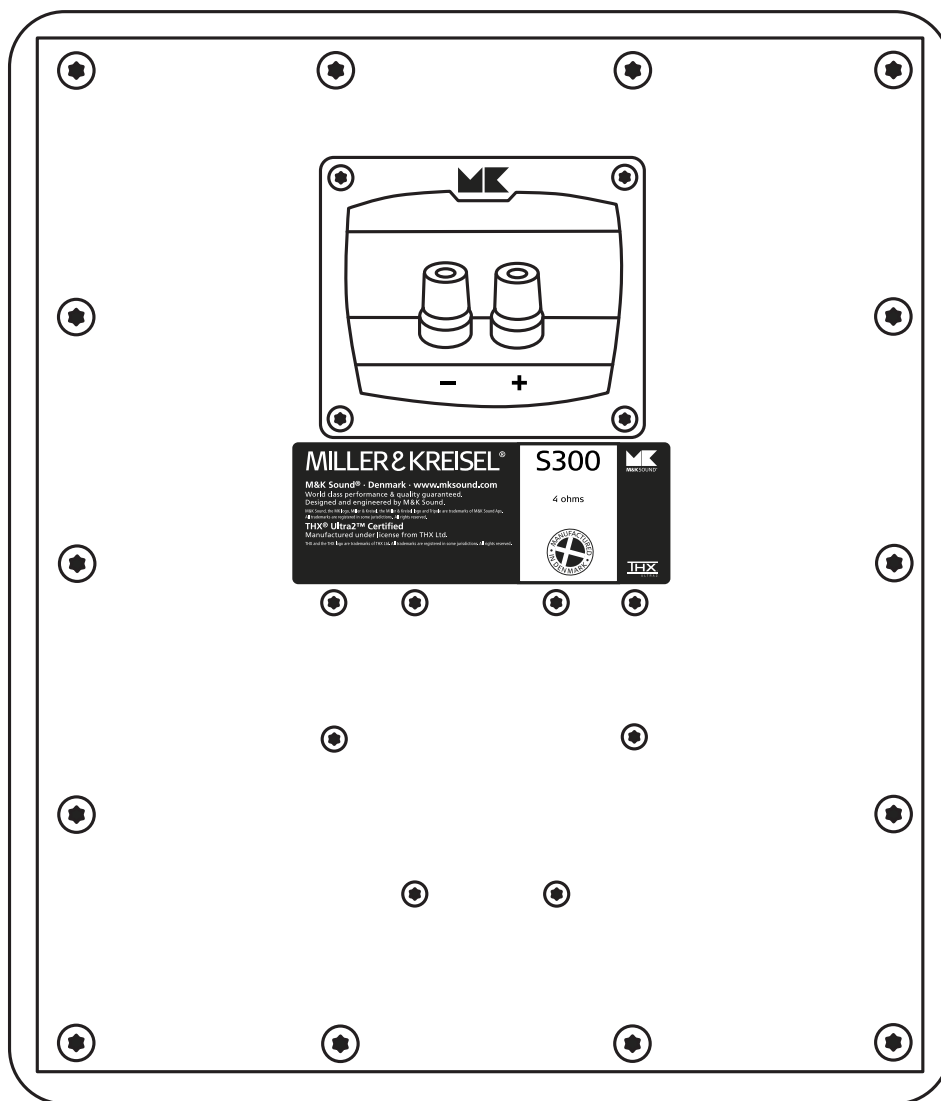

M&KSOUND®

www.mksound.com

The Choice of Professionals®