

# theCustomSoundseries

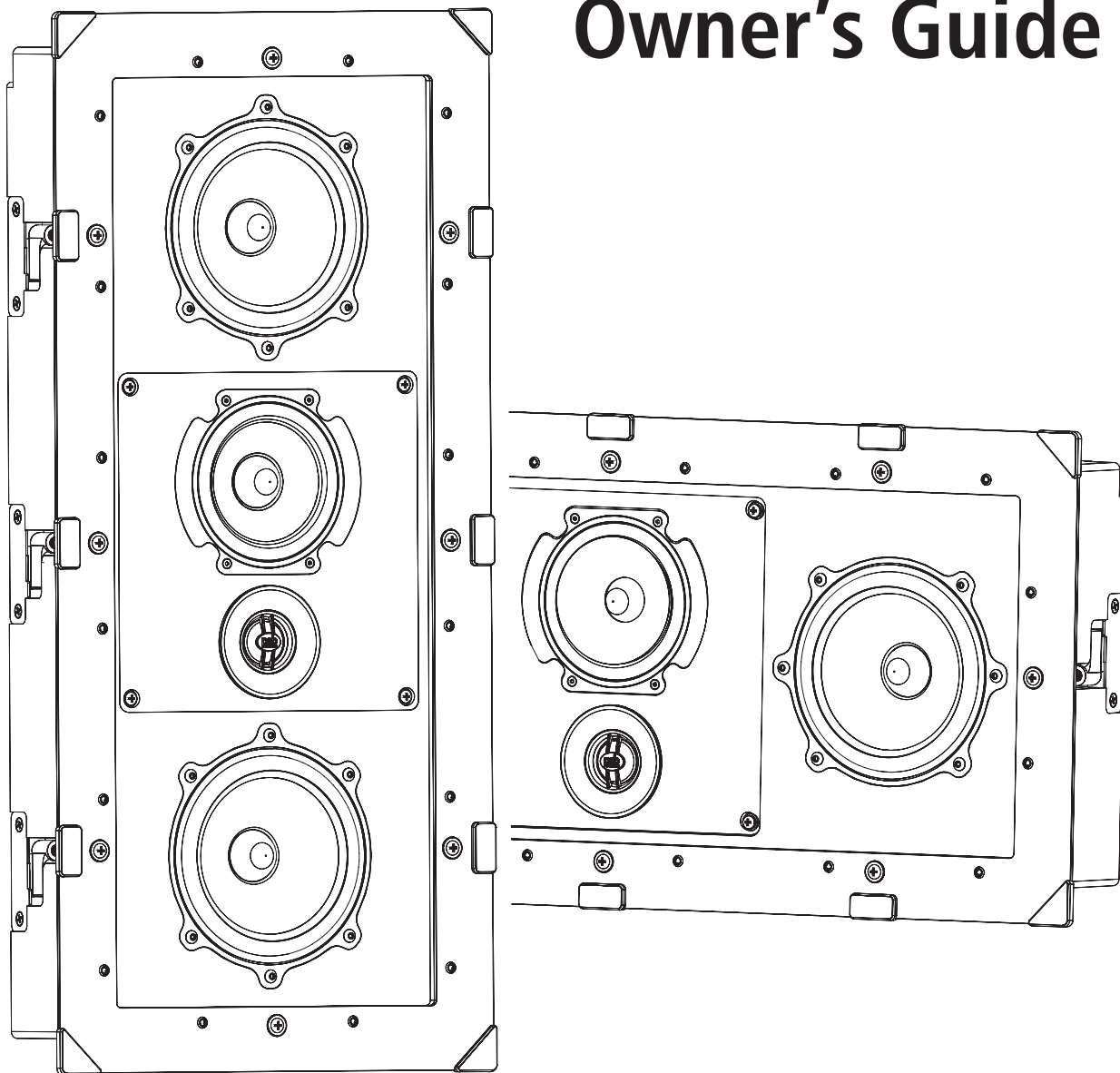

**AVAILABLE AT  
DIGITAL CINEMA**

## Owner's Guide



Thank you for purchasing PSB Speakers CustomSound In-Wall/In-Ceiling Speaker(s), a high performance architectural speaker for superior stereo and home theatre sound in residential and commercial applications. Its slim and discrete profile will disappear in the room thanks to its small dimensions, low profile perforated grille and 'frameless' design, making the speaker easy to install and conceal in all types of rooms.

Designed inside the anechoic chamber at Canada's National Research Council, this CustomSound In-Wall/In-Ceiling Speaker is engineered with PSB's unparallel driver technology from their award-winning series of In-Room loudspeakers. The new PSB CustomSound models employ clay-filled polypropylene woofer cones, titanium ferro-fluid cooled tweeter domes and carefully designed phase plugs to turn ordinary rooms and commercial spaces into live performances.

By supplying this owner's guide, we hope you will read through this booklet to help assure that you are getting the most out of your PSB product, and your music.

## UNPACKING...

The packing materials are designed to protect the speaker from damage during transport, however if visible or concealed damage is to occur in handling, it should be reported at once to your authorized PSB dealer, or to the shipping company that delivered your loudspeaker. We highly recommend retaining all packaging, as it may be needed to transport the speakers in the future.

## Required Tools

The following tools will be needed for typical installations: tape measure, pencil, level, utility knife, wallboard saw (and extra blades), screwdriver, drill, drill bits, fish tape or probe wire, and some sort of trouble light and/or flashlight.

In addition to the supplies and material listed, paint and extra fine sandpaper may be necessary if you wish to change the colour of the grille from the standard white finish.

Also, speaker wire of the appropriate length and size will be necessary to connect speakers to amplifiers and/or receivers in the commercial or home system.

## Selecting Speaker Cable

If speaker cable is not yet installed, follow these guidelines for the correct speaker cable. If cables are installed, check to ensure each cable and length of run meets these standards:

| Gauge                        | Maximum Length |
|------------------------------|----------------|
| 16 AWG (1.3mm <sup>2</sup> ) | 30 ft (9 m)    |
| 14 AWG (2.1mm <sup>2</sup> ) | 50 ft (15 m)   |
| 12 AWG (3.3mm <sup>2</sup> ) | 90 ft (27 m)   |

## Painting

Construction dust or paint on the speaker drivers will negatively affect their performance and, if significant, will void their warranty.

The grille is constructed of painted steel and can be painted following standard painting practices and techniques. Prior to painting, be sure to remove the protective scrim from the grille to avoid damaging the material. Make sure to apply at least two to three coats of paint, thinned slightly with a paint conditioner, to produce an even surface and avoid blocking grille perforations while increasing paint coverage of the sides of the holes. Spraying will yield best results.

Let a painted grille dry thoroughly in a well-ventilated area before carefully reapplying the grille scrim with reusable adhesive and installing it on the speaker.

## POSITIONING...

### Layout

CustomSound In-Wall/In-Ceiling speakers are designed to be mounted in walls or ceilings. In part to their wide dispersion characteristics and other aspects of their superb sonic performance, mounting position in your room is very flexible. Based on different requirements and the wide variety of room shapes and sizes, we highly recommend consulting your local PSB authorized dealer, or contacting a local CEDIA certified custom install specialist nearest you.

### Speaker Locations

Before installation, it is strongly suggested to consider and plan the desired, intended and probable location of listeners in relation to speaker locations. Ideally, listeners should have a clear line-of-sight.

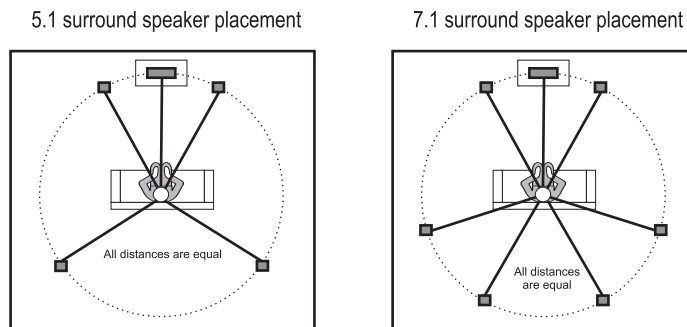

### Preparing Ceiling and Wall

Please be sure to read and understand all of the safety and preparation information on these pages to be certain installation is done accordingly.

If you are unsure about completing this process, we highly suggest consulting your local PSB authorized dealer, or contacting a local CEDIA certified custom install specialist nearest you.

**WARNING:** Ensure each spot chosen is safe for cutting. Do not cut through mounting surfaces that could have hazards such as electrical wiring, conduits, plumbing or asbestos insulation concealed behind them.

If there is some type of moveable insulation in the selected ceiling, please proceed after reviewing these tips:

- I. Wear protection for your hands, mouth, nose and eyes before handling insulation that contains fibreglass.
- II. Beware of hidden nails when reaching into the ceiling to remove insulation.
- III. Cut or push the insulation away before inserting the speaker.
- IV. Be sure to keep a 4-6 in. (10-15 cm) area around the speaker hole free from any types of insulation to maximize acoustic performance.

**Using the Cut Out Template**

- I. Centre the template in the location where the centre of the speaker grille will be located.
- II. Position the template in place on the mounting surface (e.g. use painter's tape).
- III. Trace along the cutting line of the template with a pencil.

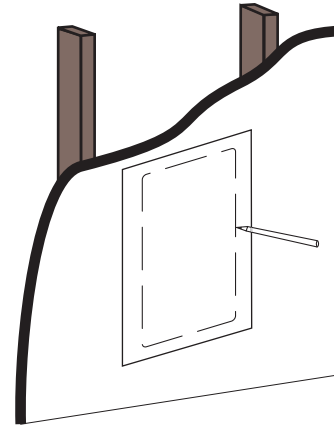

**INSTALLING...**

It is highly suggested to use eye protection and be sure to observe all safety precautions before using appropriate installation tools.

**New Construction**

- I. Using the appropriate in-wall/in-ceiling installation bracket, locate the locking tabs and connect both halves of the bracket together until secure.
- II. Take the four metal stud wings and lock them into place in the proper direction of the mounting studs.
- III. Using the assembled bracket, place it in the desired location of the speaker with the outlined edge facing outwards from the wall, and using the appropriate hardware, secure each metal stud wing to the applicable mounting studs.
- IV. Before installing wall or ceiling panelling such as drywall, map each bracket location for easier installation of the speaker once wall or ceiling panelling has been installed.
- V. For further install instructions, please follow the instructions listed in the "Existing Construction" section and all "New Construction" instructions listed within the section.

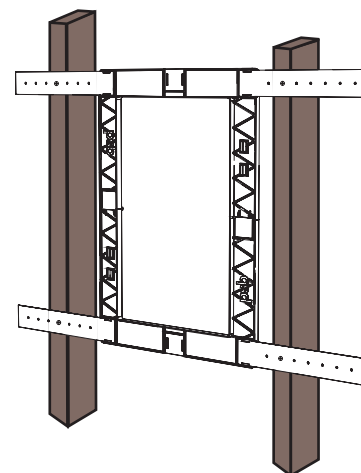
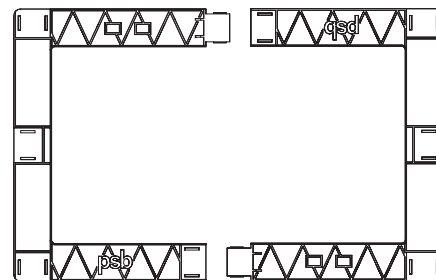

## Existing Construction

- I. Choose the appropriate drill bit to drill a hole that is large enough for the blade of your cutting tool.
- II. Drill a hole inside the area drawn with the template.
- III. Choose a spot near the centre or closer to the outside edge of the drawn area, based on the location that will be easier to begin cutting with the saw or cutting tool.

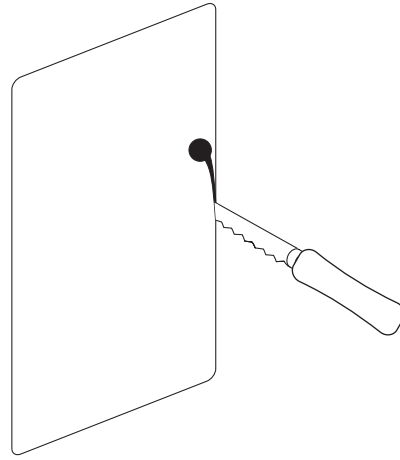

**NOTE:** Before cutting the speaker opening, be sure to cut carefully to make the opening as symmetrical as possible. However, with the speaker in place, it will overlap some of the cutting edge, which will mask minor cutting inaccuracies.

- IV. While holding the cutting blade perpendicular to the mounting surface, keep the blade as straight as possible while the opening is cut, as it will ensure the blade follows the outline.
- V. For ceiling installations, insert the tip of the saw or cutting tool into the pilot hole and cut seventy-five percent around the cutting line.
- VI. Place one hand under the surface cut out to support it and continue to complete cutting the opening.
- VII. Remove the cut out section.
- VIII. Make sure all material and debris is cleared from the hole, as such material can interfere with a proper seal between the speaker and the mounting surface.

## Preparing Speaker Cable Wires

A speaker cable consists of two insulated wires. The insulation around one wire is marked (stripped, collared, or ribbed) to identify it as positive, while the other wire is negative.

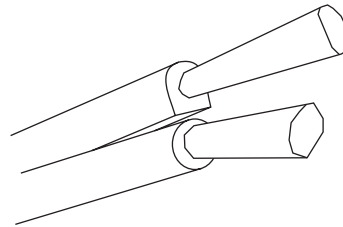

Using the appropriate tools needed, install the speaker cable to and from the desired locations for the installation. When this speaker cable is within reach of the speaker opening:

- I. Push all insulation and debris from the inside of the speaker opening, and ensure blown insulation is at least 4 to 6 in. (10 to 15 cm) from the surrounding of the opening.
- II. Locate and pull out at least 24 in. (61 cm) of the speaker cable out from the speaker opening. Make sure to ensure enough cable to connect the wires to the speaker from a comfortable position.
- III. Strip approximately 1/2 in. (13 mm) of insulation from both wires.
- IV. Twist the bare end of each wire so loose strands will not touch across terminals.

## Connecting the Speakers

When connecting speaker cable wire, be sure to connect each wire to the proper speaker and amplifier/receiver terminal for correct polarity, positive to positive (+) and negative to negative (-), and to ensure both channels move forward and backward together (in-phase).

### Bare Wire Connection

Push the top of the binding post down to line up the two holes. Insert wire through hole, and release binding post. This connection will accept up to 8-gauge wire.

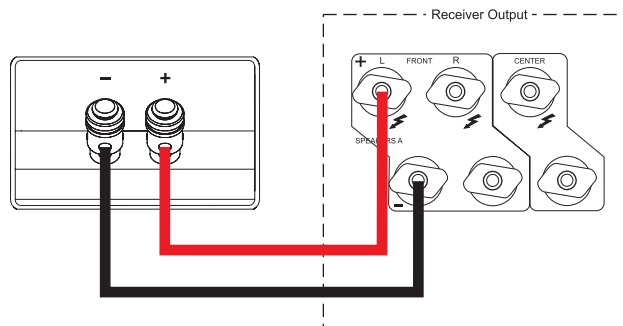
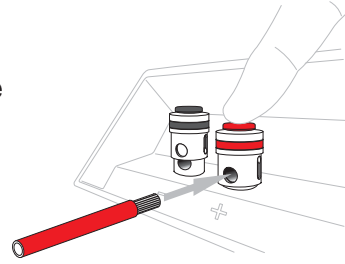

### Observe Proper Connection Polarity

- I. Slide the bare end of the positive lead into the correct, spring-loaded terminal post that is colour-coded red or marked (+).
- II. Slide the bare end of the negative lead into the correct, spring-loaded terminal post that is colour-coded black or marked (-).
- III. The wire through each terminal post should be slightly pushed over to avoid contact with wire strands from other terminal posts, or other speaker circuitry.
- IV. Ensure all wiring is properly secured before proceeding with installation. Use the speakers integrated wire management if applicable.

For more information on installing speaker cable, consult a local CEDIA certified custom install specialist or professional electrician.

## Inserting the Speaker

- I. Using two hands and holding the edge of the speaker, guide the speaker into the opening and ensure the speaker cable is not being pinched.
- II. Make sure not to press on the speaker driver cones as the speaker is guided into the opening, and be careful not to damage or remove any of the gasket material on the edge of the speaker.
- III. With the speaker in place, tighten the top-centre dogleg screw until the frame of the speaker is firmly pressed against the mounting surface. Avoid tightening the screws with too much pressure as it can cause damage to the mounting surface.
- IV. Locate the opposing dogleg screw and repeat the process, as these two tightened dogleg screws will hold the speaker temporarily in place.
- V. Repeat the same process with the other doglegs to firmly secure the speaker in place.

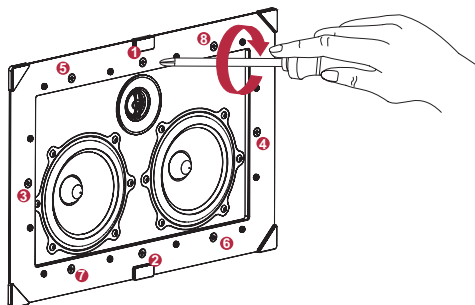

## Installing and Removing Grilles

The CustomSound In-Wall and In-Ceiling models use high-strength magnets for easy installation of the grilles to the speaker.

- I. The speaker is equipped with several magnetic strips along the edge of the speaker.
- II. Centre position the grille over the speaker until it is firmly locked in place.

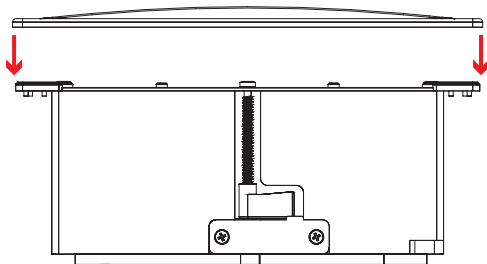

- III. If the grille will not lock into place, check to ensure the grille is properly centred on the frame, and all magnets are clear of all debris and material for proper installation.

## LISTENING...

### Testing Speakers

With the speakers now installed, ensure the speakers function properly before finalizing the installation.

- I. Before turning on the receiver/amplifier, make sure there is no unused speaker cable connected to either component, as attached cable that is free at one end can cause a short and damage your equipment.
- II. Turn on the receiver/amplifier and play familiar material to try and recognize differences or irregularities in the sound of the speaker.
- III. Ensure reproduced sounds are clear and free of distortion.

For receiver and amplifier setup, please refer to your manufacturer's manual for more information on surround modes, room EQ, and other speaker calibration settings.

## PROTECTING YOUR INVESTMENT

For long lasting enjoyment of your PSB speakers, you should respect their limits and avoid excessive volume levels for music or movie playback. Excessive volume levels can damage all types of speakers.

If your speakers are pushed to excessive volume levels, they could be driven into “clipping”, which could result in severe and/or permanent damage. If listening to your speakers at loud levels, listen carefully for any signs of harsh, distorted midrange and diminishing resolution – if detected, turn the volume down immediately.

**NEVER TEST PEAK LISTENING LEVELS OF YOUR SPEAKERS BY TURNING THE VOLUME UP ALL THE WAY!**

## CARING AND CLEANING...

It is essential to maintain and clean your speakers periodically. However, excessive cleaning may cause damage and jeopardize the longevity of the product. When not in use, avoid storing in extreme hot or cold temperatures and humidity, and avoid exposure to liquids.

### I. Grille Care

After removing the grille, vacuum the front of the speaker on a low setting, or lightly wipe the surface and perforated holes with a damp cloth to remove residue or dust from the grille. If deeper cleaning is required, use a non-hazardous cleaning product and wipe the surface. Allow the grille to dry thoroughly before carefully reattaching it to the speaker.

### II. Driver Care

During light cleaning, avoid touching speaker cones as it could cause permanent damage. If deeper cleaning is required, we suggest using a lint brush to clean the speaker cones and rubber surrounds. Never touch the metal tweeter domes.



## TROUBLESHOOTING...

### *Issue: Audible Distortion*

- I. If a speaker begins to sound distorted or fatigued, ensure all wires are in good condition, are firmly connected, and are not touching across terminals. Checking both the speaker and receiver/amplifier ends of the cable.
- II. Also, check connections from the source of music to the receiver/amplifier.
- III. Try connecting the affected speaker to a different amplifier channel to ensure that the speaker still is showing a problem. If the issue is still happening with the speaker, please contact customer support.



### *Issue: Low or No Volume Output*

- I. If there is low or no volume output, check that the receiver/amplifier is powered on, and all receiver/amplifier settings are correct.
- II. If the receiver/amplifier is indeed powered on, check and ensure that the cable connections to the receiver/amplifier are in good condition, are firmly connected, and are not touching across terminals.
- III. If other stereo speakers are connected to a second set of audio outputs on the amplifier/receiver, make sure to select the proper A or B speaker setting to match A or B outputs connected to the speakers.

If you require service, please visit your local authorized PSB service centre, or our PSB Speakers website and open a support ticket in the PSB Lounge (<http://www.psbSpeakers.com/lounge>).

If you have moved since your purchase, the nearest authorized PSB dealer will be able to assist you. If the problem is not resolved, please contact us directly and provide the model name, serial number, date of purchase, dealer name, and a full detailed description of the issue.

## Environmental Protection

At the end of its useful life, this product must not be disposed of with regular household waste but must be returned to a collection point for the recycling of electrical and electronic equipment. The symbol on the product, owner's guide and packaging, point this out.  

The materials can be reused in accordance with their markings. Through re-use, recycling of raw materials, or other forms of recycling of old products, you are making an important contribution to the protection of our environment.

Your local administrative office can advise you of the responsible waste disposal point.

We appreciate your purchase of our product, and thank you for taking the time to read this owner's guide. We hope you enjoy the exceptional satisfaction that PSB Speakers have to offer, and wish you many years of enjoyable listening.

**Real Sound for Real People.**