

PROFICIENT

Protege™

OWNER'S MANUAL



AVAILABLE AT
DIGITAL CINEMA



IWS85

Dual 8" Passive Inwall Sub

INSTALLATION CONSIDERATIONS

Proficient's IWS85 Dual 8" Inwall Subwoofer is designed to maximize the listening experience in a home theater or distributed audio system. Reading this manual will help you understand the importance of placement and crossover calibration, that the optimal balance of volume, frequency response and dispersion can be achieved.

Placing the IWS85 within 3 feet of a corner in the room will result in increased bass output at frequencies that may be desirable for home theater use. Placement beyond that point will result in smoother, more even bass performance, which is more suitable for music. Ultimately, the best placement of the IWS85 subwoofer is one that allows it to produce a neutral, uncolored sound.

The IWS85 has 200 watts power handling, with a frequency response of 30Hz to 120Hz. We recommend using the IWS85 with the Proficient M3 180 watt high-current mono amp with built-in crossover network.

It's important that a quality amplifier-crossover combination be used for precise detail and a smooth transition from the low frequencies of the other speakers down into the sub-bass range. As a Proficient installer, you'll be able to preset the crossover for just the right pass point.

When using the IWS85 with an A/V receiver with an LFE output that connects to the M3 or equivalent amplifier, follow the receiver manufacturer's instructions for crossover adjustment. The size of the woofers in the system's front left and right speakers will dictate the choice of the best crossover point in the receiver. The larger the woofers, the lower the adjustment. When making the adjustment, it's best to listen either to music you're familiar with or the test tones from the receiver. However, in some receivers the selection of certain surround modes automatically switches the crossover to a default point.

INSTALLATION

Please refer to *Diagram 1* for a quick installation overview, which will be described below:

1. CUTTING THE DRYWALL

Find the studs in the wall using a good stud finder. Locate the exact center between the studs by drilling a small hole as close to center as can be determined. Using a stiff wire (a coat hanger works well) bent to 90° feel for both studs through the hole. By turning the wire around you should be able to determine the middle location between the studs.

Once the center has been determined, use the cut-out template supplied with the IWS85 to mark and cut out the hole in the drywall.

If the area in the wall is not already insulated, add an adequate amount of insulation material to loosely cover the back of the sub. If the insulation material used is faced with foil or paper, position the foil or paper away from the subwoofer.



CAUTION: Speaker components can get hot while playing music at moderate to high volume levels. There should be nothing at all touching the speaker. Material in proximity to the back of the speaker must have at a minimum 1" or 26mm clearance for non-flammable materials and more for flammable materials like plastic vapor barriers.

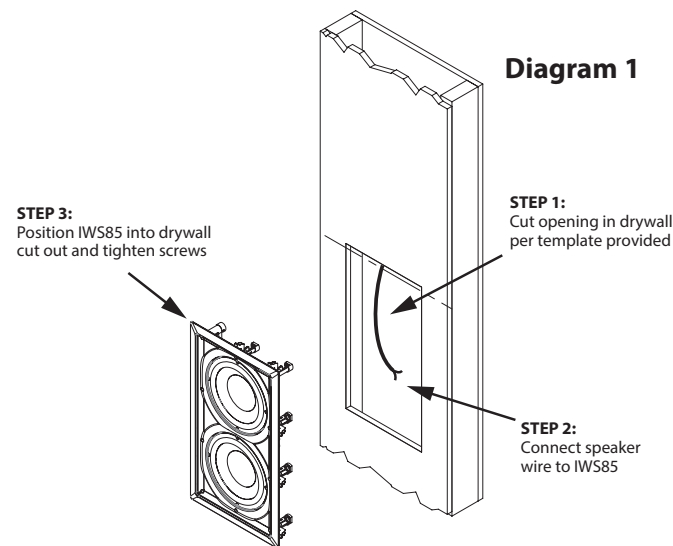

2. WIRING

Connect the speaker wire to the IWS85, be sure to connect the positive wire to the terminal marked (+) and the negative wire to the terminal marked (-). **Note:** Make sure the binding posts (wire connectors) are tightened firmly or they may rattle. The other end of the wire should be connected in the same manner to your amplifier's inputs marked "SUBWOOFER OUT". Make sure that the amplifier is unplugged when connecting any wires or cables to it.

3. MOUNTING THE IWS85

The IWS85 has been specifically designed to mount to the drywall. Place the sub into the drywall cut-out and position it. As you tighten the screws, the mounting feet turn and clamp the sub to the drywall. See *Diagram 2*. **CAUTION: Be careful not to overtighten the screws or the baffle will warp, and the mounting feet may break off.**

Once the sub is in place, you can gently reattach the grille onto the baffle. Due to the nature of the system, the grille is designed to attach very tightly.

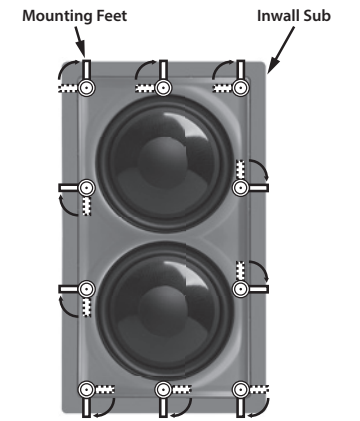

Diagram 2

PAINTING THE GRILLE

We recommend painting your grille prior to installation. If you decide to paint it in the future, it's best to remove the grille by simply detaching it from the speaker. Do not paint the grille while it's installed on the speaker.

Before painting, be sure to remove the cloth material from beneath the grille. Once painted, place the cloth back to its position beneath the grille. When painting, be careful not to clog the holes of the grille. The sound of the speaker will be dramatically reduced if the perforations in the grille are covered in paint.

Proficient recommends only light spray painting using five parts thinning agent to one part paint.

TROUBLESHOOTING

The IWS85 Dual 8" Inwall Subwoofer is designed to function trouble-free. Most problems occur because of operating errors. If you have a problem, please check the troubleshooting list first. If the problem persists, contact Tech Support at 877.888.9004 or e-mail us at techsupport@proficientaudio.com.

The Problem	Possible Causes and Solutions
No sound is heard.	Audio cable to the amplifier is not connected properly or the cable is bad. Use another cable that you know is good. Check all speaker wire connections and plugs. Volume Limit on amp may be set too low.
A hum or buzzing sound is heard.	The sound may be caused by a ground loop in the system. Try to eliminate this by reversing the AC plugs of other components in the system. Try plugging the amplifier into another outlet. Other causes may include faulty cables.

SUBWOOFER SPECIFICATIONS

	IWS85
Speaker Type:	Passive Inwall Subwoofer
Woofers:	Dual 8" Long Excursion Graphite Woofers
Power Handling:	200 Watts
Frequency Response:	30Hz - 120Hz
Sensitivity:	95dB 1W/1m
Grille:	Thin-Bezel held by Neo Magnets
Dimensions (H x W x D):	20 ⁵ / ₁₆ " x 11 ⁵ / ₁₆ " x 3 ³ / ₄ "
Wall Cut Out (H x W):	19 ¹ / ₈ " x 10 ⁵ / ₈ "

Features and specifications are subject to change without notice.

LIMITED TEN-YEAR WARRANTY

Proficient Audio Systems ("Proficient") warrants to the original retail purchaser only ("you") that this product will be free from defects in materials and workmanship for a period of ten years (the "Warranty Period"), subject to the limitations and exclusions set out in this Limited Warranty. This warranty is not transferable to subsequent owners of the product. If you discover a defect in material or workmanship within the Warranty Period, you can obtain warranty service by contacting Proficient during the Warranty Period at 800.472.5555 or techsupport@proficientaudio.com or by sending the product to Core Brands at 12471 E. Riverside Drive, Eastvale, CA 91752 or to the dealer from whom you purchased the product. Defective products must be shipped, prepaid and insured, together with proof of purchase. Warranty service requests made without proof of date of purchase will be denied. Freight collect shipments will be refused. It is preferable to ship this product in the original shipping container to lessen the chance of transit damage. In any case, the risk of loss or damage in transit is to be borne by the purchaser.

If, upon examination by Proficient or its authorized dealer, it is determined that the unit is in fact defective, Proficient will, at its option:

- Repair or replace the product at no additional charge; or
- If the model is no longer available and can not be repaired effectively, replace the unit with a current model of equal or greater value. In some cases where a new model is substituted, a modification to the mounting surface may be required. If mounting surface modification is required, Proficient assumes no responsibility or liability for such modification.

Proficient will bear the cost of returning the repaired or replaced product to you, freight prepaid. All replaced parts and product become the property of Proficient Audio Systems. The foregoing is your sole and exclusive remedy for breach of warranty. If the product is not found to be defective, Proficient will contact you to arrange for return of the product to you, at your expense.

EXCLUSIONS:

- This Warranty does not include service or parts to repair damage caused by accident, disaster, misuse, abuse, negligence, inadequate packing or shipping procedures, commercial use, voltage inputs in excess of the rated maximum of the unit, or service, repair or modification of the product by unauthorized dealers. This Warranty also excludes normal cosmetic deterioration caused by environmental conditions.
- This Warranty will be void if:
 - the Serial Number on the product has been removed, tampered with or defaced.
 - the product was not purchased from an authorized dealer.

THE FOREGOING WARRANTIES ARE EXCLUSIVE AND IN LIEU OF ALL OTHER EXPRESSED AND IMPLIED WARRANTIES. PROFICIENT EXPRESSLY DISCLAIMS ALL SUCH OTHER WARRANTIES, INCLUDING BUT NOT LIMITED TO IMPLIED WARRANTIES OF MERCHANTABILITY, FITNESS FOR A PARTICULAR PURPOSE AND NON-INFRINGEMENT.

In no event will Proficient be liable for any incidental or consequential damages arising out of the use or inability to use the product, even if Proficient has been advised of the possibility of such damages, or for any claim by any other party. Notwithstanding the above, if you qualify as a "consumer" under the Magnuson-Moss Warranty Act, then you may be entitled to any implied warranties allowed by law for the Warranty Period. Further, some states do not allow limitations on how long an implied Limited Warranty lasts or allow the exclusion or limitation of consequential damages, so such limitations may not apply to you.

ATTENTION TO OUR VALUED CONSUMERS:

To insure that consumers obtain quality pre-sale and after-sale support and service, Proficient products are sold exclusively through authorized dealers. **Proficient products are not sold online** by Proficient or its authorized dealers, and this warranty is **VOID** if the products have been purchased from any internet reseller. To determine if your Proficient reseller is authorized, please call Proficient at 800.472.5555 or go to proficientaudio.com.

For technical inquires, please call 800.472.5555 or e-mail us at techsupport@proficientaudio.com. We are available to assist you every weekday, except holidays, between the hours of 7:00 a.m. and 5:00 p.m. PST.

PROFICIENT

1800 South McDowell Blvd • Petaluma, CA 94954
800.472.5555 • Fax 707.283.5901 • proficientaudio.com

©2013 Core Brands, LLC. All Rights Reserved.
Proficient® is a registered trademark of Core Brands, LLC, a subsidiary of Nortek, Inc.



9901323 (Rev B)