

DIGITAL
CINEMA

AVAILABLE AT
DIGITAL CINEMA

Sunfire™

XT
SERIES

*Cinema Ribbon
In-Wall Loudspeakers
CRW-2 and CRW-2C*

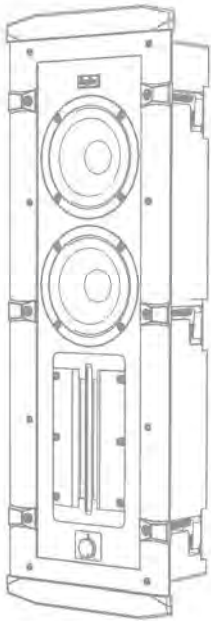

CRW-2

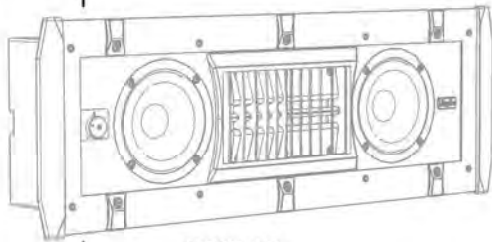

CRW-2C

*Installation Instructions and
User's Manual*

Important Safety Instructions

1. Read Instructions.
2. Keep these Instructions.
3. Heed all Warnings.
4. Follow all Instructions.
5. Do not use this apparatus near water.
6. Clean only with a dry cloth.
7. Do not install near any heat sources such as radiators, heat registers, stoves, or other apparatus (including amplifiers) that produce heat.
8. Refer all servicing to qualified service personnel. Servicing is required when the apparatus has been damaged in any way, such as a connector is damaged, liquid has been spilled or objects have fallen into the apparatus, the apparatus has been exposed to rain or moisture, does not operate normally, or has been dropped.
9. Object and Liquid Entry — Care should be taken so that objects do not fall into and liquids are not spilled into the inside of the apparatus.



WARNING: THIS LOUDSPEAKER IS CAPABLE OF PRODUCING VERY HIGH SOUND PRESSURE LEVELS. YOU MUST TAKE EVERY PRECAUTION TO PROTECT YOUR HEARING FROM PERMANENT DAMAGE.



Dimensions

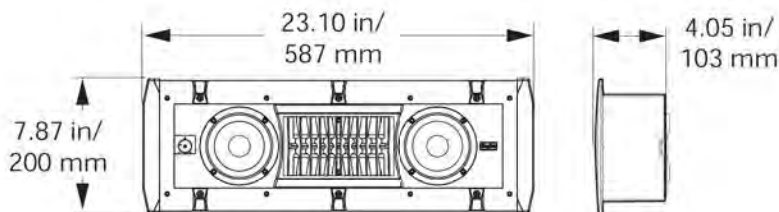

CRW-2 and CRW-2C (same dimensions for each)

Wall cutout required:
6.4" H x 20.8" W
(163 x 528 mm)



Contents

Safety Instructions.....	2
Dimensions	2
Introduction	4
Features	6
Location	8
Using a subwoofer	11
Break-in period	12
Installation	13
Wiring	14
Specifications	17
Troubleshooting	18
Limited Warranty	19
Service Assistance	19

For more information on this and other Sunfire products, please visit our website:

www.sunfire.com

Introduction

Thank you for purchasing a Sunfire XT-Series Cinema Ribbon in-wall loudspeaker. We hope you enjoy it and the music it makes as much as we have enjoyed creating it for you.

As an exclusive XT-Series product, this loudspeaker follows a great heritage of both world-class ribbon loudspeaker designs and industry-leading subwoofer technologies.

The CRW-2 and CRW-2C loudspeakers are designed as a perfect match to our True Subwoofer and SubRosa series, resulting in the ultimate home theater experience... the kind of heart-felt experience that could only come from Sunfire.



The loudspeakers should only be installed by qualified and experienced professional installers.

Unpacking

Your Sunfire Cinema Ribbon CRW loudspeaker should reach you in perfect condition. If you do notice any shipping damage, please contact Sunfire immediately.

Gently lift out the loudspeaker and all the packing material. It is important to save all the packing materials and the box in case your loudspeaker ever needs to be moved or shipped for repair.

Make sure that you keep your sales receipt. It is the only way to establish the duration of your Limited Warranty and it may come in useful for insurance purposes.

Features

- CRW-2 loudspeaker for front, surround, and surround back applications
- CRW-2C loudspeaker for center channel applications
- 2 way, high-pressure design
- Magnetically shielded
- Waveguide-loaded Neodymium ribbon
- Two 4.5-inch High Back-emf drivers
- 115 dB maximum output
- 400 watts maximum power
- Stylish black anodized aluminum frame with end caps
- Magnetic grille
- Ribbon level control
- One pair of gold-plated spring terminals
- Optional pre-construction bracket

Care

If your loudspeaker needs servicing, please read the Troubleshooting section on page 18. If a problem persists, please contact your nearest authorized Sunfire Dealer.

Please take a moment to fill out and mail the Sunfire Customer Response card. Also read the serial number located on the rear label and record it here:

Serial Number:

Purchased from:

Date:

Overview

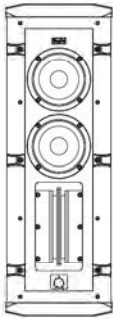

CRW-2 loudspeaker

CRW-2C center loudspeaker

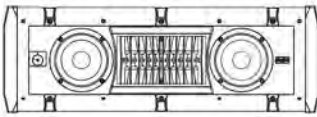

The Cinema Ribbon CRW-2 and the CRW-2C are high performance loudspeakers that are specifically designed to work with your flat panel display. Sharing technology with the rest of the Cinema Ribbon line, years of research and decades of experience have gone into these amazing loudspeakers.

The ribbon - a legacy refined

The ribbon in this loudspeaker is a remarkable piece of engineering, because it has the output capability, purity, and low distortion of a large 6-foot-tall ribbon - in fact, it is derived from Bob Carver's award-winning Amazing Loudspeaker from the late 1970s! The sound from the CRW-2 ribbon is deliberately focused in the forward direction, with very little sound going up or down - reducing reflections off the ceiling and floor, that disturb our sense of space and imaging. The CRW-2C features an integrated "acoustic lens," that disperses the signal for center channel applications.

The woofers - a legacy refined

Sunfire created the category of small-box, high-power subwoofers more than

a decade ago with the original True Subwoofer. This design relies on high-pressure, "High Back-emf" technology that provides very high bass output from a very small box. When migrating this subwoofer technology to the midrange and high frequencies on the Cinema Ribbon CRW loudspeakers, you get the same advantages: high output, small size, high efficiency, and years of trouble-free operation.

Conclusion

The Cinema Ribbon CRW loudspeakers are a no-compromise answer to the age-old question of Form vs. Function. Why not get both? Combine these speakers with the SubRosa In-wall subwoofer for the ultimate in hidden high performance.

Installation overview

A template is supplied to help mark the sheetrock for cutting. A paint shield is also supplied to aid in painting the loudspeakers.

An optional pre-construction bracket is available that will help you install the loudspeakers in rooms that are under construction. Please contact Sunfire to order this bracket. (It comes with its own installation guide.)

The CRW-2 may be mounted vertically between wall studs, either side of your big screen display.

The CRW-2C may be mounted horizontally, above or below your display. For existing walls, the horizontal mounting will involve cutting a vertical stud and some extra framing.

The CRW-2C may also be used vertically as left and right loudspeakers, in which case, the acoustic lens can be removed.

A system of six screw clamps secure the loudspeaker firmly in place in the sheetrock, once the opening has been cut.

Features

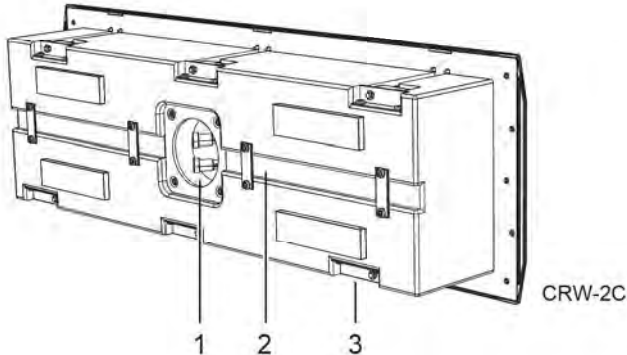

1. Binding Posts

Each loudspeaker has one pair of gold-plated spring-loaded binding posts.

Always use high quality connections and speaker wires, and make sure there are no loose fittings or stray wire strands. The spring connections accept bare wire or pins.

Connect the positive speaker-level output of your power amplifier or receiver to a positive (red) input of the loudspeaker. Connect the negative speaker-level output of your power amplifier or receiver to a negative (black) input of the loudspeaker.

Make sure that the positive and negative connections do not touch, or this may damage your power amplifier.

2. Speaker Wire Channel

To ease installation, the speaker wiring can be passed through these channels to the binding posts.

3. Clamps

Once the loudspeaker is pressed into an opening in the sheetrock, screws on the front panel are turned to pull the clamps out and down to press against the sheetrock, and secure the loudspeaker in place.

4. End Caps

These decorative end caps can be painted to match your room decor. A paint shield (12) is supplied to cover the drivers during painting.

5. Ribbon Adjustment

This allows you to adjust the level of the ribbon section relative to the other drivers. The range of adjustment is ± 3 dB, and the default setting is in the middle (0 dB). Perform a listening test and adjust as desired.

6. Woofers

The CRW-2C and CRW-2 use two identical custom drivers.

CRW-2C

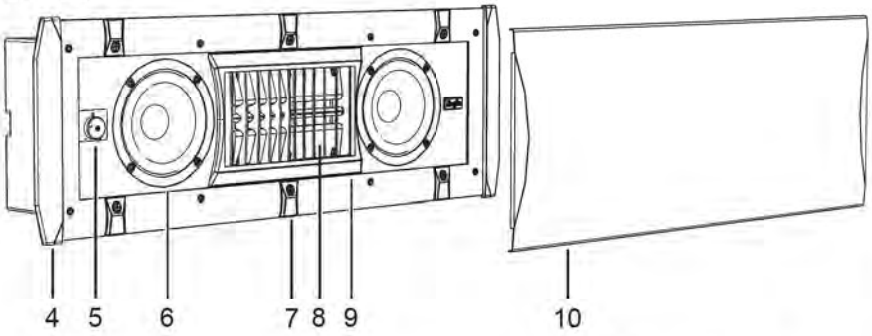

7. Clamp Screws

These screws are used to clamp the loudspeaker in place, once it has been pressed into the sheetrock opening of your wall.

8. Ribbon

The CRW-2C and CRW-2 use the same ribbon driver.

9. Lens (CRW-2C only)

The CRW-2C uses an acoustic lens over the ribbon to optimize the performance as a center loudspeaker.

10. Grille

The grille is attached to the main body with magnets. To remove the grille, gently pry it away from the corners.

11. Cutout Guide

This allows you to easily mark the required cutout onto your wall.

12. Paint Shield

This covers the drivers and frame when painting the end caps to match the walls.

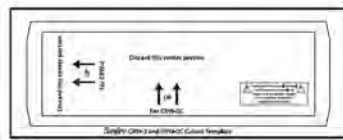
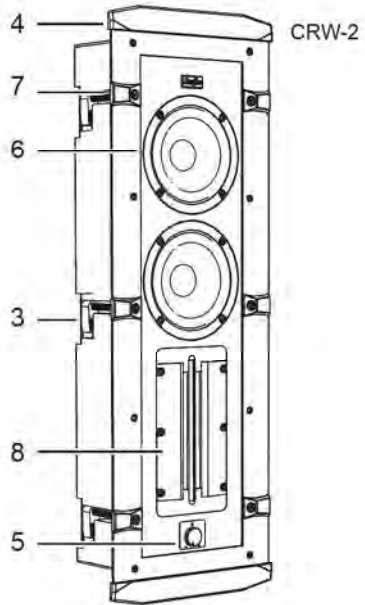

11

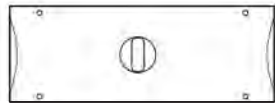

12

Loudspeaker Location

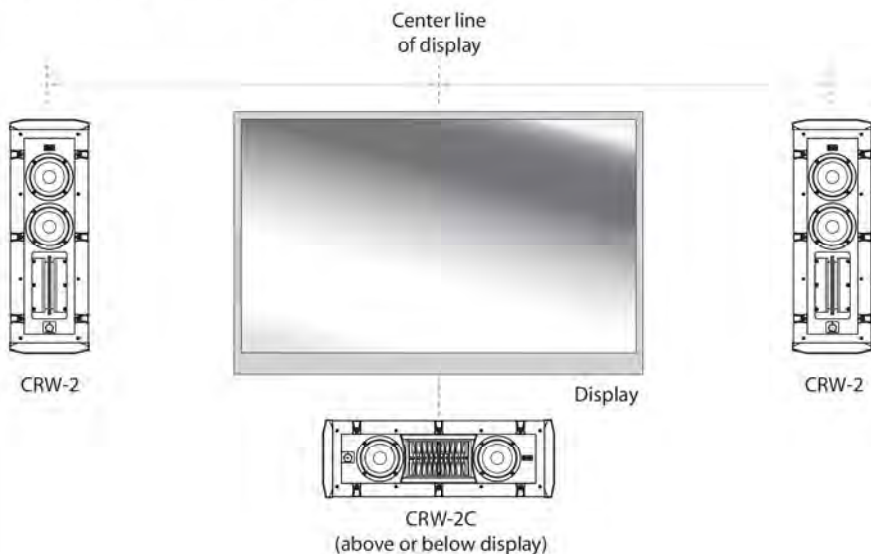

The CRW series loudspeakers are designed to be a perfect sound compliment to flat panel displays. The CRW-2C center loudspeaker can be mounted above or below the display, and the CRW-2 can be mounted at either side.

The following details show various systems incorporating the loudspeakers, with a subwoofer to handle the low frequency range.



As with all loudspeaker installation, check that the position does not interfere with the picture quality.

Ideally, all of the surround loudspeakers in a home theater system should be of the same make and model, and positioned at similar heights to produce a smooth and continuous soundfield. Sunfire Cinema Ribbon CRM-2BIP bipole loudspeakers use the same drivers and ribbons as the CRW series, making them perfect for rear channel applications. Alternatively, you could use additional CRW-2 loudspeakers.

Front Left/Right Speakers

The front left and right CRW-2 loudspeakers should be positioned so that your TV display is exactly centered between them. This will help focus your attention towards the display.

Your left loudspeaker should be set exactly the same distance and angle away from your listening position as the right loudspeaker.

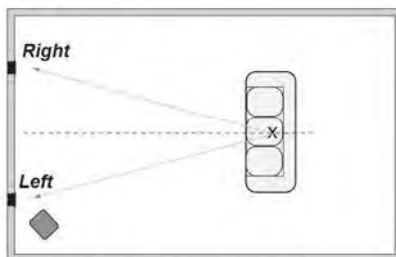

Front left and right loudspeakers

If you have a smaller TV, the loudspeakers should be no more than two feet away from the sides of the display.

If you have a Sunfire or Carver system equipped with Sonic Holography, then it is recommended that you use a tape measure to set the left and right loudspeakers to be an equal distance away from your listening position, within half an inch tolerance. (Sonic Holography is a unique process designed by Bob Carver to enhance the three-dimensional effects and realism of stereo sound.)

The Center Loudspeaker

Most movie dialog will come from the center loudspeaker, so careful positioning is an important part of a good home theater system. Your eyes and ears should focus your attention towards the center of the display.

The CRW-2C center loudspeaker can be placed either above, or directly underneath the display, as long as it is located on the centerline and not off to one side.

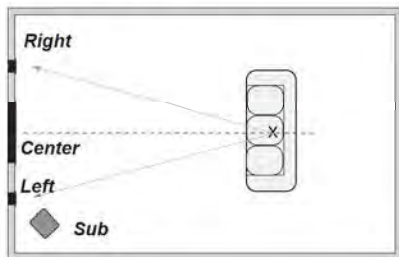

Center loudspeaker

If possible, have the center, left and right loudspeakers at the same height (within two feet). This will help give a smooth transition when sound effects move from loudspeaker to loudspeaker.

The CRM-2BIP ribbon loudspeakers may be used as surround loudspeakers, as shown in the following systems and illustrations.

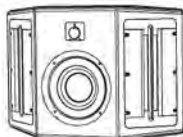

Sunfire CRM-2BIP surround loudspeaker

5.1 Configuration

Place each surround loudspeaker an equal distance away from your central listening position, and keep them at least one or two feet above ear level (with you sitting down).

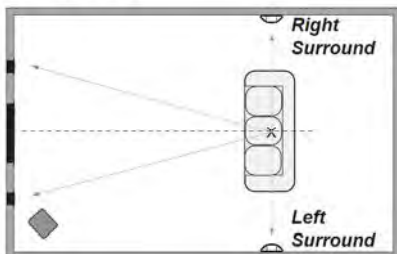

5.1 System

They can be placed either side of the listening position.

6.1 and 7.1 Configuration

Sunfire home theater processors and receivers have two extra outputs for surround back loudspeakers. These create a wonderful sense of realism in surround effects during playback of Dolby Digital EX, Dolby Pro Logic IIx, and DTS-ES.

Such systems can be configured for one or two surround back loudspeakers.

If you are connecting one surround back loudspeaker, place it directly behind your listening position, with the surround loudspeakers to the side as shown.

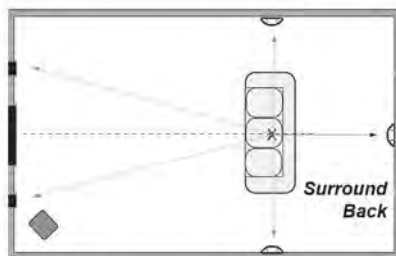

6.1 System

With two surround back loudspeakers, set them behind and between the surround loudspeakers.

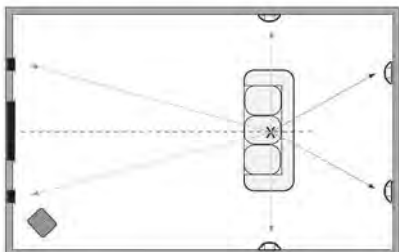

7.1 System

9.1 Configuration

Some Sunfire home theater processors and receivers have two side-axis channels that are matrixed from the left and right front channels, and they are available in stereo as well as surround modes.

For the side-axis, you could use another pair of CRW-2 loudspeakers.

Place the side-axis loudspeakers along the side walls, close to the fronts.

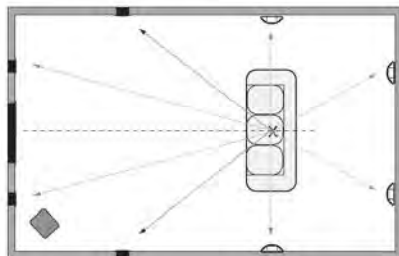

9.1 System

Subwoofer Location

The best location for a single subwoofer can be found by following these steps:

1. Place the subwoofer on your couch or favorite easy-listening chair.
2. You can then either run a calibration (noise) signal through it, or play some of your favorite music samples with heavy bass.
3. Walk around the room, standing in all the positions where you might be able to place the subwoofer. This is usually somewhere close to the corners of the room. Try locations fairly close to the front loudspeakers, and try crouching down low.
4. Find the place in the room where the bass output from the subwoofer is most even. Shut things down and install the subwoofer there.
5. This is the best position for the subwoofer. The bass will sound the best when you are sitting in your normal listening position.

Using a subwoofer



The Cinema Ribbon CRW loudspeakers are designed to be used with a subwoofer to fill in the lower frequency range. They are not designed to accept 400 watts of power at the full frequency range.

Your system should be designed so that the Cinema Ribbon CRW loudspeakers receive only the range above 80 Hz, with a subwoofer to handle the frequencies below 80 Hz.

Sunfire home theater processors and receivers have a bass management system that allows you to redirect the bass frequency range of each channel to the subwoofer. The advantages are :

- The overall bass of the system is improved, as subwoofers, such as Sunfire's powered True Subwoofers are specially designed for this frequency range.
- The subwoofer can simultaneously play the bass from all of the loudspeakers, in addition to it's own low frequency effects channel (LFE).
- There is no loss in perception of the position of movie or music sound effects, as the ear cannot easily locate the position of bass sound sources.
- Compact loudspeakers can be used for front, center and surrounds, as they do not have to reproduce the low frequency range. This leads to a saving in room space.
- Your amplifiers do not waste power reproducing the low frequency range.

Crossover adjustment

We recommend that you set your home theater processor's crossover to 80 Hz, and set the channels that use the Cinema Ribbon CRW loudspeakers to "small."

- Your subwoofer receives frequencies below 80 Hz, from all loudspeakers whose size is set to small, in addition to the LFE channel:

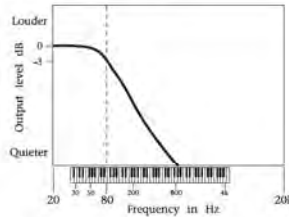

- All loudspeakers set to small, receive frequencies above 80 Hz.

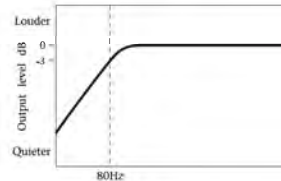

- Set your subwoofer's own crossover control (if it has one) to maximum frequency or bypassed mode. If it is set lower than the 80 Hz, there would be a hole in the mid-bass, and bass information would be missing.

The acoustic summation of the subwoofer output and the Cinema Ribbon CRW output produces a flat frequency response.

NOTE: Dolby Digital and DTS modes are designed especially for complete systems with front, center, and surround loudspeakers and subwoofers. You need all of the loudspeakers to get the best performance from your Home Theater. If

continued..

you do not have a subwoofer connected, you will be missing the 5.1 LFE (low frequency effects) information.

NOTE: If your processor or preamplifier does not have a crossover control, you might need an external active crossover to split the audio signal into a low-pass range for the subwoofer, and a high-pass range for the Cinema Ribbon CRW loudspeakers. (Sunfire subwoofers have their own crossover controls with line-level high-pass outputs that can be used to power an amplifier connected to Cinema Ribbon CRW loudspeakers.)

Break-in period

Like many high performance automobiles, the Cinema Ribbon CRW loudspeakers perform at their best after an initial break-in period. A minimum of 20 hours is recommended prior to performing critical listening, however the speakers will sound their best after a period of 300 to 400 hours. During this time, the driver suspensions and ribbon structure will relax into their operating design positions and give optimum performance.

To facilitate break-in during the initial 20 hours, it is recommended that you play material with a wide dynamic range at louder volumes – such as your favorite rock and roll album (that is if your family or neighbors can stand it).



It is important that your amplifier must supply good clean power, and not run into distortion. Amplifier distortion due to clipping, causes high-frequency output components that can damage loudspeakers. Even a 100 watt amplifier running into clipping can damage loudspeakers rated at 400 watts or more.

Installation

Read the details on page 8 to help determine the best position for your loudspeakers.

CRW-2C

The CRW-2C center loudspeaker can be fitted horizontally, either above or below the display. A pair can also be used as left/right speakers if the acoustic lenses are removed. This is done by gently prying them off at the four corners.

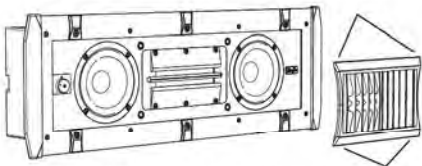

Horizontal mounting into existing construction will most likely mean cutting a vertical stud. This installation should be done by an experienced and qualified carpenter, to prevent weakening the wall structure. When the extra framing is done, the installation and wiring is the same as described as follows for the CRW-2.

CRW-2

The CRW-2 loudspeakers can be wall mounted vertically, for example, on either side of a display. We recommend that the ribbon section is positioned at a height close to ear-level, therefore you can fit the CRW-2 loudspeakers with the ribbon at the bottom if necessary.

Tools required:

- Phillips screwdriver or screw gun
- Pencil or other suitable wall marker
- Sheetrock saw
- Safety glasses
- Level
- Sturdy ladder or step ladder
- Electronic stud finder if needed
- You may need an assistant.

Preliminary steps:

- If the TV display is in place, it should be removed from the wall.
- Clear the area where you are going to work, so it will be safe. Remove any fragile objects, small children or pets, and cover anything that might be affected by dust from cutting sheetrock.
- Put on your safety glasses.

Marking and cutting the opening

1. Choose the best location for your CRW-2 loudspeakers, preferably centered between vertical wall studs. Use a stud finder to find where the studs are.



Do not position the loudspeaker closer than one inch from the cabinet sides to a stud. This allows for the clamps to swing out. Check there is no electrical wiring or plumbing behind where you are cutting.

2. Hold the cutout template onto the wall surface, and use a level to make sure it is vertical.

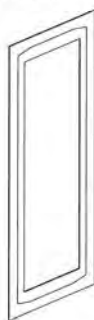

Marking the opening onto the wall using the inside of the template

3. Mark the sheetrock with a pencil around the inside of the template, and remove the template.

- Carefully cut out the sheetrock around the marked lines, and remove any debris from the hole.

Wiring

The front channels of Sunfire's Theater Grand Amplifiers each have two pairs of outputs. In a normal system, use the **voltage source**.

This example shows the speaker wiring connections for a right front speaker. On conventional amplifiers, use the standard positive and negative speaker-level outputs.

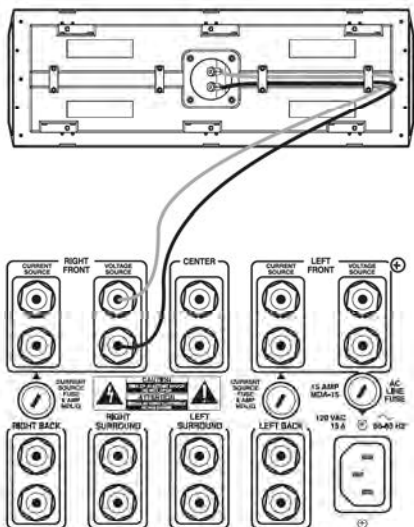

- Install the speaker wires following all local codes for electrical wiring installation. Use class 2 wiring, and 12 gauge is recommended, 16 gauge is the minimum.
- Follow common low voltage practices like avoiding high voltage electrical wiring, or crossing them perpendicularly. This will reduce the chance of picking up hum or other interference.

- Pass the wiring through the wiring channels in the back of the loudspeaker (see item 2 on page 6.)
- Do an electrical continuity test to make sure the connections are good from the amplifier-end of the speaker wire to the ends of the wires at the loudspeaker.
- Secure the wiring to the loudspeaker's spring-loaded binding posts, observing the correct polarity. Gently pull on them to make sure they are secure.

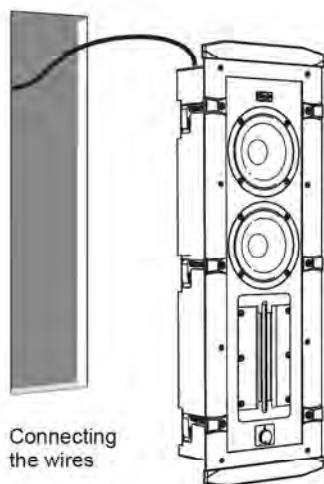
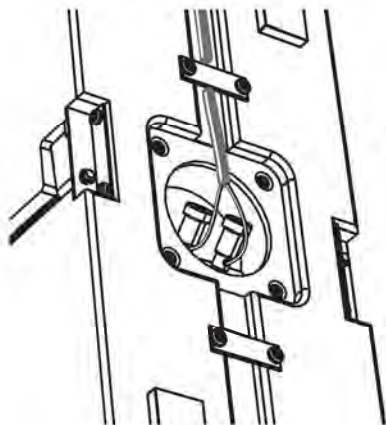

6. It is a good idea to secure the wiring from vibration as much as possible. Do not have the weight of the cables hanging on the terminals.

Fitting the loudspeaker

1. Press the loudspeaker into the sheetrock opening, and screw in the six clamp screws. As the screws turn clockwise, the clamps rotate out and press onto the back of the sheetrock to hold the loudspeaker firmly in place.

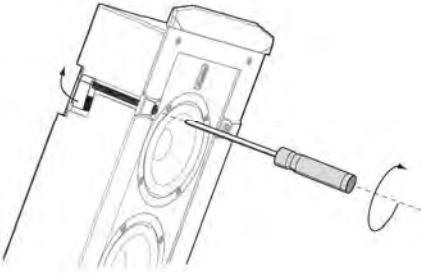

Tighten the clamps (the sheetrock is not shown for clarity)

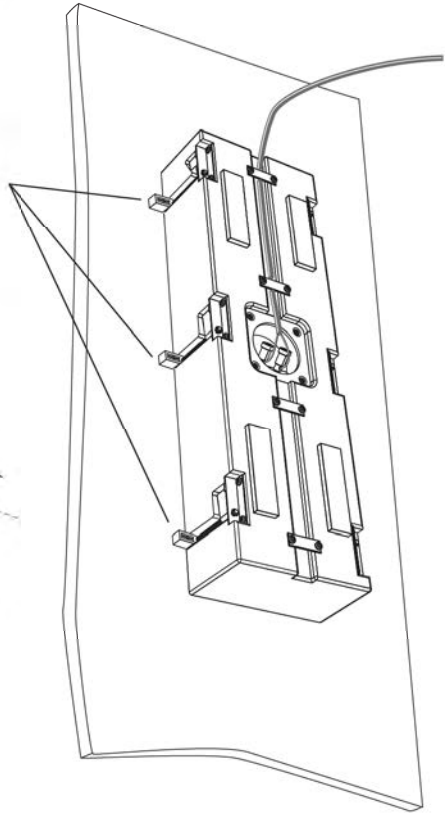

Rear view showing the clamps engaged and the wiring in place

Painting the loudspeaker

1. Press the paint shield in place to cover the woofers and ribbon during painting.
2. Remove the paint shield when the painting is done.

Final steps

1. The supplied Sunfire badge can now be pressed in place to match the orientation of your loudspeaker. The adhesive backing holds it in place



2. Add the magnetic grille to cover the woofers and ribbon.

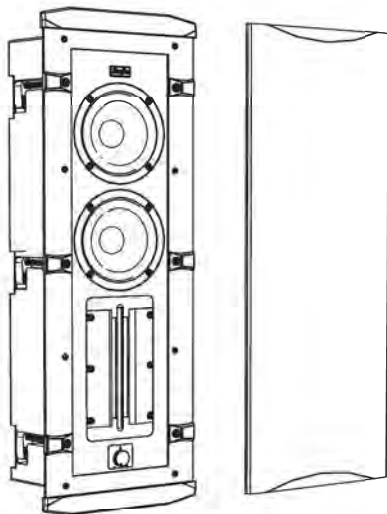

3. Enjoy your new loudspeaker. See page 12 regarding the break-in period required before the loudspeakers will sound their best.

Specifications

Design

2-way, High Pressure
Magnetically Shielded

Drive Units

HF: Waveguide loaded Neodymium
Ribbon
LF: Dual 4.5-inch High Back-emf

Frequency Response

95 Hz to 40 kHz

Crossover Frequency

1.5 kHz

Maximum Power

400 watts

Minimum Power

25 watts

Sensitivity (2.83 V/1 meter)

90 dB

Maximum Output

115 dB

Impedance

8 ohms nominal

Connections

1 pairs gold plated spring terminals

Dimensions

(Maximum dimensions, including grille)

CRW-2

Height	23.10" (587 mm)
Width	7.87" (200 mm)
Depth	4.05" (103 mm)
Cutout	20.8" x 6.4" (528 x 163 mm)
Weight	15 lb (6.8 kg)

CRW-2C

Height	7.87" (200 mm)
Width	23.10" (587 mm)
Depth	4.05" (103 mm)
Cutout	6.4" x 20.8" (163 x 528 mm)
Weight	15 lbs (6.8 kg)

© 2008 Sunfire, LLC.

All rights reserved. Sunfire, LLC reserves the right to improve its products at any time. Therefore, specifications are subject to change without notice.

Manual 913-156-00 Rev A

Troubleshooting

The Cinema Ribbon CRW loudspeakers are designed and built to provide years of trouble-free performance. Most problems that occur can usually be solved by checking your setup, or by making sure all components are fully operational.

The following information will help you deal with common problems you may experience. If a problem persists, please contact your Dealer for assistance.

Poor or no sound

- Check all the connections from the loudspeaker to the amplifier or receiver. Swap loudspeakers around, and see if the poor sound follows a particular loudspeaker.
- Check that your amplifier is not driven too hard or is clipping. Even a low-powered amp driven into clipping can cause distortion or damage your loudspeakers.
- Many processor/preamps can send test tones through all the loudspeakers in your system. Use this to adjust the volume of each channel until they are all playing at the same level. Make sure that any bass management options are set correctly, and any channels using the Cinema Ribbon loudspeakers are set to "small."
- If the system bass is weak only when playing surround sources, check that your processor is correctly set to decode the surround modes, such as Dolby Digital or DTS.
- Some DVD discs have a menu that allows you to select which soundtrack to play. Check that the correct surround audio soundtrack is selected.

Limited Warranty

Sunfire, LLC is proud of its products which have been built with care using advanced technology and premium component parts. Your unit has been crafted to perform properly for many years. Sunfire, LLC offers the following Warranty to you, the owner of a new Sunfire product:

The Sunfire Warranty for the XT-Series Cinema Ribbon CRW loud-speaker is in effect for FIVE years from the date of original retail purchase. The Sunfire Warranty covers defects in materials and workmanship. The following, however, are excluded:

- a) Damage caused during shipment.
- b) Damage caused by accident, misuse, abuse of operation contrary to the instructions specified in the Sunfire user's manual
- c) Units where the serial number has been defaced, modified or removed,
- d) Damage resulting from modification or attempted repair by any person not authorized in writing by Sunfire, LLC.
- e) Units purchased from unauthorized dealers.

The Sunfire Warranty extends to the original owner during the five year warranty period so long as the original dated purchase receipt is presented whenever warranty service is required.

All implied warranties, including warranties or merchantability and fitness for particular purposes, are limited in duration to the five year length of this Warranty, unless otherwise provided by state law.

Sunfire, LLC's liability is limited to the repair or replacement, at our option, of any defective product and shall not in any event include property or any other incidental or consequential damages which may result from the failure of this product.

Some states do not allow limitations on how long an implied warranty lasts and/or do not allow the exclusion or limitation of incidental or consequential damages, so the above limitations or exclusions may not apply to you.

This Warranty gives you specific legal rights, and you may also have other rights which vary from state to state. We suggest that you attach your purchase receipt to this Warranty and keep these in a safe place. Thank you for your choice of a Sunfire, LLC product.

Service Assistance

We suggest that you read the Limited Warranty completely to fully understand your Warranty/Service coverage.

If your Sunfire product ever requires service, write to us, or call:

Sunfire, LLC
Technical Services Department
P.O. Box 1589
Snohomish, WA 98290
support@sunfire.com
Tel (425) 335-4748
Fax (425) 335-4746

You will be directed to an authorized Sunfire Service Station or receive instructions to ship the unit to the factory. Please save the original shipping carton and packing materials in case shipping is required. Please do not ship Parcel Post.

NOTE: Before sending in your unit for repair, you must call Sunfire for return authorization (RA).

Include a complete description of the problem, indicating how you have it connected, the associated equipment in your system and a copy of your purchase receipt. Initial shipping costs are not paid by Sunfire, LLC; return ground shipping costs will be prepaid if repairs were covered by the scope of this Warranty.

Sunfire™

XT
SERIES

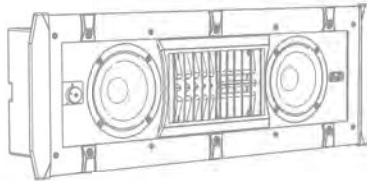
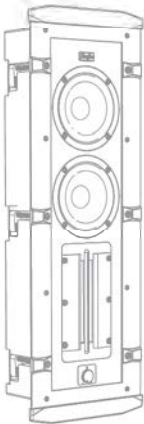

*Cinema Ribbon
In-Wall Loudspeakers
CRW-2 and CRW-2C*

*Sunfire, LLC
P.O. Box 1589
Snohomish
WA 98291*

*Tel (425) 335-4748
Fax (425) 335-4746
www.sunfire.com*