



**AVAILABLE AT
DIGITAL CINEMA**

Assembly Instruction Manual

MODEL NO.: NOVA1800

TAURIS
www.rvm.com.au

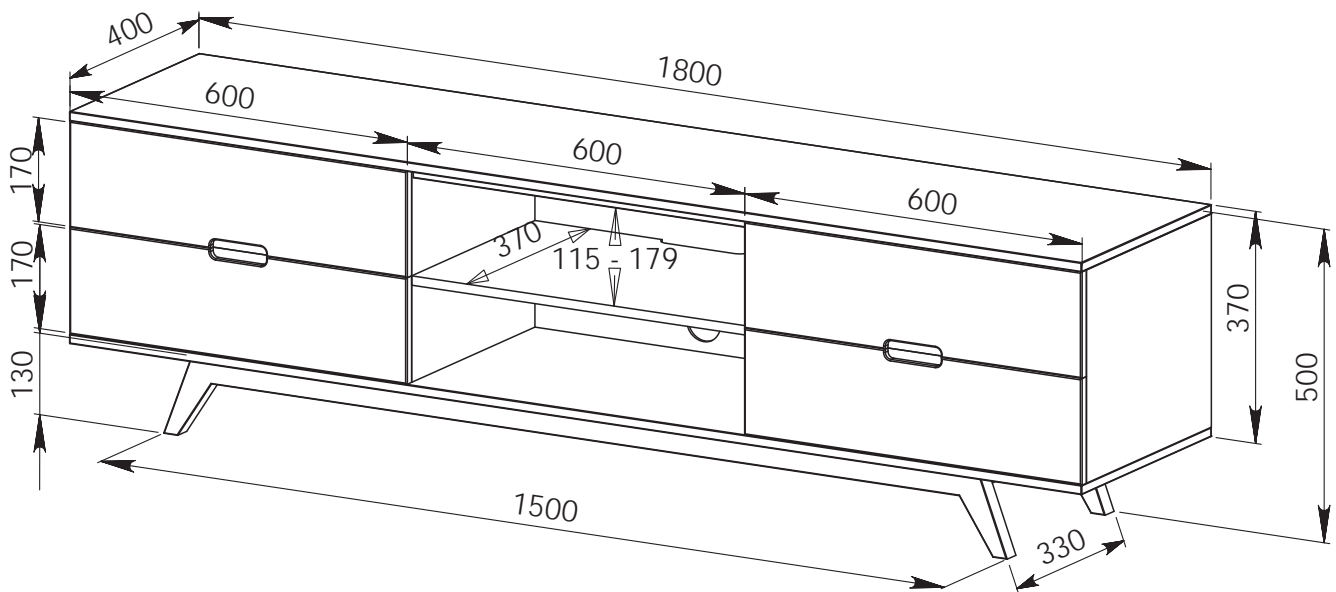









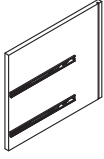
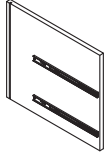
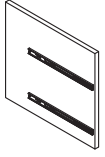
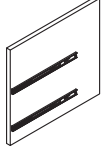
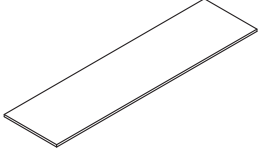
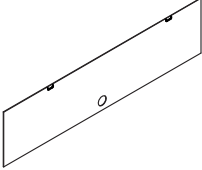
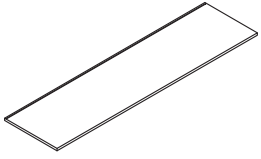
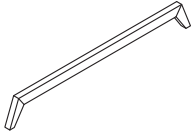
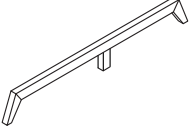
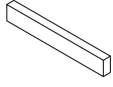
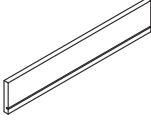
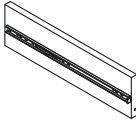
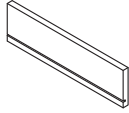
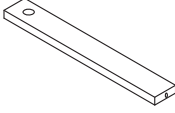
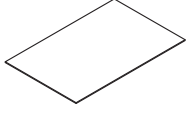
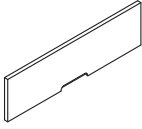
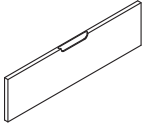
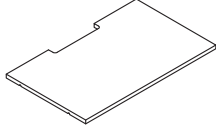
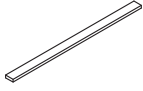





-
- Please follow these assembly instructions as it will save you time, make assembly easier and prevent possible damage to your new unit.
 - We strongly recommend that the unit is assembled on a soft surface such as carpet or blanket.
 - We suggest the use of hand tools only to tighten all screws and fittings, as power tools can strip threads if over tightened.
 - Correct assembly is your responsibility.
 - **When moving this furniture item, always carry the unit. Dragging or sliding the unit could damage the unit and the floor surface.**
-

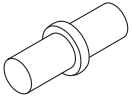

Part List:

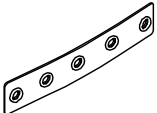
NOTE: PLEASE CHECK YOU HAVE ALL THE CORRECT PARTS LISTED BELOW BEFORE YOU START ASSEMBLING YOUR TV CABINET

<p>① x1pc</p>  <p>Left Hand</p>	<p>② x1pc</p>  <p>Right Hand</p>	<p>③ x1pc</p>  <p>Left Hand</p>	<p>④ x1pc</p>  <p>Right Hand</p>	<p>⑤ x1pc</p>  <p>Top</p>
<p>⑥ x1pc</p>  <p>Cable Management</p>	<p>⑦ x1pc</p>  <p>Base</p>	<p>⑧ x 1pc</p>  <p>Front Leg</p>	<p>⑨ x 1pc</p>  <p>Rear Leg</p>	<p>⑩ x3pcs</p>  <p>Cross Rail</p>
<p>⑪ x4pcs</p>  <p>Drawer Back</p>	<p>⑫ x4pcs</p>  <p>Left Hand</p>	<p>⑬ x4pcs</p>  <p>Right Hand</p>	<p>⑭ x4pcs</p>  <p>Drawer Support</p>	<p>⑮ x4pcs</p>  <p>Drawer Base</p>
<p>⑯ x2pcs</p>  <p>Drawer Front Upper</p>	<p>⑰ x2pcs</p>  <p>Drawer Front Lower</p>	<p>⑱ x1pc</p>  <p>Shelf</p>	<p>⑲ x1pc</p>  <p>Support</p>	<p>⑳ x30pcs</p>  <p>CAM Nut</p>
<p>㉔ x30pcs</p>  <p>CAM Bolt</p>	<p>㉕ x16pcs</p>  <p>∅8x30 Dowel</p>	<p>㉖ x30pcs</p>  <p>∅4x40</p>	<p>㉗ x8pcs</p>  <p>∅4x16</p>	<p>㉘ x6pcs</p>  <p>Washer</p>
<p>㉙ x6pcs</p>  <p>Nut</p>	<p>㉚ x6pcs</p>  <p>∅8x55 Threaded Bar</p>	<p>㉛ x1pc</p>  <p>Spanner</p>	<p>㉜ x8pcs</p>  <p>∅6x40</p>	<p>㉝ x4pcs</p>  <p>Shelf Support</p>
<p>㉞ x3pcs</p>  <p>∅6x25</p>	<p>㉟ x2pcs</p> 	<p>㊱ x2pcs</p> 	<p>㊲ x2pcs</p> 	<p>㊳ x2pcs</p>  <p>M4x10</p>

OVERVIEW

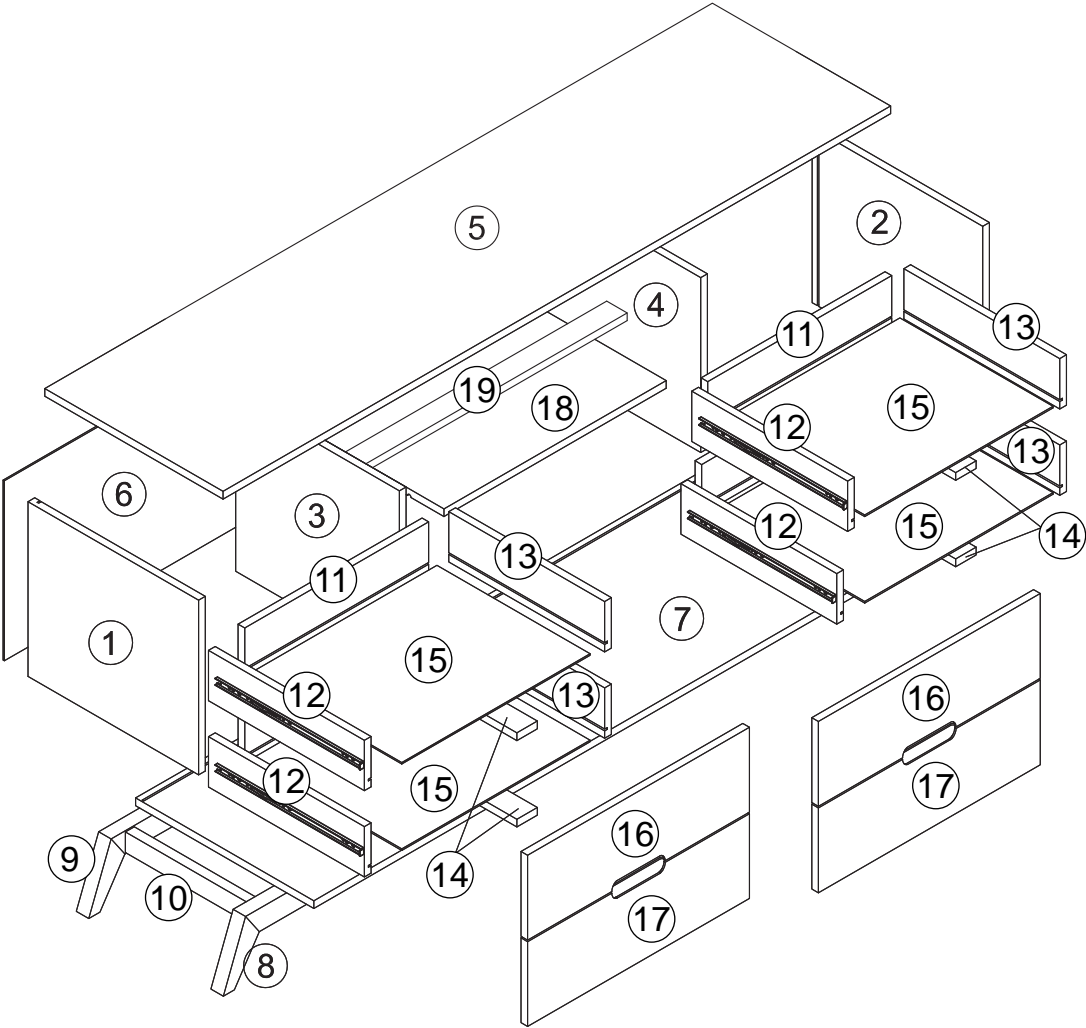

STEP 1

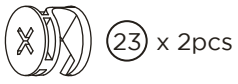

23 x 2pcs



24 x 2pcs

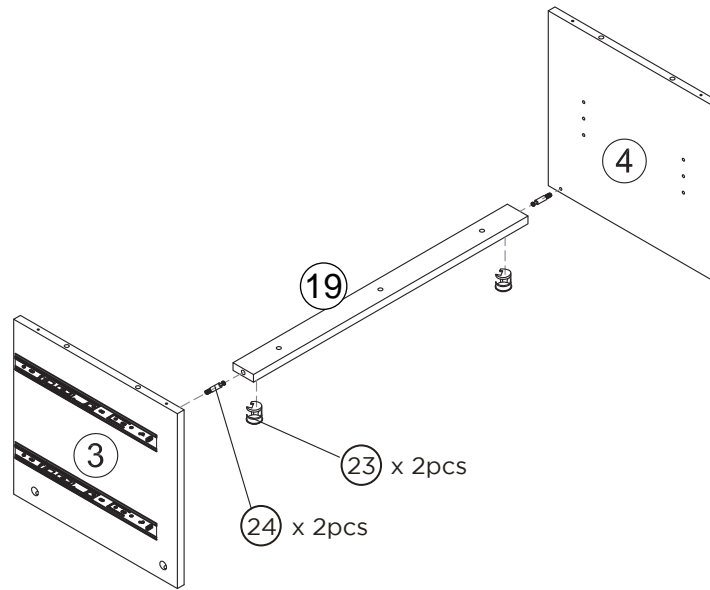

HINT

Cam fitting detail

When inserting cam, ensure arrowhead on cam points toward to the hole on the panel edge.



Arrowhead

STEP 2



23 x 8pcs



24 x 8pcs



25 x 8pcs



34 x 3pcs



27 x 4pcs

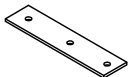

37 x 2pcs

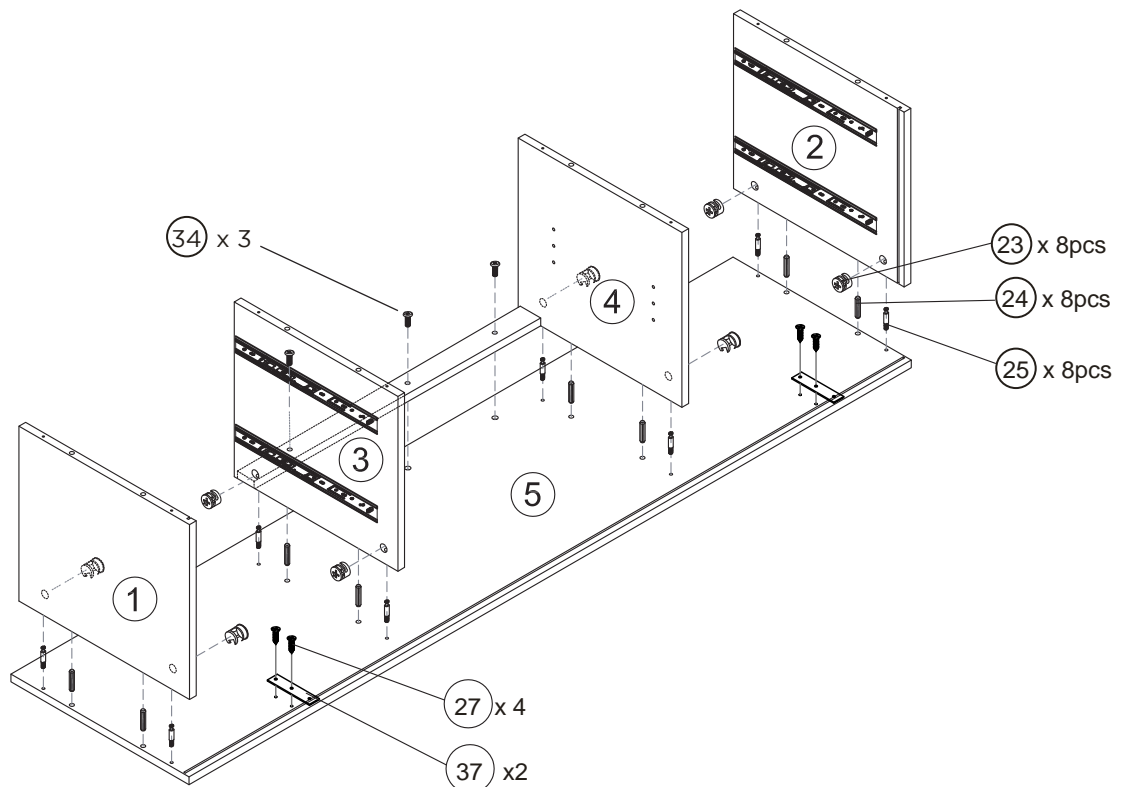

HINT

Cam fitting detail

When inserting cam, ensure arrowhead on cam points toward to the hole on the panel edge.



Arrowhead

STEP 3

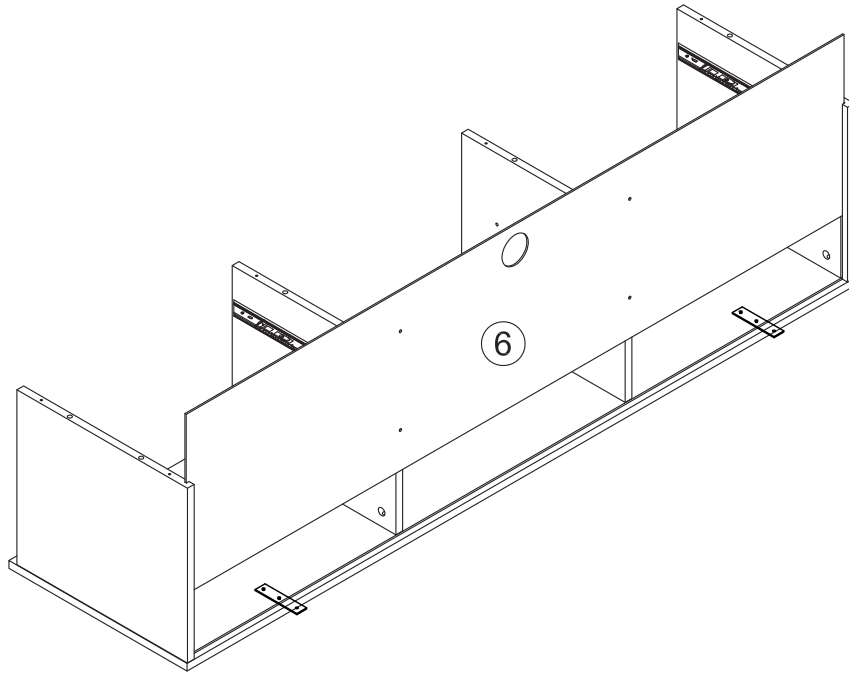

STEP 4



26 x 8pcs



25 x 8pcs

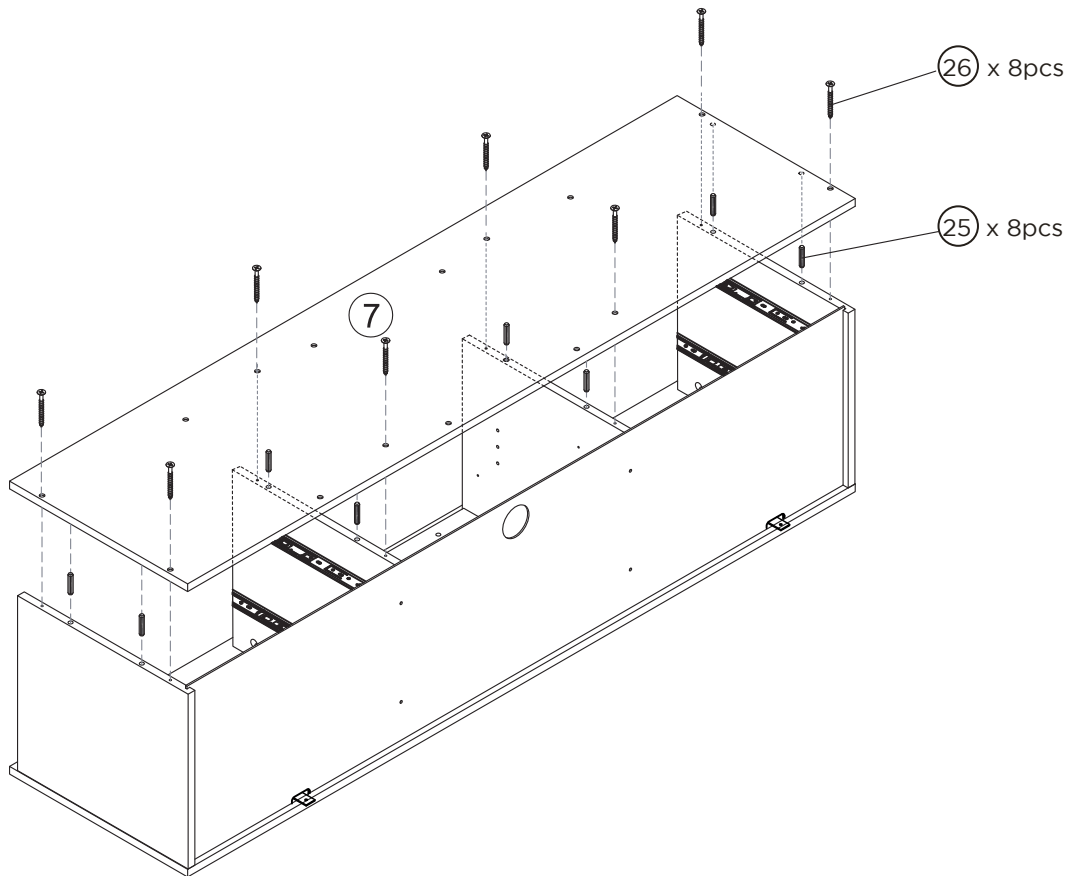

STEP 5

1. HAND TIGHTEN THREADED BAR(30) INTO THE LEG FITTING FIRST
2. SLIDE CROSS RAIL(10) ONTO THREADED BAR(30)
3. TIGHTEN NUTS WITH THE SPANNER PROVIDED(31)

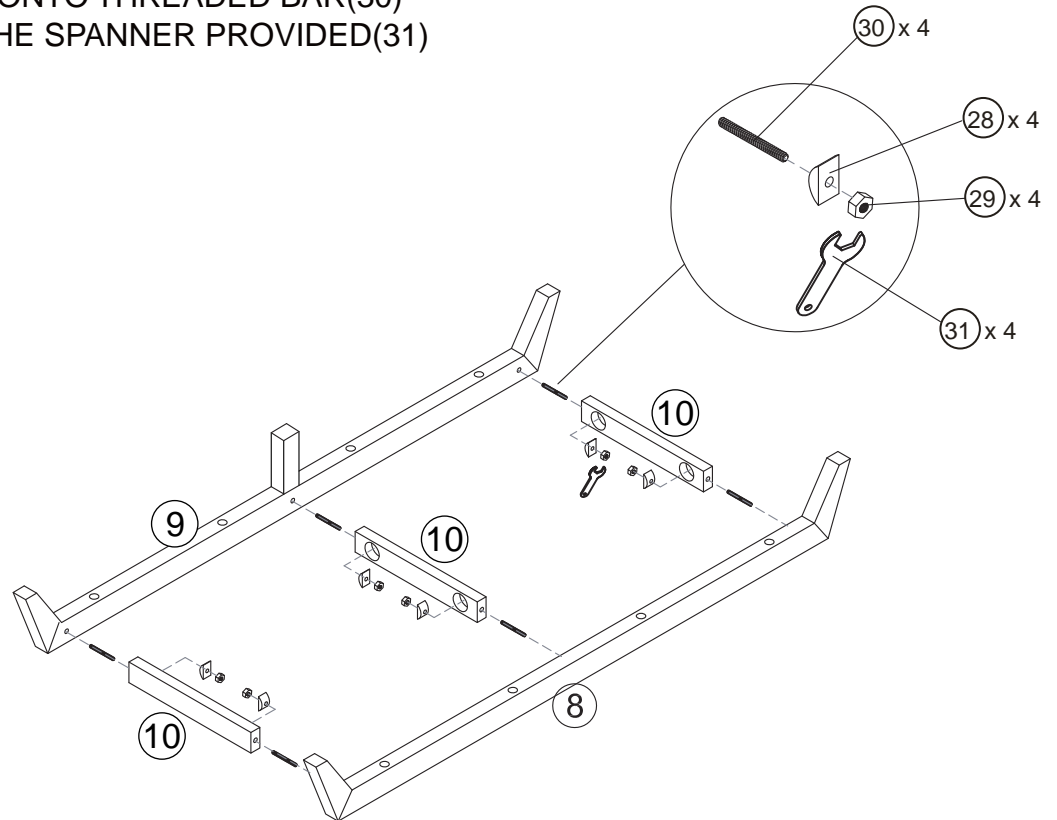

STEP 6



32 x 8pcs

- ALIGN AND LIGHTLY TIGHTEN ALL 8 SCREWS BEFORE FULLY TIGHTENING ALL SCREWS ENSURE LEG WITH EXTRA SUPPORT IS PLACED AT THE BACK OF THE CABINET

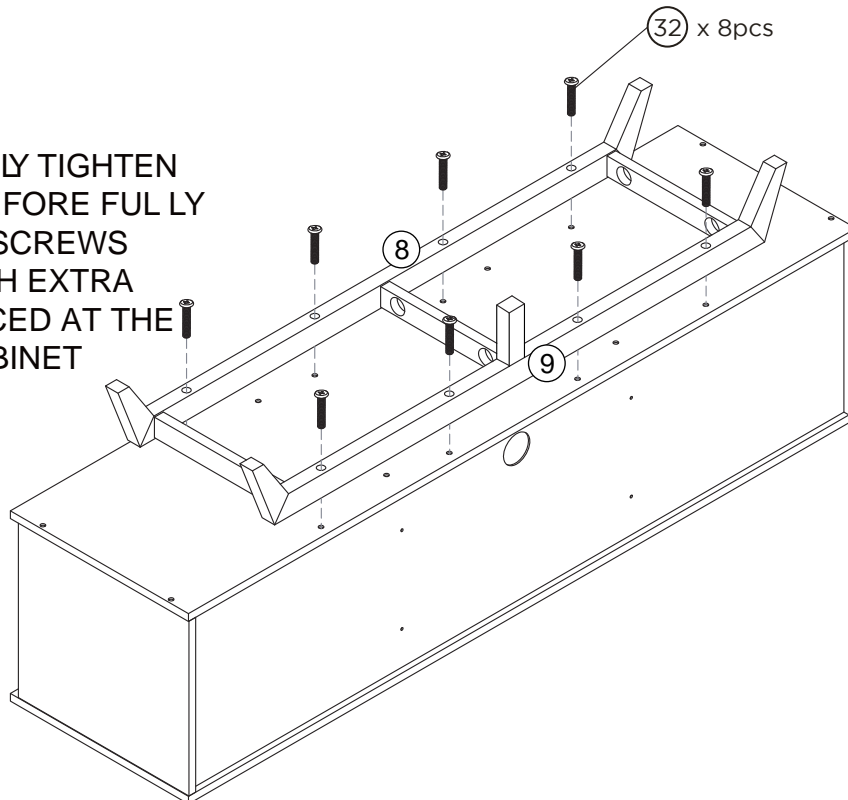

STEP 7 (2 TOP DRAWERS) -NOTE HANDLE GROOVE POSITION

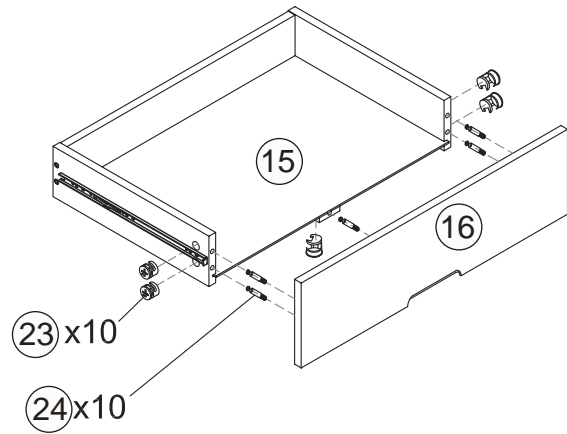
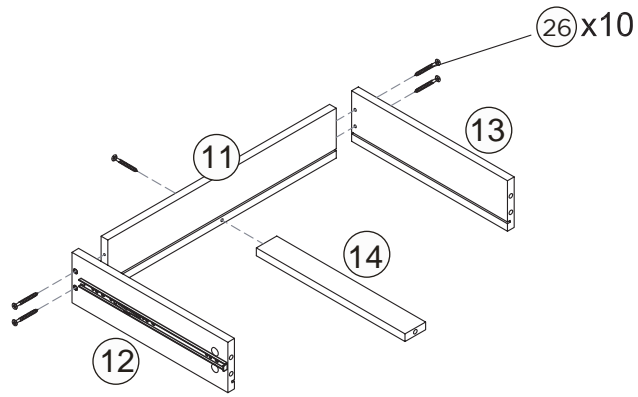
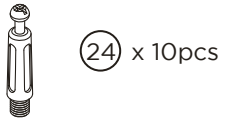
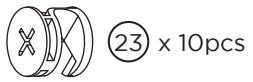

Cam fitting detail

HINT

When inserting cam, ensure arrowhead on cam points toward to the hole on the panel edge.



STEP 8 (2 BOTTOM DRAWERS)

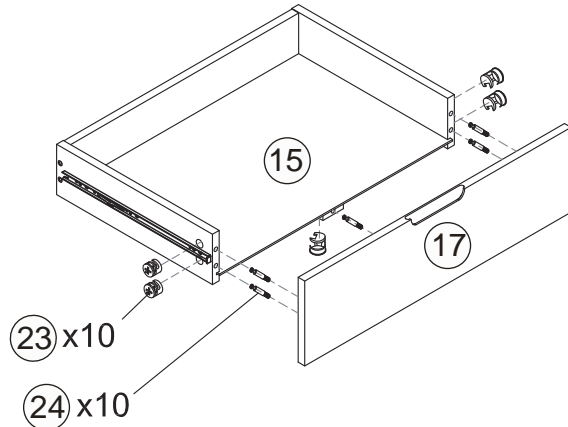
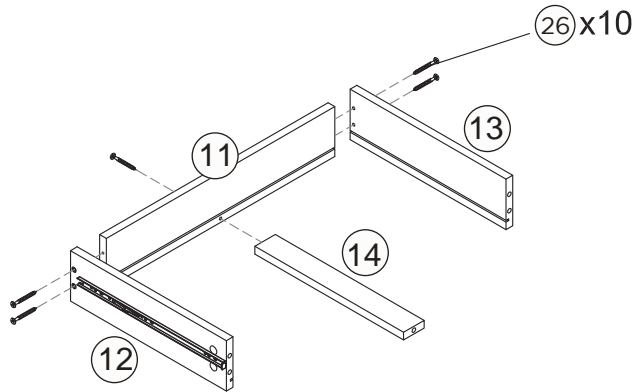
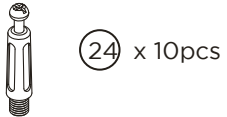
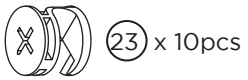

Cam fitting detail

HINT

When inserting cam, ensure arrowhead on cam points toward to the hole on the panel edge.



STEP 9

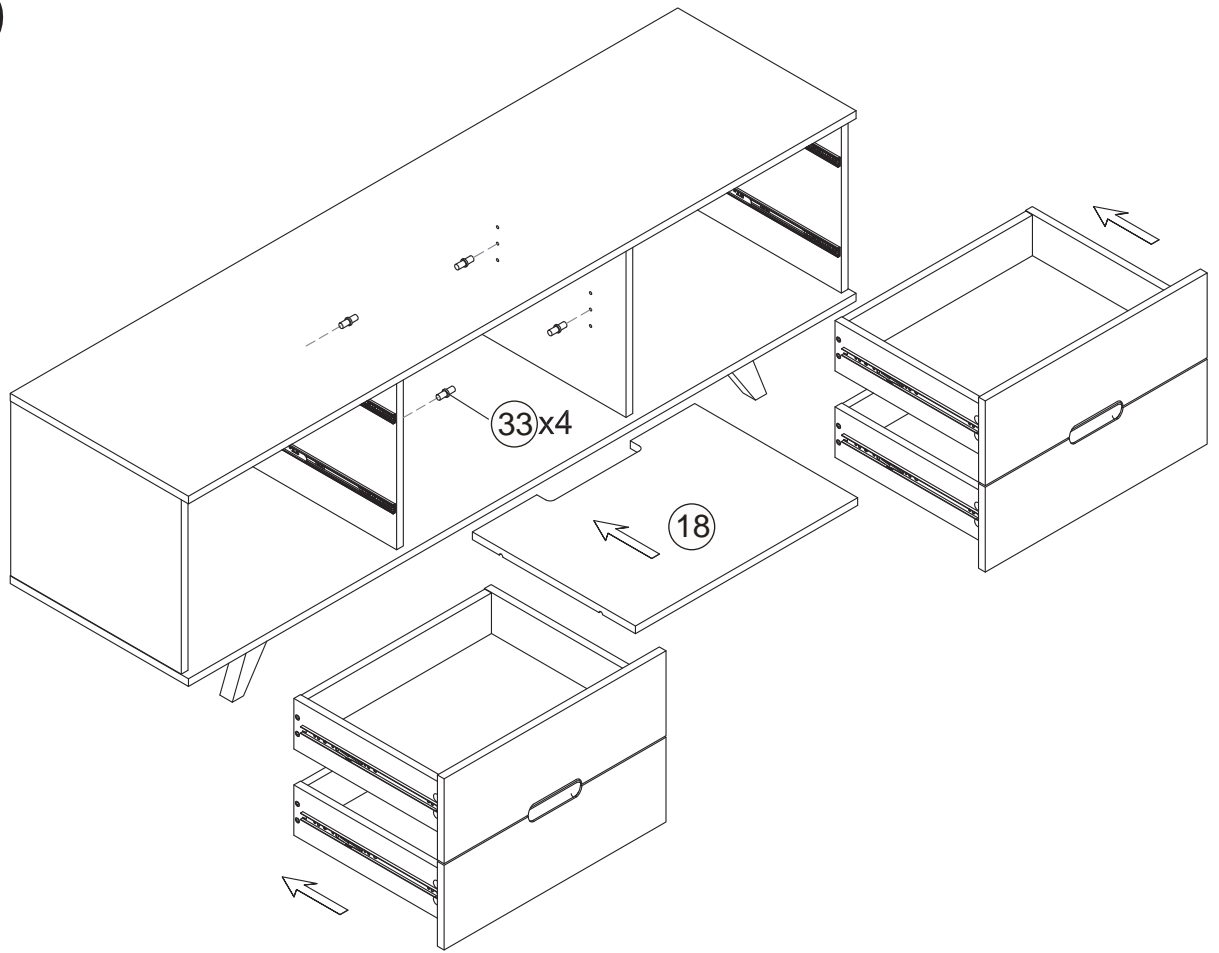

STEP 10

 (27)x 4pcs

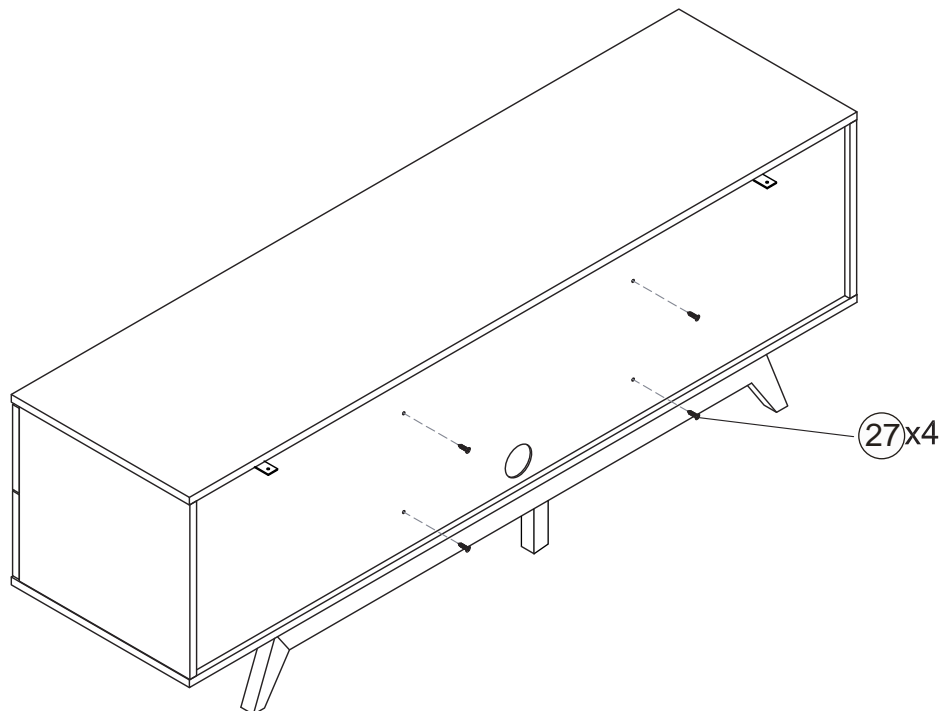

STEP 11



39 x2pcs

NOTE: For gyprock walls ensure you locate the studs, or use appropriate fixings to attach the straps to the wall. (also see Step 12)

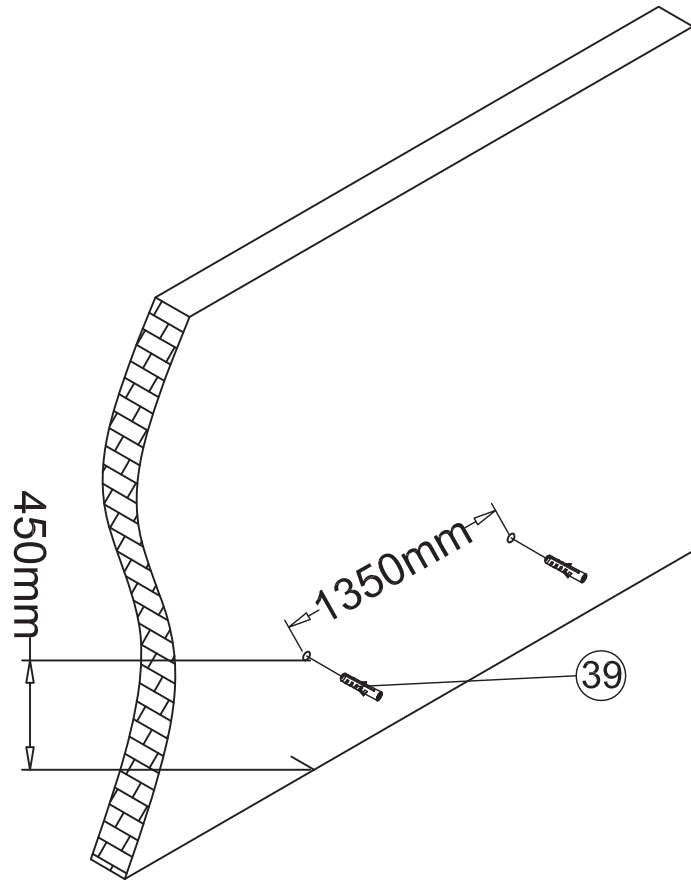

STEP 12

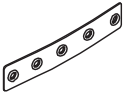

38 x2pcs



26 x2pcs



Use a screw driver to fasten the screws (Part 26) into the wall.

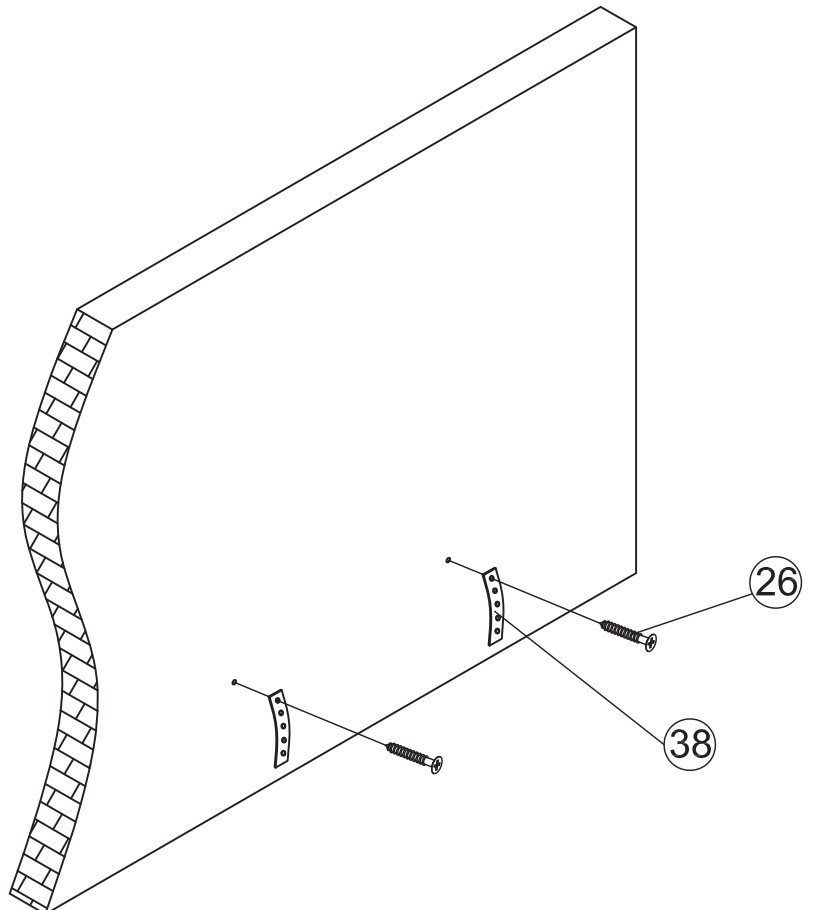

STEP 13



④① x2pcs



Use a screw driver to
fasten the screws
(Part 40) into the
bracket.

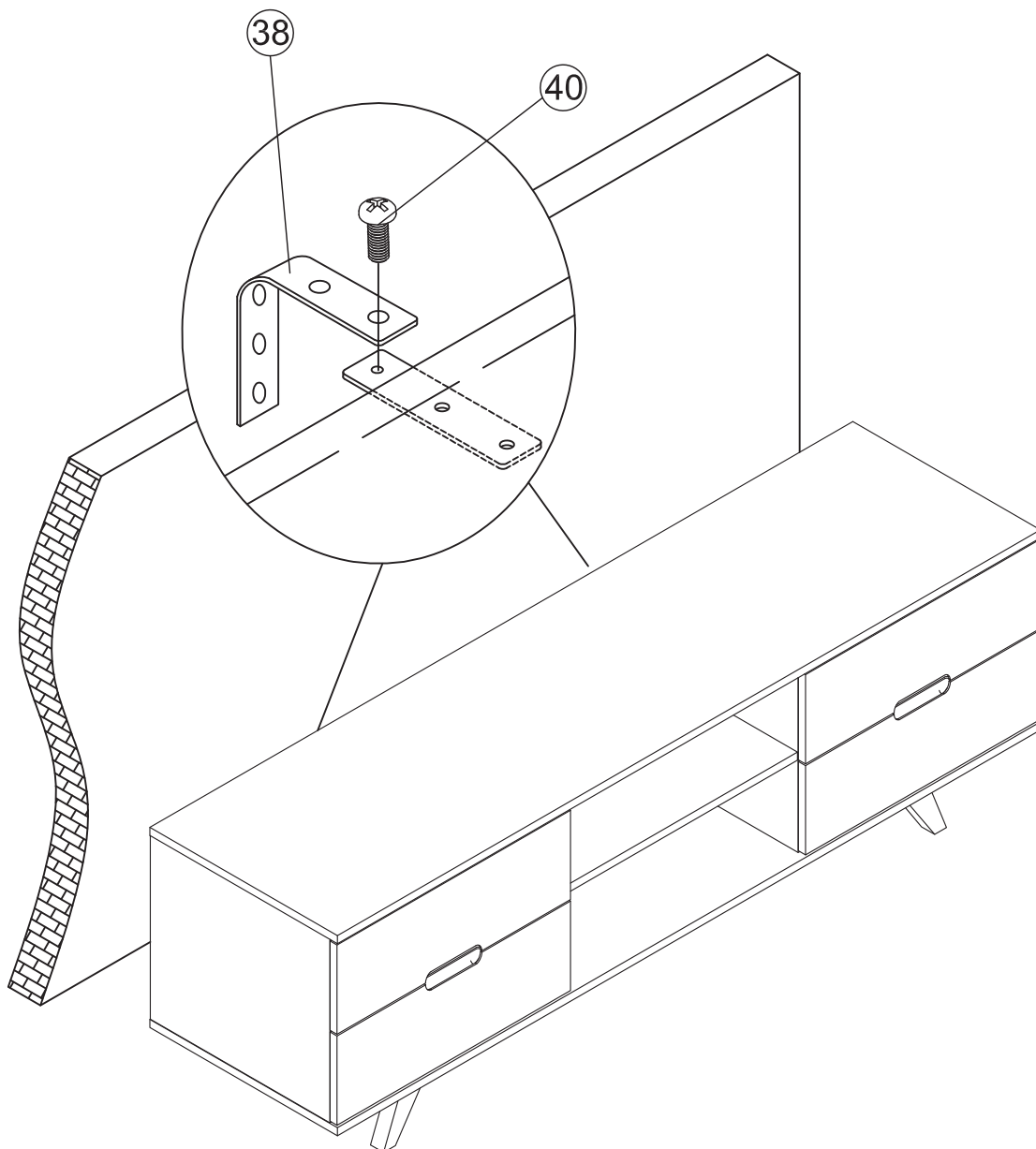

Drawer Front Alignment

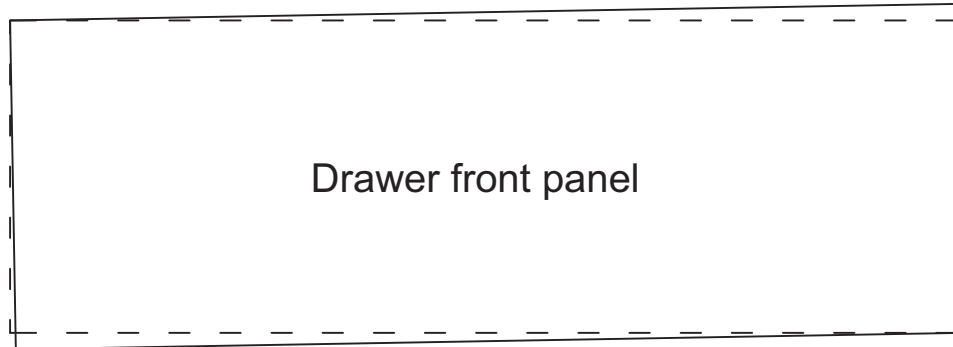

If the drawer front panel is NOT level after being assembled, then...

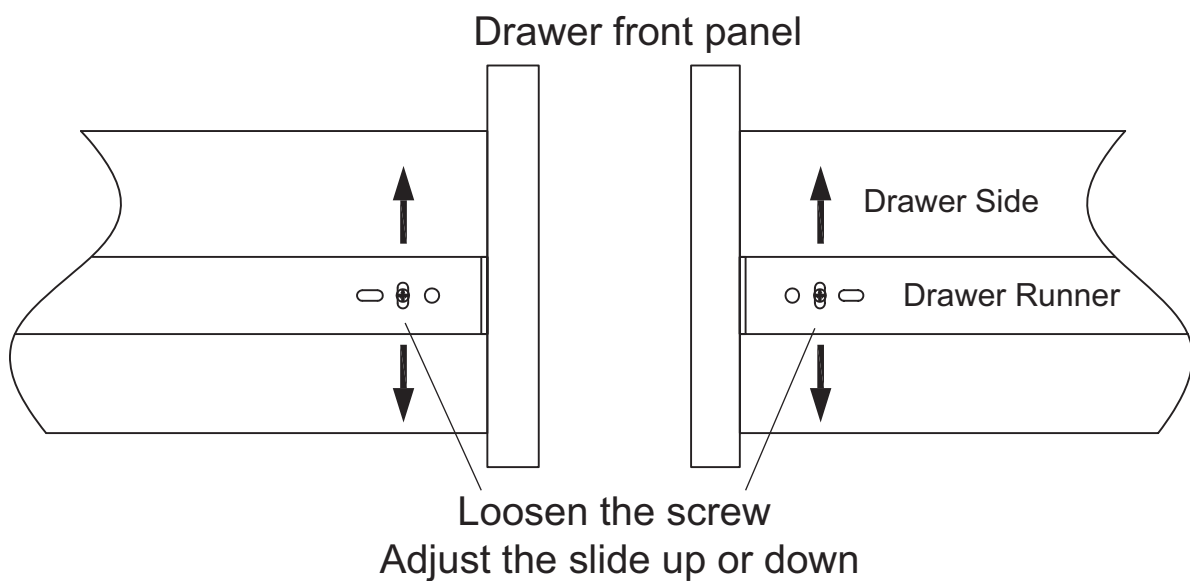

Loosen the screws on the left and right hand side, then move the drawer slide up or down, until the drawer fronts are even/level, then tighten the screws



SURFACE CARE INSTRUCTIONS

A little care and attention will extend the life and good looks of your furniture. Take care when using materials which might spill, or be sharp or abrasive, on the surface of your furniture.

Normal Cleaning: For normal cleaning use a soft, dry, clean cloth.

Glass Cleaning for Frosted Glass: Do not use glass cleaner or solvent based cleaners on glass that has a frosting effect on it.

Normal Glass Cleaning: You may use normal glass cleaning products on all other types of glass. Use a soft non-abrasive cloth to remove light dust and finger prints.

Leather, Vinyl & Speaker Cloth Cleaning: Under no circumstances should any abrasive materials be used on these surfaces, as it will result in irreparable damage.

Do not use solvents, solvent based cleaners, scouring pads, steel wool or scrubbing brushes to clean this furniture item.

Only use a slightly damp, soft, clean cloth on this surface if cleaning is needed. Do not scrub.

CAUTION

As with all furniture, this unit should not be exposed to direct sunlight, extreme temperatures or moisture, as this can result in irreparable damage.

Note: The sooner a spill or mark is cleaned, the easier it will be removed.

Customer Service

FOR ALL MISSING OR FAULTY PARTS: PLEASE RE-CHECK YOUR PACKAGING TO ENSURE THAT PARTS ARE MISSING THEN CONTACT THE STORE YOU PURCHASED THE ITEM FROM.

THE STORE WILL NEED THE FOLLOWING INFORMATION.....

- COPY OF YOUR PURCHASE SLIP/RECEIPT
- MODEL NUMBER OF THE UNIT PURCHASED
- DESCRIPTION/PART NUMBER OF THE MISSING OR FAULTY PART
- QUANTITY OF THE PARTS NEEDED

If for whatever reason you cannot contact the store, please contact Tauris direct at <http://www.rvm.com.au/contact>.

Product of:

RVM Australia
11 Tamara Drive, COCKBURN CENTRAL
Perth, Western Australia 6164
PH: 08 9417 9944



TAURIS

WARRANTY STATEMENT AND POLICY

1. Nothing in this Warranty affects the Consumer's rights under the Australian Consumer law. The benefits to the Consumer under this Warranty are in addition to the rights and remedies of the buyer under any Consumer Guarantees. The Australian Consumer Law requires that we confirm that:

Our goods come with guarantees that cannot be excluded under the Australian Consumer Law. You are entitled to a replacement or refund for a major failure and for compensation for any other reasonably foreseeable loss or damage. You are also entitled to have the goods repaired or replaced if the goods fail to be of acceptable quality and the failure does not amount to a major failure.

2. Subject to Clause 1, the Seller warrants that Tauris branded products will be free of manufacturing defects and will perform to the Seller's specifications subject to the following clauses.
3. The benefit of this Warranty extends only to the owner of the property in which the Products manufactured or supplied by the Seller are installed and used by the owner for the duration of the Warranty Period.
4. The Warranty commences on the date of the purchase of the product and continues for the benefit of the Owner for the Warranty Period. If within the Warranty Period a manufacturing defect is discovered in the Product, or the Product fails to perform to the Seller's specifications as a result of some defect in material or workmanship in the Product, then the Seller will at its own discretion:
 - a.) Repair or replace the Product at the cost of the Seller, including but not limited to labour and travel costs. Goods repaired or replaced under this Warranty will be warranted for the remaining period of the Warranty.
 - b.) Refund the purchase price paid by the consumer.
5. The Warranty does not apply to Product that :
 - a.) Has failed due to excessive wear and tear beyond what is considered to be reasonable.
 - b.) Has been misused or neglected.
 - c.) Was been damaged accidentally or by acts of God including fire and flooding.
 - d.) Has been used or operated contrary to operating or maintenance instructions.
 - e.) Has been damaged by the Consumer or a third party authorised to act for the consumer in transit from the Sellers store to the Consumer.
6. In order to make a claim under the Warranty, the Owner must, where possible return the goods to the Seller's store at the Owner's cost. Proof of purchase must be supplied in all cases.



TAURIS

7. The seller will examine any returned Products and if the Seller determines that there is an apparent defect through no fault of the Owner, the Seller will:
 - a.) Make note of the Owner's contact details including the Owner's telephone number which the owner can be contacted during business hours, postal address and e-mail address.
 - b.) Make note of the defects reported by the Owner.
 - c.) Take back the defective goods from the owner and determine within a reasonable time through dialogue with the Seller whether the goods are defective.
 - d.) Advise the owner within a reasonable time frame whether it accepts or rejects the Product claim.
 - e.) If the Seller accepts the return of the Product, the Seller must arrange to have
 - i) The Product repaired or,
 - ii) Replace the damaged or faulty Product or,
 - iii) Refund the purchase price.

8. The Seller will not accept any returned Product which has not been returned strictly in accordance with this Warranty.

9. For the purpose of this Warranty:
 - a.) Australian Consumer Law means the law as set out in Schedule 2 of the Competition and Consumer Act 2010 (Cth).
 - b.) Consumer means the Purchaser of goods from the seller.
 - c.) Consumer means a Consumer as that term is set out in section 3 of the Australian Consumer Law.
 - d.) Consumer Guarantees means the guarantees under the Australian Consumer Law.
 - e.) Implied terms means any guarantees, conditions, warranties or other terms implied by any Australian Commonwealth, State or Territory laws, (excluding the Australian Consumer Law) or the law of any other jurisdiction.
 - f.) Owner has the meaning set out in clause 3.
 - g.) Warranty means this warranty.
 - h.) Product means the Product/s bought by the Owner from the Seller that fall under this warranty.
 - i.) Warranty Period means:
 - i) In relation to Furniture: 12 months Limited Warranty