



**AVAILABLE AT
DIGITAL CINEMA**



Affordable, high-quality audio everywhere.

Speakers from Bowers & Wilkins have always been recognised as delivering the best audio experience at any level. Techniques and materials honed to perfection in our core models have been successfully carried over to our custom products, so that those who want to hear everything whilst seeing nothing have had a clear solution. That is unless the environment is one of high humidity, such as a shower room or indoor swimming pool, which are unsuited to some of the advanced materials we have employed.

All change!

The three models in the new CI 300 Series have been specifically designed to cope with these more demanding environments, so whereas their cost effectiveness may lead them to being described as entry level, they also provide a point of entry to areas of the home that were previously off-limits for high-quality installation loudspeakers.

CWM362

The CWM362 is a two-way in-wall loudspeaker. Like the in-ceiling models in the series, it features an elegant minimal-width border design.

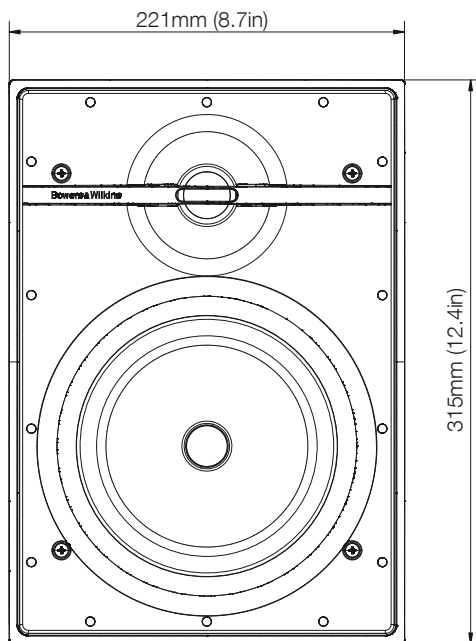

CWM362 Technical Specifications

Description	2-way in-wall system
Drive Units	1x 160mm (6in) Polypropylene cone bass/midrange 1x 25mm (1in) soft dome tweeter
Frequency Range (-6dB)	50Hz - 30kHz
Sensitivity SPL (2.83V, 1m)	89dB
Impedance Nominal (min)	8Ω (5.0Ω)
Power Handling	80W
Pre-mount Kit	PMK W6
Back Box	BB 6W

