

# Ci130QSfl



## Architectural Speaker

OBSESSED WITH HIGH RESOLUTION



**AVAILABLE AT  
DIGITAL CINEMA**

### Product Overview

The KEF Ci130QSfl is a flush-mounted frameless architectural speaker featuring an easy installation process. Designed for both new construction and retrofitting, Ci130QSfl becomes flush with the wall or ceiling – ideal for current design trends of clean lines and minimalist features. Not only does Ci130QSfl deliver visually, but it features all of the acoustic technologies that makes the Ci-Q Series an ideal choice for bringing high quality sound into any room.

Built around KEF's signature Uni-Q driver array, combining a 130mm (5.25in.) midrange driver and 19mm (0.75in.) tweeter, Ci130QSfl acts as a single point source that delivers natural sound throughout the room, eliminating the narrow 'sweet spot.'

The Ci130QSfl is presented in a square format, whilst the Ci130QRfl is identical in terms of driver size and technology, but in a round format.

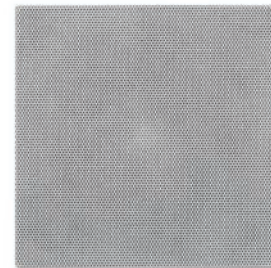

### Key Features

**KEF "Sit Anywhere" Uni-Q® Technology** – This proprietary driver array places the tweeter in the acoustic centre of the woofer delivering wide dispersion with consistent sound characteristics throughout the room. Because the high and low frequencies originate from the same point in space, acoustic lobing problems common to other speaker designs are virtually eliminated and imaging is greatly improved to effectively shift the sound to appear as if it's originating from behind the video screen.

**Tangerine Waveguide™** – In addition to protecting the driver, the Tangerine Waveguide further enhances dispersion allowing for coverage of any seating position.

**Flush Mount Installation** – Frameless design provides seamless integration with the wall or ceiling.

**Uni-Q Driver Array** – With 130mm (5.25in) MF/LF driver and 19mm (0.75in) HF driver.

**Easy to Install** – Ci130QSfl is easy to install as part of the plastering process.

**Magnetic Grille** – For security and ease of installation, the grille attaches by a powerful magnetic circuit and can be painted to match any décor.

**Gold-Plated Spring Loaded Binding Posts** – This design improves ease of installation and guarantees consistent wire clamping pressure to ensure proper electrical transfer.

**Covered Crossover Circuit** – The cover adds structural rigidity to the speaker assembly while protecting the electrical crossover components from potential damage.

**Choice of Formats** – Available in round (Ci130QRfl) and square (Ci130QSfl) formats.



Cross section showing an installed Ci130QSfl

## Specifications

|   |    |   |
|---|----|---|
| Model                                   |    | Ci130QSfl                                       |
| Series                                  |    | FL Series                                       |
| Nominal impedance                       |    | 8Ω  |
| Sensitivity (2.83V/1m)                  |    | 87dB  |
| Frequency response (±6dB) open-backed   |    | 45Hz - 34kHz                                    |
| Frequency range (-10dB)"                |    | 38Hz - 30kHz                                    |
| Nominal coverage                        |    | 130°  |
| Max SPL                                 |    | 103dB   |
| Crossover frequency                     |    | 3.8kHz  |
| Drive units                             | LF | 130mm (5.25in.) Uni-Q                           |
|   | HF | 19mm (0.75in.)                                  |
| Recommended amplifier power             |    | 10 - 100 W                                      |
| Recommended high-pass filter            |    | 50Hz  |
| Product external dimensions (H x W x D) |    | 200.5 x 200.5 x 103.6 mm (7.9 x 7.9 x 4.08 in.) |
| Cut-out dimensions (H x W)              |    | 158 x 158 mm (6.22 x 6.22 in.)                  |
| Net weight                              |    | 1.6kg (3.53lbs.)                                |
| Mounting depth from surface             |    | 101mm (3.98in.)                                 |
| Optional rough in frame                 |    | N/A   |
| Optional rear enclosure                 |    | N/A   |
| Ideal rear volume                       |    | 15L   |
| Minimum rear volume                     |    | 10L   |
| Safety and Regulatory Compliance        |    | N/A   |
| Ceiling thickness (Maximum)             |    | 35mm (1.38in.)                                  |
| Ceiling thickness (Minimum)             |    | 9mm (0.36in.)                                   |

# Ci130Qsf1

## Architectural Speaker



OBSESSED WITH HIGH RESOLUTION

### Directivity Index

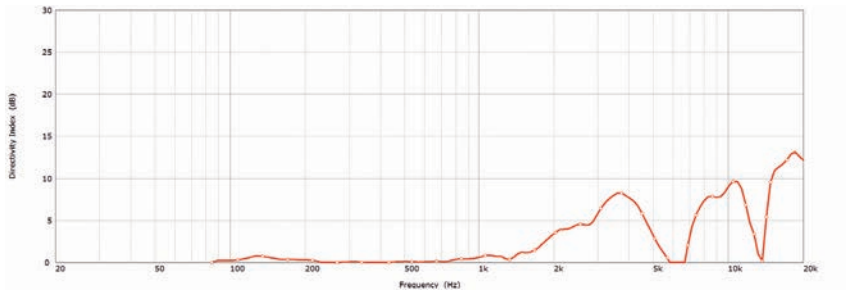

### Beamwidth -3dB

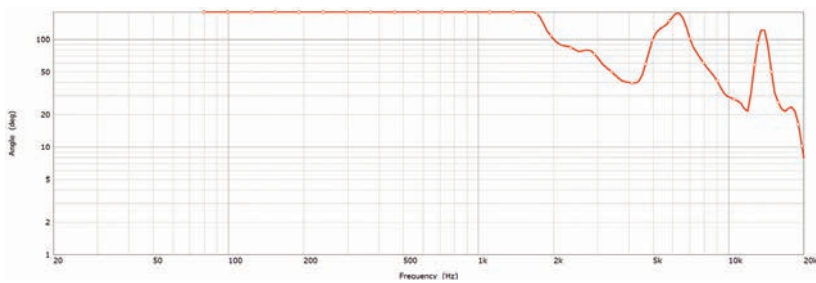

### Beamwidth -6dB

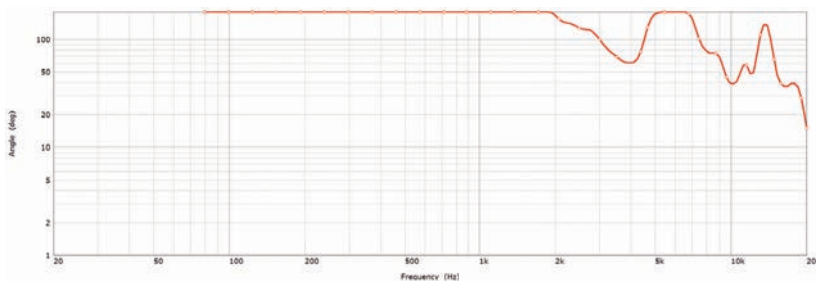

### Impedance

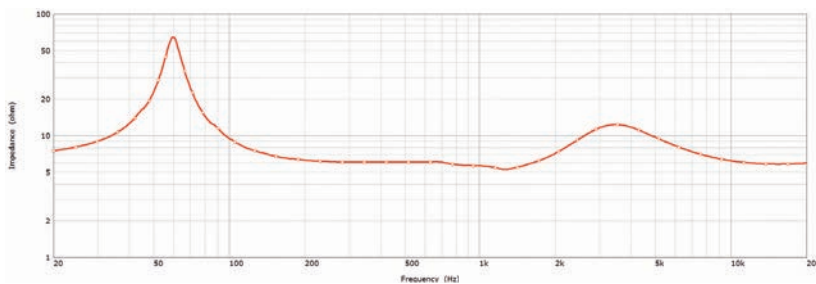

### Sensitivity (2.83V/1m)

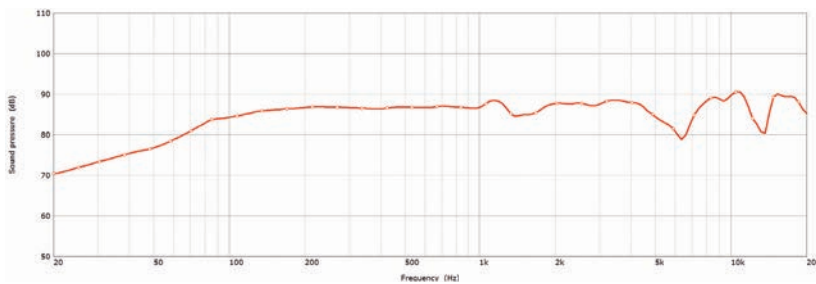

### Polar Responses

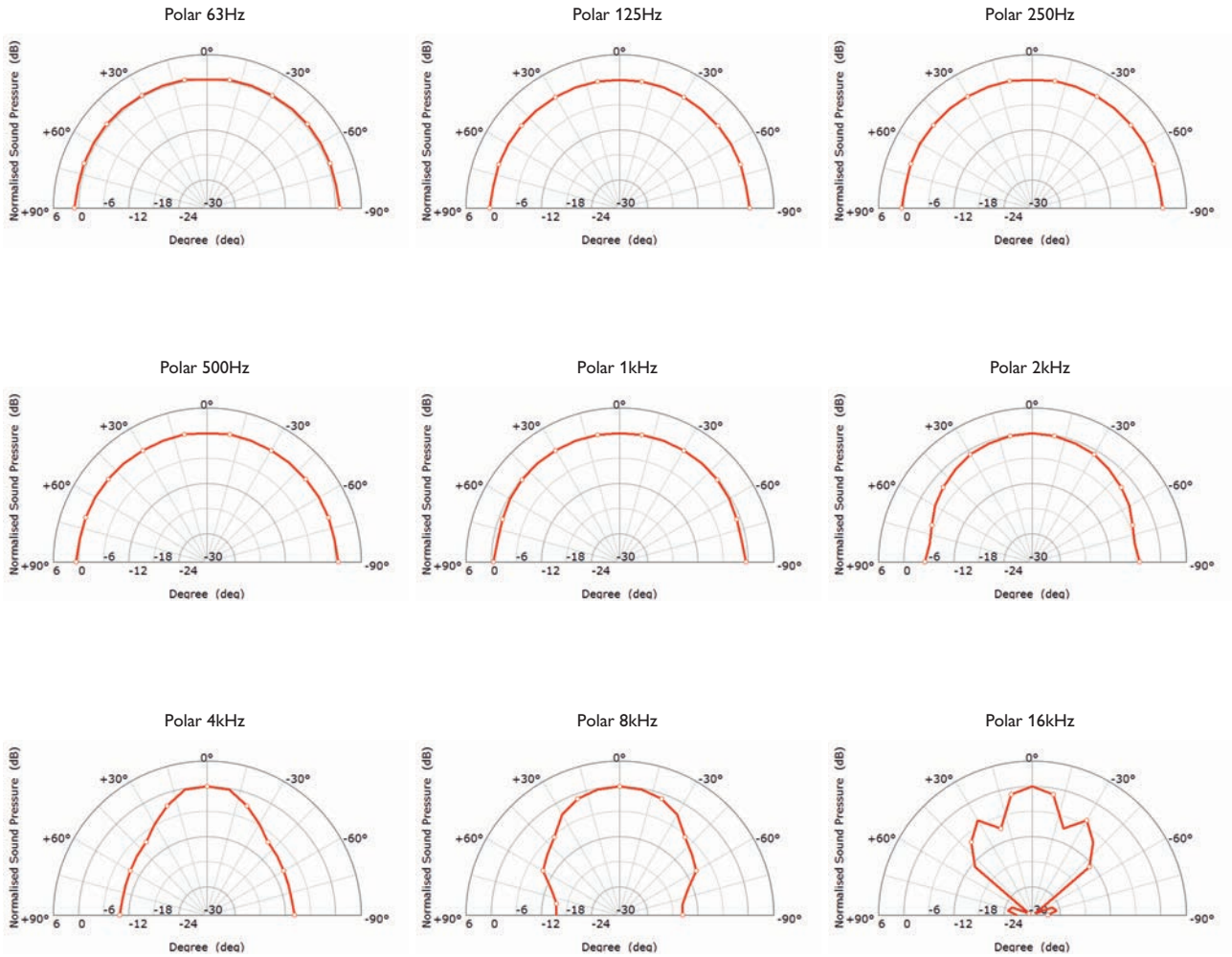

# Ci130QSfl



## Architectural Speaker

OBSSESSED WITH HIGH RESOLUTION

### Mechanical Diagrams

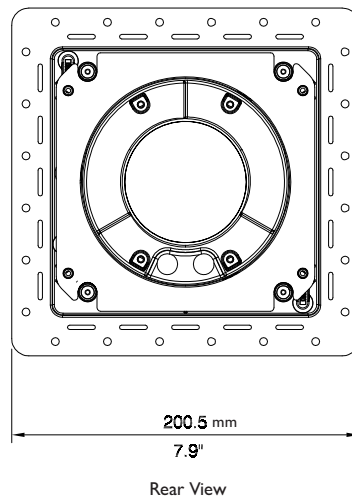
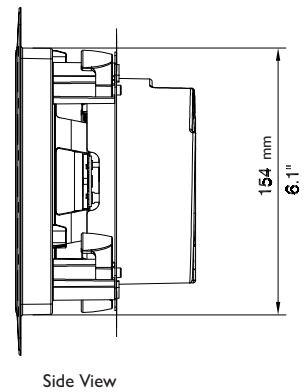
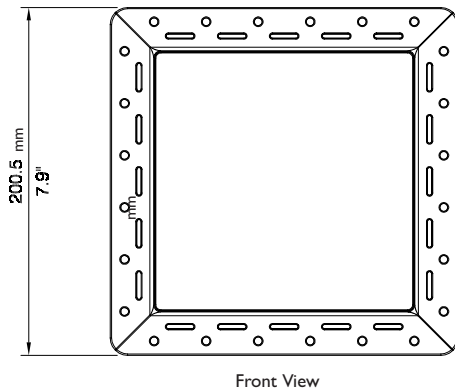
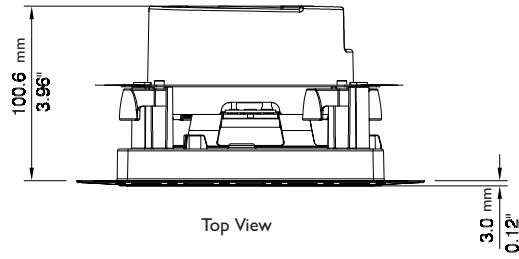

Dimensions in mm (inches)

Visit [KEF.COM](http://KEF.COM) for more about KEF and its products.

KEF reserves the right, in line with continuing research and development, to amend or change specifications. E&OE.