

HIGH POWER DUAL 15" TRAPEZOIDAL LOW FREQUENCY SPEAKER SYSTEM



Designed as the perfect complement to Klipsch's high power, full-range loudspeaker systems, the KI-215 low-frequency enclosure features two K-45-KT cast frame 15" transducers.

These heavy duty components use 104-ounce magnets and 3" voice coils to deliver high sensitivity and advanced power handling capabilities. Utilizing proprietary speaker motor assemblies, the unique design ensures that voice coil formers won't be damaged during extreme cone excursions. Additionally, a low 40Hz cabinet tuning allows electronic equalization to be added for extended response without undue component stress.

Ideal when used in music reinforcement and reproduction environments such as clubs, theaters, auditoriums, churches and performance halls, the 13-ply, Baltic Birch tuned port enclosure applies CNC fabrication techniques for uniform tolerances and build reliability.

Signal connections are provided via two parallel-wired Neutrik NL-4 Speakon panel mount jacks. Built-in flying capability is included using twelve 3/8" 16-thread fly points compatible with most commercially available rigging hardware.

The KI-215's trapezoidal enclosure dimensions and rigging configuration are identical to the KI-362 full-range professional loudspeaker system, making it an ideal match when using an external, active two-way crossover. The KI-215 is also suitable for use with the KI-262 and KI-272, providing smooth power response and improving low-frequency extension.

As with all KI Series speakers, the KI-215 is covered by the Klipsch limited five-year warranty.

KI-215

DIGITAL
CINEMA

AVAILABLE AT
DIGITAL CINEMA

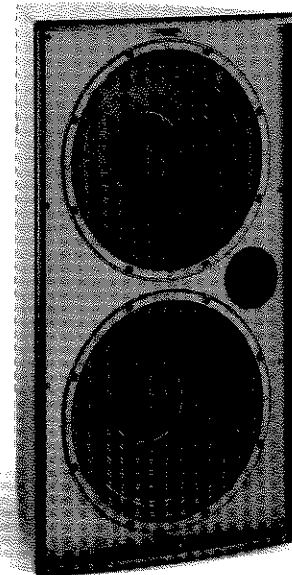

- Compact 22.5° symmetrical trapezoidal design
- High power 15" cast frame woofers
- 105dB half-space sensitivity, 131dB SPL maximum output
- 800-watt power handling capability
- 12 rigging points for simple, reliable mounting
- Compact heavy-duty, 13-ply Baltic Birch enclosure
- Weather-resistant, dual-coat textured black finish
- Dado "lock-tab" and rabbet joint construction

Specifications

FREQUENCY RESPONSE ¹	70Hz-1kHz±4dB, -10dB 57Hz (see graph)
POWER HANDLING ²	800 Watts (56.5V)
MAXIMUM CONTINUOUS OUTPUT ³	131dB
DISPERSION ANGLE	See Graph
DIRECTIVITY	See Graph
SENSITIVITY ⁴	105dB
NOMINAL IMPEDANCE	8 Ohms, 4 Ohms Minimum at 40Hz (see graph)
COMPONENTS	Two K-45-KT 15" Woofers
ENCLOSURE MATERIAL	18mm 13-Ply Baltic Birch Plywood Cabinet 1" 11-Ply Birch Plywood Baffle
INPUT CONNECTIONS	Two NL-4 Speakon Connectors Wired in Parallel
DEPTH	16.5" (41.91cm)
HEIGHT	34.313" (87.155cm)
WIDTH FRONT	19.438" (49.372cm)
WIDTH BACK	6.813" (17.305cm) 22.5° Angled Box
NET WEIGHT	81 lbs. (36.774kg)
SHIPPING WEIGHT	94 lbs. (42.676kg)
FINISHES	Black, White and Raw Birch

¹3M, Half-space anechoic

²AES Standard, continuous pink noise 40Hz-10kHz, 6dB peaks

³Calculated at 1M at power handling power input

⁴SPL at 1M, half-space anechoic with 2.83V input

KI-215

HIGH POWER DUAL 15" TRAPEZOIDAL LOW FREQUENCY SPEAKER SYSTEM

Frequency Response

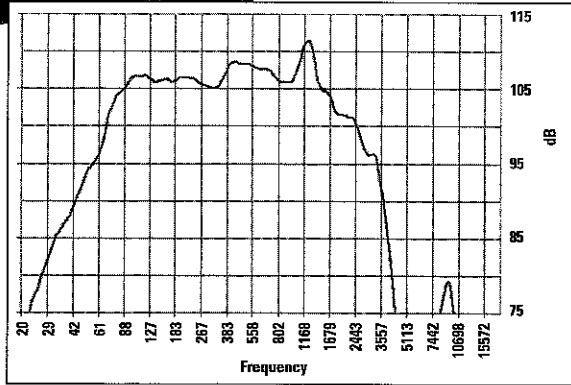

Impedance

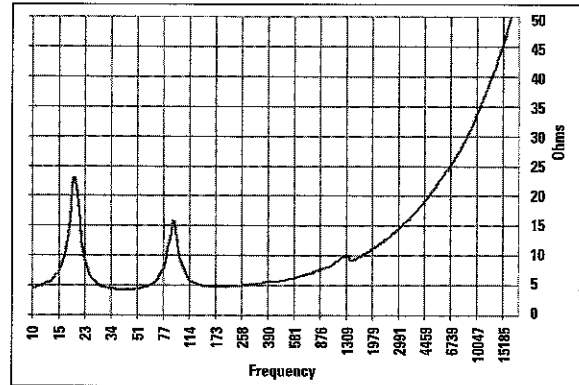

Horizontal Off-Axis Transfer Function

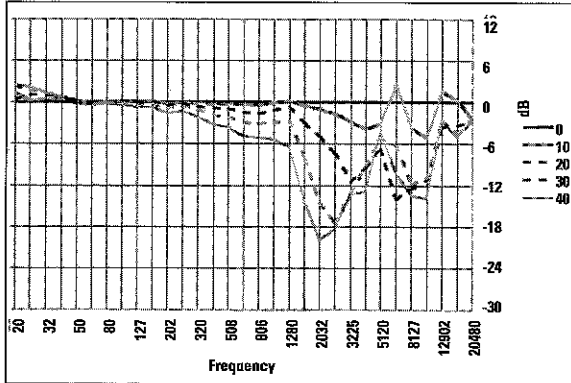

Directivity Index

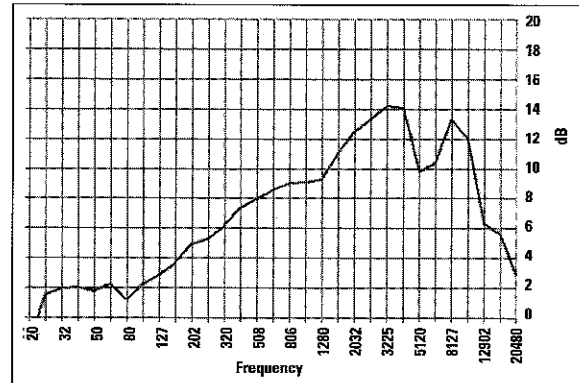

Horizontal Coverage (-6dB)

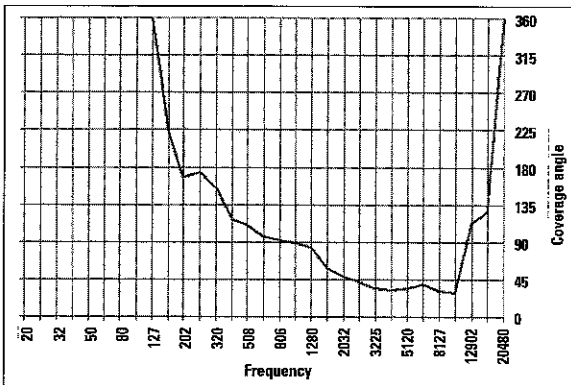

Vertical Coverage (-6dB)

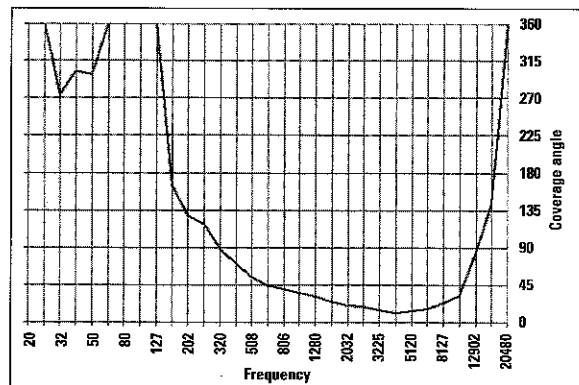

Vertical Off-Axis Transfer Function

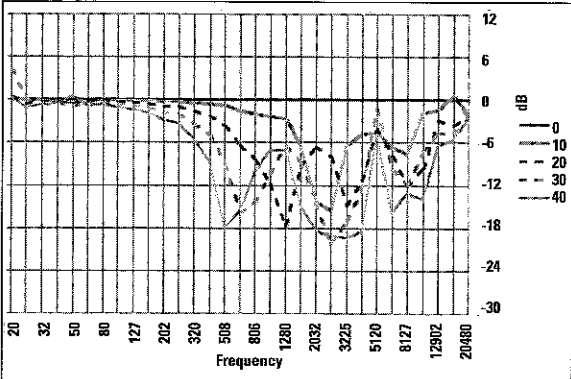

Vertical 1/3 Octave Polars

Horizontal 1/3 Octave Polars

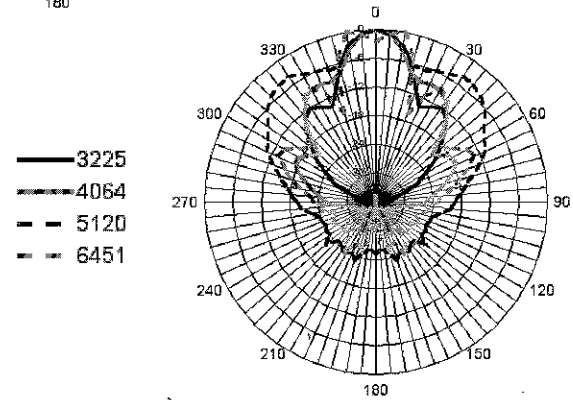
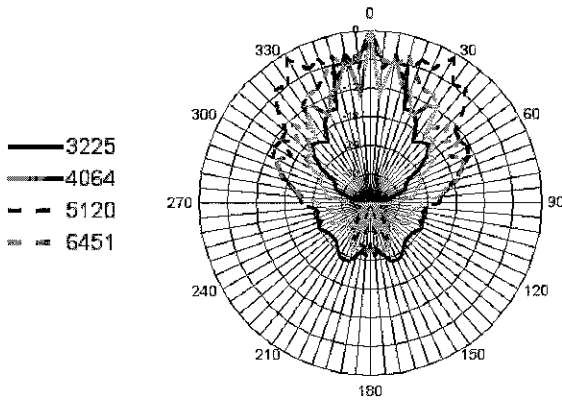
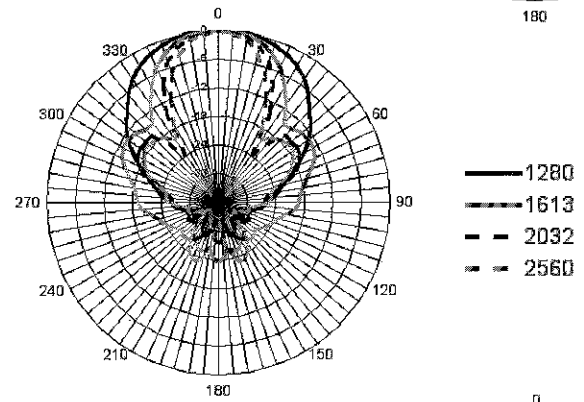
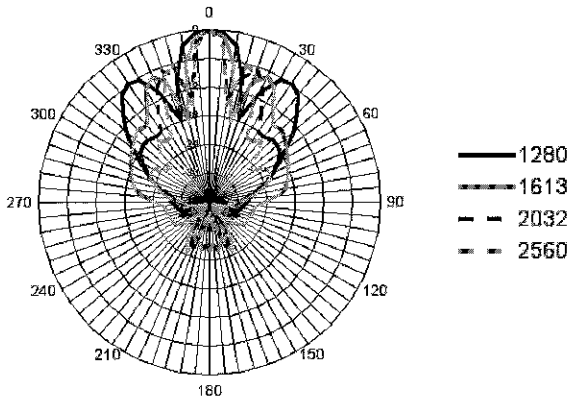
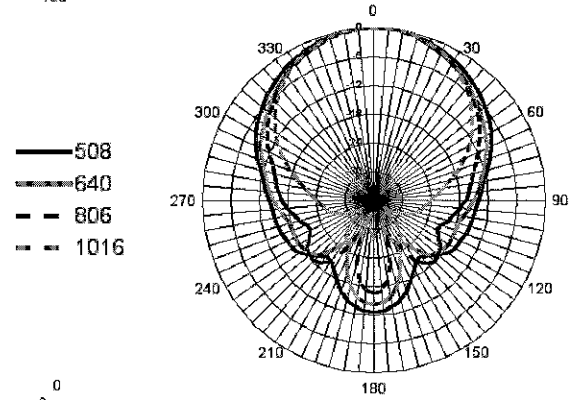
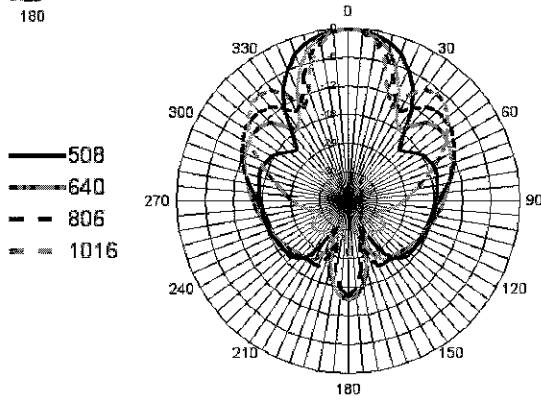
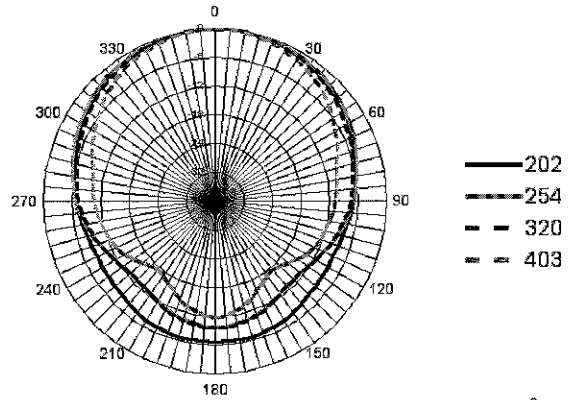
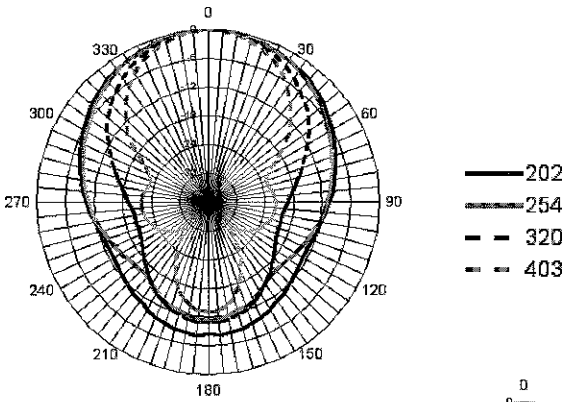

Architectural Specifications

The KI-215 high power dual 15" trapezoidal low-frequency loudspeaker system shall include two 15" (381mm) K-45-KT low-frequency transducers, utilizing 3" (76.2mm) voice coils and 104-ounce (3.23kg) magnets.

Frequency response shall be 70Hz to 1kHz, ± 4 dB, with the -10dB point at 57Hz, measured at three meters, half-space anechoic. Cabinet tuning shall be 40Hz, allowing electronic equalization for frequency extension. Refer to graphs for horizontal and vertical dispersion angles and directivity. Sensitivity shall be 105dB SPL, measured at one meter, half-space anechoic, with a 2.83V input. Power handling shall be 800 watts (56.5 volts), to AES standards, continuous pink noise, 40Hz to 10kHz, 6dB peaks. Calculated maximum continuous output at one meter shall be 131dB SPL. Nominal impedance shall be 8 ohms, with 4 ohms minimum at 40Hz.

Signal connections shall be made via two parallel-wired Neutrik NL-4 Speakon panel mount jacks.

The enclosure panels shall be CNC-fabricated, 18mm, 13-ply Baltic Birch void-free plywood, assembled utilizing rabbet and dado joinery. The motorboard baffle shall be 1" (2.54cm) 11-ply birch plywood. Dimensions for the enclosure shall be 34.313" (87.155cm) high by 16.5" (41.91cm) deep by 19.438" (49.372cm) front width and 6.813" (17.305cm) rear width in a symmetrical trapezoidal shape, with both side panels angled at 22.5°. Net weight shall be 81 lbs. (36.774kg). The top and bottom panels shall be radiused, with a curved metal perforated grille for structural integrity and protection of the transducers from impact and tampering. The enclosure tuning shall be of a vented design.

Enclosure flying capability shall be provided using 12 commercially available rigging bar-compatible internal $\frac{3}{8}$ " 16-thread mounting points, three per top, bottom and both sides.

The enclosure shall be coated with lacquer-based primer and lacquer-based texture, with a black or white finish. The enclosure shall also be available unfinished in raw birch.

The system shall be a Klipsch KI-215 loudspeaker.

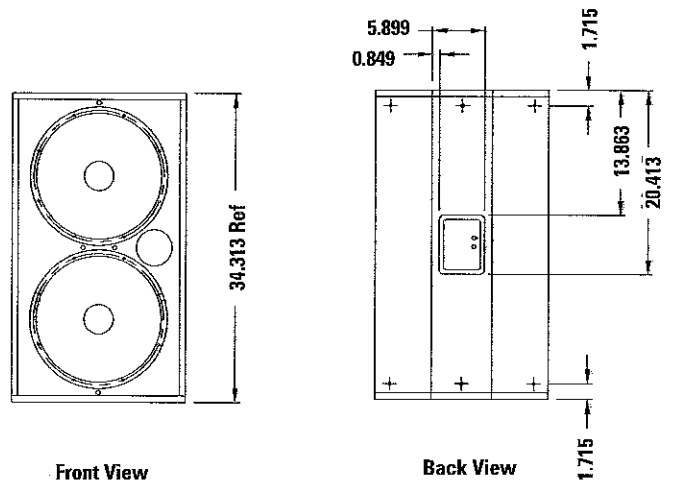

Front View

Back View

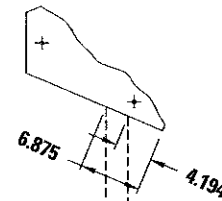

Left Side View

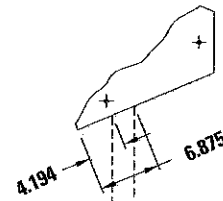

Right Side View

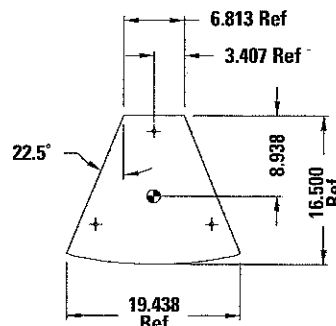
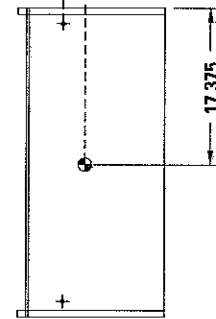
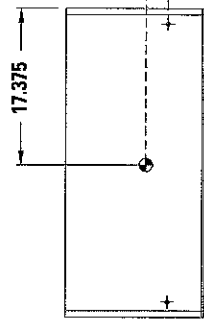

Top View

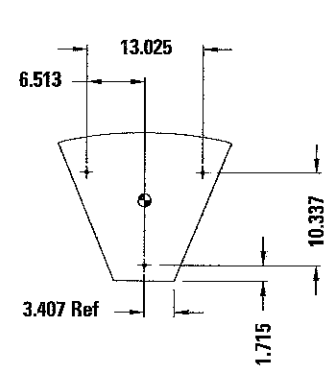

Bottom View

- ⊕ This symbol represents the center of gravity.
- + This symbol indicates mounting point, $\frac{3}{8}$ -16 UNC threaded hole.



8900 Keystone Crossing, Suite 1220
 Indianapolis, IN 46240
 P.O. Box 688
 Hope, AR USA 71802
 1-800-KLIPSCH • www.klipschpro.com