



NAD C 588 Turntable



NAD's is well known for innovative, high performance, yet affordable, turntables. While the basic operation of a turntable seems simple, extracting all the musical energy from the record grooves without exciting destructive resonances requires both science and art. Let's take a closer look at each of the elements of the C 588 with an explanation of the choices we made.

ELECTRONIC SPEED CONTROL ▼

Having exact pitch (speed) is important, but human hearing is much more sensitive to momentary changes in speed which we express with the terms Wow and Flutter. As its name sounds, Wow is a slow cyclical speed variation. The most severe example is the sound of a severely warped record, where the stylus travels faster on the rising side of the warp and slower on the descending side, causing abrupt changes in musical pitch. Flutter is what we call very fast and small variations that are usually generated by the motor. The C 588 addresses both of these problems with proven and effective solutions. A specialized, high precision, synchronous clock motor is both very smooth and accurate, especially when driven from a stable AC voltage. To ensure a clean and stable AC voltage we isolate the AC Mains by first converting it to a clean DC voltage, and then electronically generating the precise AC frequency to regulate the synchronous motor. Using a specially formulated belt to drive the platter further filters and isolates any remaining vibration. All rotating parts are made from aluminum alloy machined to very tight tolerances to eliminate any eccentricity or vibration in the drive system.

TO NEARM AND CARTRIDGE ▼

The C 588 features a custom designed carbon fiber tonearm shaft with a fixed metal head shell and features a decoupled counterweight and magnetic anti-skate compensation. An Ortofon 2M Red cartridge is factory installed and offers superb tracking and a delicately nuanced full range sound. The C 588 uses a longer than usual 9" tonearm to optimize overhang and reduce the tracking angle error. To perfectly align the stylus we include adjustments for azimuth and vertical tracking angle, and include a gauge to calibrate the alignment, a rarity at this price point.

FEATURES & DETAILS

- ▶ Belt Driven Turntable 33/45
- ▶ 10mm Glass Plater with Felt Pad
- ▶ Precision Alloy Sub Platter
- ▶ Precision AC Motor
- ▶ Isolated AC Power Supply with Universal Voltage
- ▶ 9" Carbon Fibre Tonearm with Fixed Head Shell
- ▶ Ortofon 2M Red Cartridge Preinstalled
- ▶ Vertical Tracking Angle and Azimuth Adjustment
- ▶ Rigid MDF Plinth
- ▶ Metal Feet with Tuned Isolation
- ▶ Low Resonance Dustcover
- ▶ Detachable High Quality RCA Cable with separate Ground



CLOSING THE TRIANGLE▼

To fully realize the micro-dynamics of music requires a very tight mechanical coupling of the platter and the tonearm. This forms a triangle, as vibrations can travel from record being played, to the platter, through the shaft and bearing to the base (plinth), up the arm mount through the arm pivot and down the arm to the cartridge and stylus. There are many separate parts in this path and some of them are required move relative to one another through mechanical bearing interfaces. If there is any play in these mechanical interfaces musical energy will be lost. This why NAD has paid strict attention to precision machining, assembly, and testing that is so important in a turntable.

RESONANCE CONTROL AND ISOLATION▼

Reducing all spurious vibrations to a minimum is critical to getting the best result when playing vinyl. Since these vibrations can come from various sources, both internal and external, the materials and dimensions must all be carefully calculated reduce

and balance all the resonances to prevent a buildup of energy at particular frequencies. To isolate external vibrations from the loudspeakers or footfalls bouncing the floor, we use a massive MDF base with specially tuned vibration damping feet, along with a thick non-resonant dust cover. The choice of glass platter, felt pad, MDF base, and carbon fiber tonearm, were carefully considered to work together to limit and reduce spurious vibration.

RECIPE OR INGREDIENTS?▼

They say a great chef can make delicious food from very basic ingredients, while a cook without training can make a mess of even the finest and most exotic ingredients. NAD is a Five Star Chef in the audio world, designing award winning products for 45 years now. We think the C 588 hits a sweet spot for performance and value by using very simple high quality parts and precisely engineering them to work together in perfect harmony. We believe the result to be a feast for the ears that will last for years and bring new life to your existing record collection while preserving it for the future.

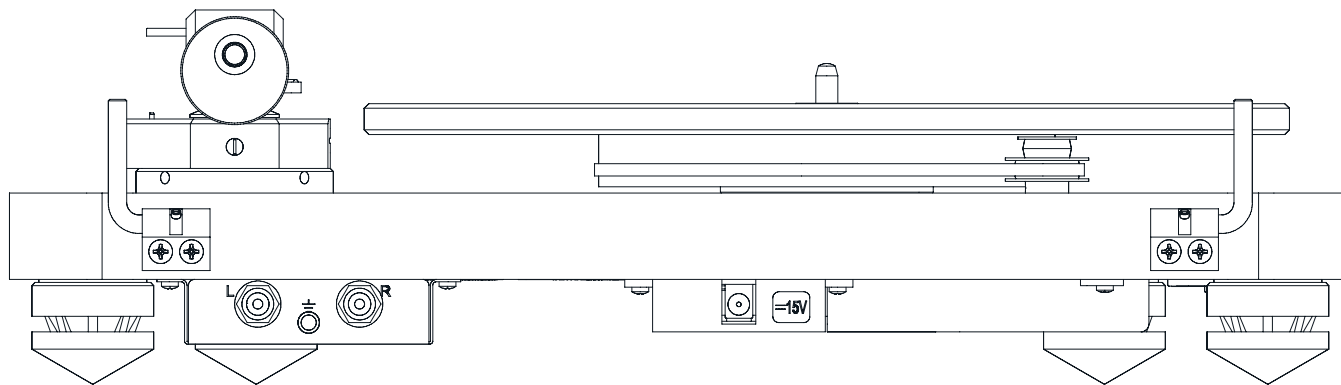

Specifications C 588 ▾

GENERAL SPECIFICATIONS	
Nominal speed	33/45 rpm, manual speed change (78 rpm possible with special pulley)
Speed variance	33 rpm: $\pm 0.35\%$, 45 rpm: $\pm 0.30\%$
Wow and flutter	33 rpm: $\pm 0.12\%$, 45 rpm: $\pm 0.11\%$
Signal to noise	- 70 dB
Downforce range	0 - 30 mN 0 - 3.0 grams
Supplied counterweight system	Counterweight for cartridges: 6 - 13 g
Voltage	Universal switch mode power supply 15 V DC/0,8 A, 100-240 V AC, 47 - 63Hz
Power consumption	5 W max/ 0.3W standby
TONEARM	
Effective tonearm mass	9.5 g
Effective tonearm length	230 mm
Overhang	18 mm
ORTOFON 2M RED CARTRIDGE	
Frequency range	20-22.000Hz
Channel separation	22dB/1kHz
Output voltage	5.5 mV
Recommended load impedance	47 kohms/Amplifier connection: MM-input
Compliance/stylus type	20 μ m/mN – elliptical
Recommended tracking force	18 mN
Weight	7.2g
DIMENSIONS AND WEIGHT	
Gross Dimensions (W x H X D)	17 1/8 x 13 7/16 x 4 15/16" (435 x 340 x 125mm)
Shipping Weight	9.2 kg(20.3 lbs)

* Gross dimensions include feet and rear panel terminals. ** Non-metric measurements are approximate. NAD Electronics will not assume any liability for errors being made by retailers, custom installers, cabinet makers, or other end users based on information contained in this document. Note: Installers should allow a minimum clearance of 55mm for wire/cable management.



NAD Electronics International reserves the right to change specifications or features without notice. NAD is a registered trademark of NAD Electronics International. All rights reserved. No part of this publication may be reproduced, stored, or transmitted in any form whatsoever without the written permission of NAD Electronics International. © 10/18 17-057 NAD Electronics International. www.NADelectronics.com