

COVE1800 BLACK

 **Furniture**

**DIGITAL
CINEMA**

**AVAILABLE AT
DIGITAL CINEMA**



Tempered
Safety Glass



Ready to be
Assembled



Max Weight
Top 50Kgs / Other 30Kgs



Cable Management
System

Model: Cove1800 Black

1800W x 550D x 500H mm

2 x Drawers

Curved Front Edge Design

Perfect for housing Sound Bars

1 Year Warranty

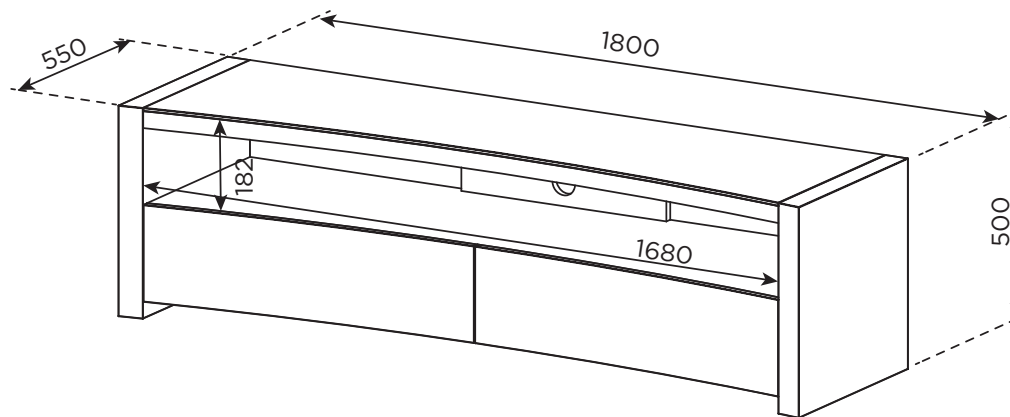

www.rvm.com.au

DISTRIBUTED BY RVM AUSTRALIA t: (08) 9417 9944 e: sales@rvm.com.au